

**COUNTY OF SAN MATEO
PLANNING AND BUILDING DEPARTMENT**

DATE: October 13, 2021

TO: Planning Commission

FROM: Planning Staff

SUBJECT: EXECUTIVE SUMMARY: Consideration of an appeal of the Community Development Director's approval of a Grading Permit, pursuant to Section 9283 of the County Grading Regulations, to allow 278 cubic yards of cut and 178 cubic yards of fill in association with the demolition of an existing single-family residence and the construction of a new 3,985 sq. ft. two-story single-family residence with an attached 446 sq. ft. garage and attached 779 sq. ft. accessory dwelling unit located on a legal 7,026 sq. ft. parcel located at 1061 Los Trancos Road in the unincorporated Los Trancos Woods area of San Mateo County. The project involves the removal of seven (7) significant trees in the footprint of the proposed home.

County File Number: PLN 2020-00356 (Awbrey)

PROPOSAL

The appealed Grading Permit allows 278 cubic yards of cut and 178 cubic yards of fill in association with the demolition of an existing single-family residence and the construction of a new 3,985.7 sq. ft. two-story single-family residence with an attached 446 sq. ft. garage and attached 779.9 sq. ft. accessory dwelling unit located on a legal 7,026 sq. ft. parcel. The project involves the removal of seven (7) significant trees in the footprint of the proposed home, which includes three valley oak trees (16.3" - 20" DBH), one redwood tree (16" DBH), and three bay trees (14" - 18" DBH). The project is located at 1061 Los Trancos Road in the unincorporated Los Trancos Woods area. The primary concerns of the appeal relate to potential drainage impacts to neighboring properties that could result from the proposed development, please see Section B of the staff report for further discussion.

RECOMMENDATION

That the Planning Commission deny the appeal and uphold the decision of the Community Development Director to approve the Grading Permit, County File Number PLN 2020-00356, by making the findings and adopting the conditions of approval contained in Attachment A.

SUMMARY

The following discussion summarizes the major points of the appeal followed by Staff's response:

1. Appellant: *The amount of impervious surface on the sloped property is not acceptable. The cut for the large footprint of the home on this slope does not have an adequate plan for capturing stormwater runoff and dissipating it given the large amount of impervious surface. The concentration of the water to the rear of the property will quickly overwhelm the pit and saturate the soil leading to concerns of flooding in the basement of the appellant's property.*

Staff's Response: The proposed home complies with all zoning development standards. The County's Drainage Policy requires post-development runoff and velocity to be equal to, or less than, pre-development runoff and velocity and that no additional runoff, caused by development, can cross property lines. In response to the concerns raised by the appeal, and after further review of the proposed project construction and geotechnical documents, a condition of approval has been added (Condition 20) that requires modifications to the proposed drainage system, so that runoff from all new and replaced impervious surface onsite will be appropriately detained and metered to dissipation devices that will prevent impacts to neighboring properties and the watershed. Additionally, the existing septic system on site will be removed and the property will be connected to municipal sewer, removing an additional source of moisture to the soil.

2. Appellant: *None of the plans show significant trees on adjacent properties. There are significant trees along/near the proposed retaining wall and its pilings that could potentially harm trees in this area.*

Staff's Response: The applicant has submitted an extensive arborist report that documents the health of trees and protection measures for the trees in the area of construction. The arborist report, tree removal and protection plans, and proposed tree replacement have been reviewed and approved by the County Arborist. An additional condition of approval (Condition 6) is included in the staff recommendation that requires an update to the arborist report to show all portions of the tree canopy that overhang into the subject property, and to include measures to prevent impact to the canopy during construction.

3. Appellant: *The septic drain fields from a neighboring parcel at 1035 Los Trancos Road ends 5 feet from the property line in the vicinity of a proposed drywell on the subject property. The drywell is too small and will cause surface flooding issues that could impact the septic drain fields; the*

appellant asks that the option of pumping the stormwater to the street be considered.

Staff's Response: County drainage policy is that natural drainage patterns be preserved wherever feasible; rather than pumping the stormwater to the street, the project is required to install a retention and metering system that will slow any runoff from the project and dissipate it over time. The drywell and associated deeper infiltration measures will be removed from the proposed plan, and the metered surface flows are not anticipated to have significant impacts on the neighboring properties as it will be mimicking natural, pre-development drainage patterns. Environmental health imposes a strict 25-foot setback for infiltration features from leach lines of septic systems.

4. Appellant: *The engineers expressed that large fills are generally not desirable on slopes and the Geotechnical Department has concerns regarding the development plan and water issues.*

Staff's Response: The applicant will address all geotechnical and drainage review comments. The comments the appellant is referring to were dated December 30, 2020 from the County's Drainage Section which cited issues with the drainage plan. After further review, this drainage plan has been conditioned (condition 20) to be consistent with the Geotechnical Engineer's recommendations while still complying with County drainage policy.

KAK:cmc – KAKFF0835_WCU.DOCX

**COUNTY OF SAN MATEO
PLANNING AND BUILDING DEPARTMENT**

DATE: October 13, 2021

TO: Planning Commission

FROM: Planning Staff

SUBJECT: Consideration of an appeal of the Community Development Director's approval of a Grading Permit, pursuant to Section 9283 of the County Grading Regulations, to allow 278 cubic yards of cut and 178 cubic yards of fill in association with the demolition of an existing single-family residence and the construction of a new 3,985 sq. ft. two-story single-family residence with an attached 446 sq. ft. garage and attached 779 sq. ft. accessory dwelling unit located on a legal 7,026 sq. ft. parcel located at 1061 Los Trancos Road in the unincorporated Los Trancos Woods area of San Mateo County. The project involves the removal of seven (7) significant trees in the footprint of the proposed home.

County File Number: PLN 2020-00356 (Awbrey)

PROPOSAL

The appealed Grading Permit allows 278 cubic yards of cut and 178 cubic yards of fill in association with the demolition of an existing single-family residence and the construction of a new 3,985.7 sq. ft. two-story single-family residence with an attached 446 sq. ft. garage and attached 779.9 sq. ft. accessory dwelling unit located on a legal 7,026 sq. ft. parcel. The project involves the removal of seven (7) significant trees in the footprint of the proposed home, which includes three valley oak trees (16.3" - 20" DBH), one redwood tree (16" DBH), and three bay trees (14"- 18" DBH). The project is located at 1061 Los Trancos Road in the unincorporated Los Trancos Woods area. The primary concerns of the appeal relate to potential drainage impacts to neighboring properties as a result of the proposed development, see Section B of the staff report for further discussion.

RECOMMENDATION

That the Planning Commission deny the appeal and uphold the decision of the Community Development Director to approve the Grading Permit, County File Number PLN 2020-00356, by making the findings and adopting the conditions of approval contained in Attachment A.

BACKGROUND

Report Prepared By: Kanoa Kelley, Project Planner, kkelley@smcgov.org

Applicant/Owner: Craig Awbrey/Awbrey Development Company Inc.

Appellant: Chad Sefcik

APN: 080-084-320

Location: 1061 Los Trancos Road, Portola Valley (Attachment B – Vicinity Map)

Lot Size: 7,026 sq. ft.

Existing Zoning: R-1/S-83 (Single-Family Residential District/S-83 Combining District)

General Plan Designation: Low Density Residential (0.3-2.3 dwelling units/acre)

Sphere-of-Influence: Town of Portola Valley

Existing Land Use: Single-family residence

Water Supply: California Water Service – Bear Gulch

Sewage Disposal: Existing private onsite septic disposal system. The property has been annexed into West Bay Sanitary District who will serve the proposed development.

Flood Zone: The project site is located in Flood Zone X (area of minimal flood hazard, usually depicted on FIRMs as above the 500-year flood level), per FEMA Panel No. 06081C0402E, effective October 16, 2012.

Parcel Legality: The parcel's legality was established through a Certificate of Compliance Type A, PLN2019-00466, recorded on December 17, 2019.

Environmental Evaluation: Categorically exempt pursuant to Section 15303, Class 3(a), of the California Environmental Quality Act (CEQA) Guidelines, related to new construction of small structures, including single-family residences in a residential zone.

Setting: The project site is a previously developed parcel off of Los Trancos Road between Ramona Road and Foxwood Road. The site is heavily vegetated with trees.

Chronology:

<u>Date</u>	<u>Action</u>
October 20, 2020	- Application submitted.
June 18, 2021	- Application deemed complete and Grading Permit approval issued.
June 28, 2021	- In accordance with Section 9291 of the Grading Ordinance, an appeal of the Grading Permit was submitted by Chad Sefcik within 10 working days of the approval.
October 13, 2021	- Planning Commission public hearing.

DISCUSSION

A. KEY ISSUES

1. COMMUNITY DEVELOPMENT DIRECTOR ACTION

The Community Development Director approved the Grading Permit on June 18, 2021 based on the following findings:

- a. The granting of this permit will have no significant adverse effect on the environment. This project has been reviewed and approved by the Department of Public Works and the Building Inspection Geotechnical and Drainage Sections. With implementation of the proposed Grading Plan and Condition of Approval No. 20, which requires the project engineer provide written certification that all grading has been completed in conformance with the approved plans, Grading Regulations, and conditions of approval, the potential for impacts related to geologic conditions is minimized to a less than significant level. Similarly, implementation of the approved Erosion Control Plan and Tree Protection Plan will protect on site and neighboring trees and minimize the potential for significant erosion on site.
- b. The project conforms to the criteria of Chapter 5, Division VII, San Mateo County Ordinance Code, including the standards referenced in Section 9296. Planning staff, the Geotechnical Section, Department of Public Works, and the Building Department's Drainage Section have reviewed the project and have determined the project as proposed and conditioned conforms to the criteria of Chapter 5, Division VII, San Mateo County Ordinance Code, including timing of grading activity, implementation of erosion and sediment control measures, and dust control measures.

- c. The project is consistent with the General Plan. The subject site has a General Plan land use designation of Low Density Residential. The proposed project is consistent with the allowed density and land use designation. As proposed and conditioned, the project complies with General Plan Policy 2.17 (*Regulate Development to Minimize Soil Erosion and Sedimentation*) and Policy 2.23 (*Regulate Excavation, Grading, Filling, and Land Clearing Activities Against Accelerated Soil Erosion*) as the project includes measures and conditions to control and address each of these items.

B. APPEAL OF THE COMMUNITY DEVELOPMENT DIRECTOR'S APPROVAL

On June 28, 2021, Planning staff received an appeal application filed by Chad Sefcik, property owner of 1033 Los Trancos Road (an adjacent parcel to the east of the project site), appealing the Community Development Director's approval of the Grading Permit (Attachment G – Appeal Application).

The following discussion summarizes the major points of the appeal followed by staff's response:

1. Appellant: *The amount of impervious surface on the sloped property is not acceptable. The cut for the large footprint of the home on this slope does not have an adequate plan for capturing stormwater runoff and dissipating it given the large amount of impervious surface. The concentration of the water to the rear of the property will quickly overwhelm the pit and saturate the soil leading to concerns of flooding in the basement of the appellant's property.*

Staff's Response: The proposed home complies with all zoning development standards. The County's Drainage Policy requires post-development runoff and velocity to be equal to, or less than, pre-development runoff and velocity and that no additional runoff, caused by development, can cross property lines. In response to the concerns raised by the appeal, and after further review of the proposed construction and geotechnical documents, a condition of approval has been added (Condition 20) that requires modifications to the proposed drainage system, so that runoff from all new and replaced impervious surface onsite will be appropriately detained and metered to dissipation devices that will avoid impacts to neighboring properties and the watershed. Additionally, the existing septic system on site will be removed and the property will be connected to municipal sewer, removing an additional source of moisture to the soil.

2. Appellant: *None of the plans show significant trees on adjacent properties. There are significant trees along/near the proposed retaining wall and its pilings that could potentially harm trees in this area.*

Staff's Response: The applicant has submitted an extensive arborist report that documents the health of trees and protection measures for the trees in the area of construction. The arborist report, tree removal and protection plans, and proposed tree replacement have been reviewed and approved by the County Arborist. An additional condition of approval (Condition 6) is included in the staff recommendation that requires an update to the arborist report to show all portions of the tree canopy that overhang into the subject property, and to include measures to prevent impact to the canopy during construction.

3. Appellant: *The septic drain fields from a neighboring parcel at 1035 Los Trancos Road ends 5 feet from the property line in the vicinity of a proposed drywell on the subject property. The drywell is too small and will cause surface flooding issues that could impact the septic drain fields; the appellant asks that the option of pumping the stormwater to the street be considered.*

Staff's Response: County drainage policy is that natural drainage patterns be preserved wherever feasible; rather than pumping the stormwater to the street, the project is required to install a retention and metering system that will slow any runoff from the project and dissipate it over time. The drywell and associated deeper infiltration measures will be removed from the proposed plan, and the metered surface flows are not anticipated to have significant impacts on the neighboring properties as it will be mimicking natural, pre-development drainage patterns. Environmental health imposes a strict 25-foot setback for infiltration features from leach lines of septic systems.

4. Appellant: *The engineers expressed that large fills are generally not desirable on slopes and the Geotechnical Department has concerns regarding the development plan and water issues.*

Staff's Response: The applicant will address all geotechnical and drainage review comments. The comments the appellant is referring to were dated December 30, 2020 from the County's Drainage Section which cited issues with the drainage plan. After further review, this drainage plan has been conditioned (condition 20) to be consistent with the Geotechnical Engineer's recommendations while still complying with County drainage policy.

C. ANALYSIS OF PROJECT COMPLIANCE WITH APPLICABLE COUNTY POLICIES AND REGULATIONS

1. Conformance with the County General Plan

Upon review of the applicable provisions of the General Plan, staff has determined that the project complies with all General Plan Policies, including the following:

Vegetative, Water, Fish and Wildlife Resources Policies

Policy 1.24 (*Regulate Location, Density and Design of Development to Protect Vegetative, Water, Fish and Wildlife Resources*) calls for the regulation of development to minimize significant adverse impacts and encourage enhancement of vegetative, water, fish and wildlife resources. The subject parcel is located in a wooded area off of Los Trancos Road. The project includes the removal of 7 significant trees which consist of three valley oak trees (16.3" - 20" DBH), one redwood tree (16" DBH), and three bay trees (14" - 18" DBH). The trees proposed for removal are the minimum necessary to accommodate the proposed development as these trees are within the footprint of the proposed development. Due to the existing dense tree canopy, a typical 1 to 1 replacement was not recommended by the County Arborist to maintain the health of existing trees. Therefore, one oak tree, minimum 15-gallon size stock, is required to be replanted on site. An arborist report was submitted with the application. The arborist report describes the health of the 16 trees surrounding the development along with tree protection recommendations that will be implemented as part of the tree protection plan. Additionally, a condition has been added to require an arborist report to document the health of existing trees post construction. If any trees are damaged or effectively removed during construction, additional tree replacement may be required.

Review of the California Natural Diversity Database shows no special-status plant or animal species identified on the project site or within the immediate vicinity of the project site.

Soil Resources

Policy 2.17 (*Regulate Development to Minimize Soil Erosion and Sedimentation*) and Policy 2.23 (*Regulate Excavation, Grading, Filling, and Land Clearing Activities Against Accelerated Soil Erosion*) call for the regulation of development to minimize soil erosion and sedimentation. The project involves 456 cubic yards of grading, including 278 cubic yards of cut and 178 cubic yards of fill. There is a potential for erosion to occur if proper erosion control measures are not implemented. The applicant has developed an erosion control plan that includes straw wattles around the perimeter of the construction area, sediment traps and basins, storm drain inlet protection and a stabilized construction entrance. Implementation of the erosion and sediment control plan and conditions of approval to ensure

appropriate timing of grading work will ensure erosion and sediment impacts are minimized.

Water Supply

Policy 10.1 (*Coordinate Planning*) requires the County to coordinate water supply planning with land use and wastewater management planning to assure that the supply and quality of water is commensurate with the level of development planned in the area. California Water Service has confirmed that a water service connection is available for the project site.

Wastewater Policies

Policies 11.1 and 11.2 (*Adequate Wastewater Management and Coordinate Planning*) require the County to plan for the provision of adequate wastewater management facilities to serve development in order to protect public health and water quality and to coordinate wastewater management planning with land use and water supply planning to assure that the capacity of sewerage facilities is commensurate with the level of development planned for an area. Existing development on the parcel is served by a private onsite septic disposal system which will be removed. The proposed development will be served by public sewer; the parcel has been annexed into West Bay Sanitary District which has confirmed adequate capacity to serve the parcel.

2. Conformance with the Zoning Regulations

a. Conformance with S-83 District Development Standards

The preliminary development proposal complies with the property’s R-1/S-83 Zoning provisions, as indicated in the following table:

	S-83 Development Standards	Proposed
Minimum Site Area	7,500 sq. ft.	7,026 sq. ft. (existing legal parcel)
Maximum Floor Area (includes garage)	3,200 sq. ft.	3,200 sq. ft.
Maximum Building Site Coverage	40% (2,810.4 sq. ft.)	30% (2,149.1 sq. ft.)
Minimum Front Setback	20 ft.	26 ft.

	S-83 Development Standards	Proposed
Minimum Rear Setback	20 ft.	27 ft.
Minimum Right Side Setback	5 ft.	5.34 ft.
Minimum Left Side Setback	5 ft.	5 ft.
Maximum Building Height	36 ft. (3 stories)	36 ft. (3 stories)
Minimum Parking Spaces	2	2 (enclosed)

D. ENVIRONMENTAL REVIEW

This project is exempt from environmental review pursuant to the California Environmental Quality Act (CEQA) Guidelines, Section 15303, Class 3(a), related to new construction of small structures, including single-family residences in a residential zone.

E. REVIEWING AGENCIES

Building Inspection Section
 Department of Public Works
 Drainage Section
 Geotechnical Section
 Woodside Fire Protection District
 West Bay Sanitary District
 California Water Service- Bear Gulch

ATTACHMENTS

- A. Recommended Findings and Conditions of Approval
- B. Vicinity Map
- C. Project Plans
- D. Arborist Report
- E. Geotechnical Report
- F. Grading Permit Approval, dated June 18, 2021
- G. Appeal Application

KAK:cmc – KAKFF0836_WCU.DOCX

County of San Mateo
Planning and Building Department

RECOMMENDED FINDINGS AND CONDITIONS OF APPROVAL

Permit or Project File Number: PLN 2020-00356 Hearing Date: October 13, 2021

Prepared By: Kanoa Kelley For Adoption By: Planning Commission
Project Planner

RECOMMENDED FINDINGS

The Planning Commission finds that:

For the Environmental Review

1. The project is exempt from environmental review pursuant to the California Environmental Quality Act (CEQA) Guidelines, Section 15303, Class 3, related to the construction of a single-family residence in a residential zone.

For the Tree Removal

2. The required action is necessary to allow reasonable economic enjoyment of the property.
3. The trees will be replaced by plantings approved by the Community Development Director, or designee.

For the Grading Permit

4. The granting of this permit will have no significant adverse effect on the environment. This project has been reviewed and approved by the Department of Public Works and the Building Inspection Geotechnical and Drainage Sections. With implementation of the proposed Grading Plan and Condition of Approval No. 12, which requires the project engineer provide written certification that all grading has been completed in conformance with the approved plans, Grading Regulations, and conditions of approval, the potential for impacts related to geologic conditions is minimized to a less than significant level. Similarly, implementation of the approved Erosion Control Plan and Tree Protection Plan will protect on site and neighboring trees and minimize the potential for significant erosion on site.
5. The project conforms to the criteria of Chapter 5, Division VII, San Mateo County Ordinance Code, including the standards referenced in Section 9296. Planning staff, the Geotechnical Section, Department of Public Works, and the Building Department's Drainage Section have reviewed the project and have determined the project as proposed and conditioned conforms to the criteria of Chapter 5, Division VII, San Mateo County Ordinance Code, including timing of grading activity,

implementation of erosion and sediment control measures, and dust control measures.

6. The project is consistent with the General Plan. The subject site has a General Plan land use designation of Low Density Residential. The proposed project is consistent with the allowed density and land use designation. As proposed and conditioned, the project complies with General Plan Policy 2.17 (*Regulate Development to Minimize Soil Erosion and Sedimentation*) and Policy 2.23 (*Regulate Excavation, Grading, Filling, and Land Clearing Activities Against Accelerated Soil Erosion*) as the project includes measures and conditions to control and address each of these items.

CONDITIONS OF APPROVAL

Current Planning Section

1. This approval applies only to the proposal as described in the latest plans, supporting materials, and reports submitted as of the date of this letter. Minor revisions or modifications to the project may be made subject to the review and approval of the Community Development Director, if they are consistent with the intent of, and in substantial conformance with, this approval.
2. The grading permit shall be valid for one (1) year from the date of final approval, in which time a building permit shall be issued and a completed inspection (to the satisfaction of the Building Inspection Section) shall have occurred within 365 days of its issuance. The Grading Permit (issued as the "hard card" with all necessary information filed out and signatures obtained) shall only be issued concurrently with the building permit for the new single-family residence. No grading activities shall commence until all permits have been issued. Approval of permits may be extended by a 1-year increment upon written request and payment of applicable extension fees 60 days prior to expiration.
3. No grading shall be allowed during the winter season (October 1 to April 30) or during any rain event to avoid potential soil erosion unless approved, in writing, by the Community Development Director. The applicant shall submit an Exception to the Winter Grading Moratorium application along with a winterization plan to the Current Planning Section at least two weeks prior to the projected commencement of grading activities stating the date when grading will begin for consideration for an exemption to the Winter Grading Moratorium.
4. This permit allows for the removal of seven (7) significant trees as shown on the approved plans. Removal of any additional trees with a diameter greater than 12 inches (as measured 4.5 feet above the ground) shall require a separate tree removal permit application and payment of applicable fees.
5. One oak tree using a minimum 15-gallon stock shall be planted for the trees removed. All proposed replacement trees shall be shown on a Tree Replanting Plan or Landscape Plan and shall include species, size and location. The Plan shall be submitted to the County Planning and Building Department for review and approval as part of the building permit plan sets.

6. The arborist report shall be updated to identify all portions of the tree canopy that overhang into the subject property, and to include measures to prevent impact to the canopy during construction. A subsequent arborist report shall be submitted prior to final inspection documenting the health of the existing trees post construction. If any of the trees have been damaged by construction such that they are considered “effectively removed” pursuant to Section 12,091.1 of the Significant Tree Ordinance, an after-the-fact tree removal application and payment of applicable fees shall be required and processed prior to final building inspection.
7. The provision of the San Mateo County Grading Ordinance shall govern all grading on and adjacent to this site. Per San Mateo County Ordinance Section 9296.5, all equipment used in grading operations shall meet spark arrester and firefighting tool requirements, as specified in the California Public Resources Code.
8. The engineer who prepared the approved grading plan shall be responsible for the inspection and certification of the grading as required by Section 9297.2 of the Grading Ordinance. The engineer’s responsibilities shall include those relating to non-compliance detailed in Section 9297.4 of the Grading Ordinance.
9. Prior to the beginning of all construction, the applicant shall implement the approved erosion and sediment control plan and tree protection plan, which shall be maintained throughout the duration of the project. The goal is to prevent significant trees, as defined by San Mateo County’s Significant Tree Ordinance, Section 12,000, from injury or damage related to construction activities, prevent sediment and other pollutants from leaving the project site and to protect all exposed earth surfaces from erosive forces. Said plan shall adhere to the San Mateo County Wide Stormwater Pollution Prevention Program “General Construction and Site Supervision Guidelines,” including:
 - a. Stabilizing all denuded areas and maintaining erosion control measures continuously between October 1 and April 30. Stabilizing shall include both proactive measures, such as the placement of hay bales or coir netting, and the use passive measures, such as revegetating disturbed areas with plants propagated from seed collected in the immediate area.
 - b. Storing, handling, and disposing of construction materials and wastes properly, so as to prevent their contact with stormwater.
 - c. Controlling and preventing the discharge of all potential pollutants, including pavement cutting wastes, paints, concrete, petroleum products, chemicals, wash water or sediments, and non-stormwater discharges to storm drains and watercourses.
 - d. Using sediment controls or filtration to remove sediment when dewatering site and obtain all necessary permits.
 - e. Avoiding cleaning, fueling, or maintaining vehicles on-site, except in a designated area where wash water is contained and treated.
 - f. Delineating with field markers clearing limits, easements, setbacks, sensitive or critical areas, buffer zones, trees, and drainage courses.

- g. Protecting adjacent properties and undisturbed areas from construction impacts using vegetative buffer strips, sediment barriers or filters, dikes, mulching, or other measures as appropriate.
 - h. Performing clearing and earth moving activities only during dry weather.
 - i. Limiting and timing application of pesticides and fertilizers to prevent polluted runoff.
 - j. Limiting construction access routes and stabilize designated access points.
 - k. Avoiding tracking dirt or other materials off-site; clean off-site paved areas and sidewalks using dry sweeping methods.
 - l. The contractor shall train and provide instruction to all employees and subcontractors regarding the construction Best Management Practices.
 - m. The approved erosion and sediment control plan shall be implemented prior to the beginning of construction.
 - n. Failure to install or maintain these measures will result in stoppage of construction until the corrections have been made and fees paid for staff enforcement time.
10. All grading and erosion and sediment control measures shall be in accordance to the plans prepared by Vit Hanacek Engineering, dated October 14, 2020, and approved by the Department of Public Works, Geotechnical Section, and the Current Planning Section. Revisions to the approved grading plan shall be prepared and signed by the engineer and shall be submitted to the Building Inspection Section and the Current Planning Section concurrently prior to commencing any work pursuant to the proposed revision.
11. It shall be the responsibility of the applicant's engineer to regularly inspect the erosion control measures and determine that they are functioning as designed and that proper maintenance is being performed. Deficiencies shall be immediately corrected.
12. For the final approval of the Grading Permit, the applicant shall ensure the performance of the following activities within thirty (30) days of the completion of grading:
- a. The engineer shall submit written certification to the Department of Public Works and the Geotechnical Section that all grading has been completed in conformance with the approved plans, conditions of approval, and the Grading Ordinance.
 - b. All applicable work during construction shall be subject to observation and approval by the geotechnical consultant. Section II of the Geotechnical Consultant Approval form must be submitted to the County's Geotechnical Engineer and Current Planning Section.

13. Noise sources associated with demolition, construction, repair, remodeling, or grading of any real property shall be limited to the hours from 7:00 a.m. to 6:00 p.m. weekdays and 9:00 a.m. to 5:00 p.m. Saturdays. Said activities are prohibited on Sundays, Thanksgiving and Christmas (San Mateo County Ordinance Code Section 4.88.360).
14. An Erosion Control and/or Tree Protection Pre-site Inspection is required prior to the issuance of a building permit for construction and demolition to ensure the approved erosion control and tree protection measures are installed adequately prior to the start of ground disturbing activities. Once all review agencies have approved your building permit, you will be issued an approved job copy of the Erosion Control and/or Tree Protection Plan. Once the Erosion Control and/or Tree Protection measures have been installed per the approved plans, please contact the project planner of record to schedule a pre-site inspection. A \$144 inspection fee will be assessed to the building permit for the inspection. If the initial pre-site inspection is not approved, an additional inspection fee will be assessed for each required re-inspection until the job site passes the Pre-Site Inspection.
15. To reduce the impact of construction activities on neighboring properties, comply with the following:
 - a. All debris shall be contained on-site; a dumpster or trash bin shall be provided on site during construction to prevent debris from blowing onto adjacent properties. The applicant shall monitor the site to ensure that trash is picked up and appropriately disposed of daily.
 - b. The applicant shall remove all construction equipment from the site upon completion of the use and/or need of each piece of equipment which shall include but not be limited to tractors, back hoes, cement mixers, etc.
 - c. The applicant shall ensure that no construction-related vehicles shall impede through traffic along the right-of-way on Los Trancos Road. All construction vehicles shall be parked on-site outside the public right-of-way or in locations which do not impede safe access on Los Trancos Road. There shall be no storage of construction vehicles in the public right-of-way.
16. The site is considered a Construction Stormwater Regulated Site (SWRS). Any grading activities conducted during the wet weather season (October 1 to April 30) will require monthly erosion and sediment control inspections by the Building Inspection Section, as well as prior authorization from the Community Development Director to conduct grading during the wet weather season.

Building Inspection Section

17. A building permit is required.

Geotechnical Section

18. The Project Geotechnical Consultant should utilize the current LiDAR information to further examine and consider the prominent land sliding features, and incorporate into

the grading and foundation designs, and land stabilization if any, during the Building Permit application stage.

19. A Geotechnical Report shall be submitted at the Building Permit stage, the report shall be updated to the current adopted code (if 2021 -> CBC2019). Significant grading profiles, grading proposals, foundation design recommendations, retaining wall design recommendations, and basement design recommendations, if any, shall be provided in the geotechnical report at Building Stage. For a vacant site, the Geotechnical Report shall provide sufficient soil investigation data to evaluate the potential hazards, for example, expansive soils, soil corrosivity, weak soil strength, and liquefaction. If any hazards are found, mitigation shall be provided in foundation design and grading proposal.

Drainage Section

20. A revised drainage plan prepared by a qualified engineer, consisting of a retention and metering system shall be included in the plans submitted with the building permit application. The drainage system shall collect and retain the amount of stormwater that will flow off of all new and replaced impervious surfaces during a 10 year 1 hour design storm using NOAA Atlas 14 rainfall intensity specific to the site location. The collected storm water shall be metered out to a sump pump, and then to a level spreader/dissipation trench as recommended by the Geotechnical Engineer located an appropriate distance from all property lines. The drainage system design and all calculations shall be submitted to the building department drainage section for review and approval prior to the issuance of a building permit.

Department of Public Works

21. The project shall comply with the San Mateo County Drainage Policy and the San Mateo Countywide National Pollution Discharge Elimination System (NPDES) permit. Prior to the issuance of the Building permit, the applicant shall submit a plan with construction details conforming with County standards, and a drainage analysis including narrative and calculations showing pre-development and post-development runoff onto and off of the parcel demonstrating compliance with the Policy for review and approval by the Department of Public Works.
22. Prior to the issuance of the Building Permit, the applicant shall submit a driveway "Plan and Profile," to the Department of Public Works, showing the driveway access to the parcel (garage slab) complying with County standards for driveway slopes (not to exceed 20%) and to County standards for driveways (at the property line) being the same elevation as the center of the access roadway. When appropriate, as determined by the Department of Public Works, this plan and profile shall be prepared from elevations and alignment shown on the roadway improvement plans. The driveway plan shall also include and show specific provisions and details for both the existing and the proposed drainage patterns and drainage facilities.
23. No proposed construction work within the County right-of-way shall begin until County requirements for the issuance of an encroachment permit, including review of the plans, have been met and an encroachment permit issued. The applicant shall contact a Department of Public Works Inspector 48 hours prior to commencing work in the right-of-way.

24. Prior to the issuance of the Building Permit, the applicant will be required to provide payment of "roadway mitigation fees" based on the square footage (assessable space) of the proposed building per Ordinance #3277.

Woodside Fire Protection District

25. At the start of construction, a 2' x 3' address sign shall be posted in front of project site.
26. At the time of final inspection, the permanent address shall be mounted and clearly visible from the street with a minimum of 4" numbers on contrasting background.
27. One hundred (100) feet of defensible space shall be provided for the structure prior to the start of construction.
28. Upon final inspection thirty (30) feet perimeter property line defensible space shall be provided per Woodside Fire Protection District (WFPD) ordinance section 304.1.2.A
29. Approved spark arrestors will be required on all installed chimneys including outside fireplaces.
30. The applicant shall install Smoke and Carbon Dioxide detectors per 2019 CBC.
31. NFPA 13D Fire Sprinkler System shall be installed. Sprinkler plans/calculations shall be submitted separately to WFPD. The Owner/Contractor is responsible for getting the correct water flow data and that Cal-Water requires a backflow device that can decrease the water flow pressure by 12-15 PSI due to friction loss of the backflow device.
32. The driveway as proposed meets WFPD standards. If driveway dimensions are revised during construction, it must maintain compliance with WFPD standards.
33. The minimum fire flow shall be 1,000 GPM. A water supply for fire protection shall mean a fire hydrant within 600' from the building, capable of the required flow. Distance from the hydrant to the structure shall be measured via an approved roadway in which the engine can safely drive from the fire hydrant to the front door of the structure.
34. There is a fire hydrant within 600' of the property, a fire water flow test will need to be completed. Provide water flow information from Cal Water during the building permit phase.

West Bay Sanitary District (WBSD)

35. To complete annexation, the applicant shall submit a WBSD annexation application to the District office.
36. A Class 1 Permit fee is required. Connection & Reimbursement fees will be due for the Single-family Residence and Accessory Dwelling Unit.

California Water Service – Bear Gulch

37. Any improvements to the water system will be at the owner's expense, including additional services or fire protection needs.
38. All storm and sewer lines must have separation from water of 10-foot horizontal separation and 1-foot vertical separation below the water main or service line, and service lines which go thru one property to another property must have legal easements granted with documentation submitted to Cal Water before installation.
39. Cal Water's Backflow Specialist must be contacted for a site review to determine what back flow requirements are required and the placement of the assemblies.

KAK:cmc – KAKFF0836_WCU.DOCX



County of San Mateo - Planning and Building Department

ATTACHMENT B

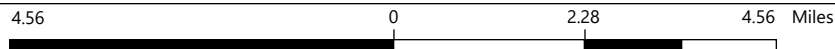
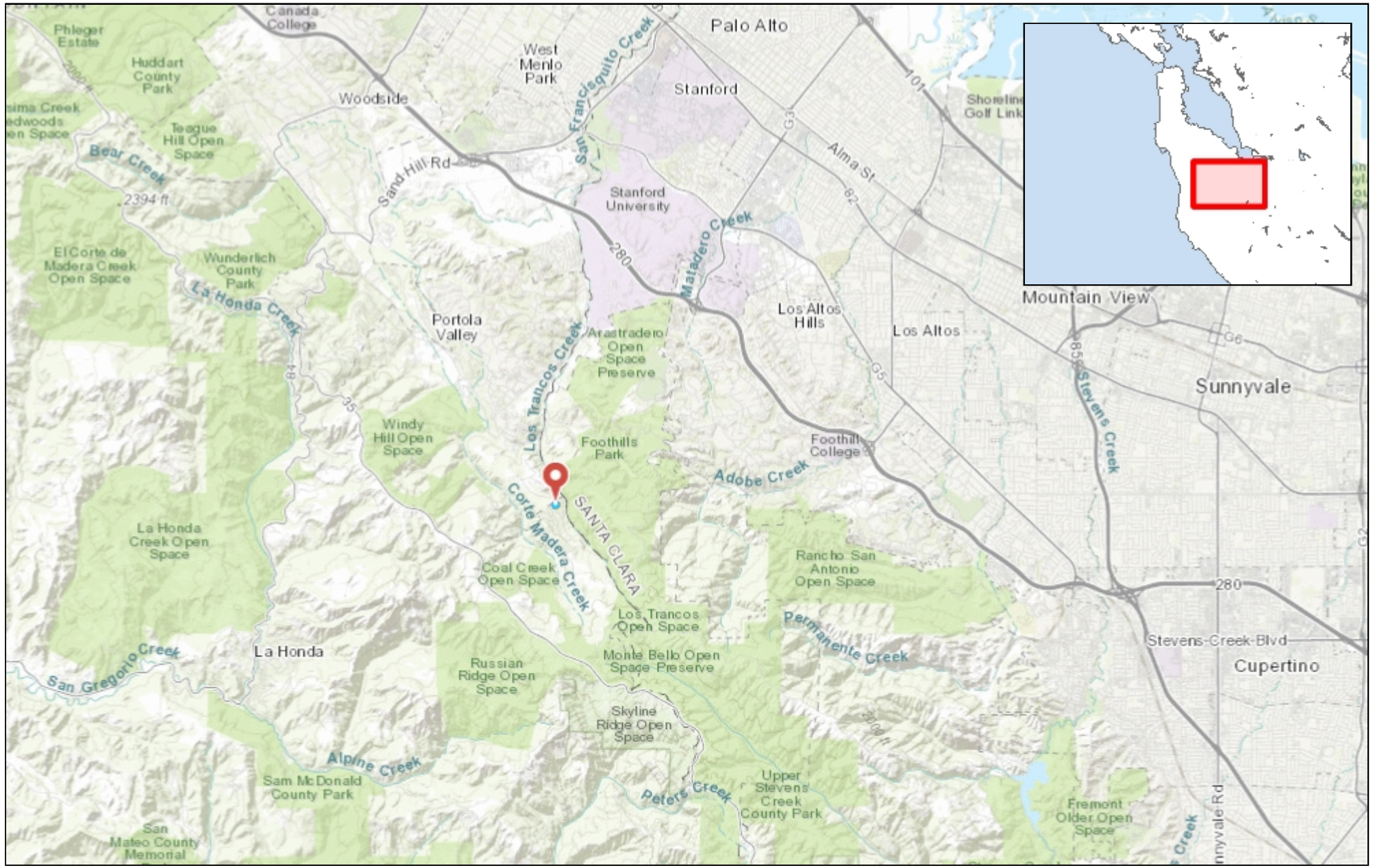

WGS_1984_Web_Mercator_Auxiliary_Sphere
 © Latitude Geographics Group Ltd.

1: 144,448

This map is a user generated static output from an Internet mapping site and is for reference only. Data layers that appear on this map may or may not be accurate, current, or otherwise reliable.

THIS MAP IS NOT TO BE USED FOR NAVIGATION



NO DATA ASSIGNED

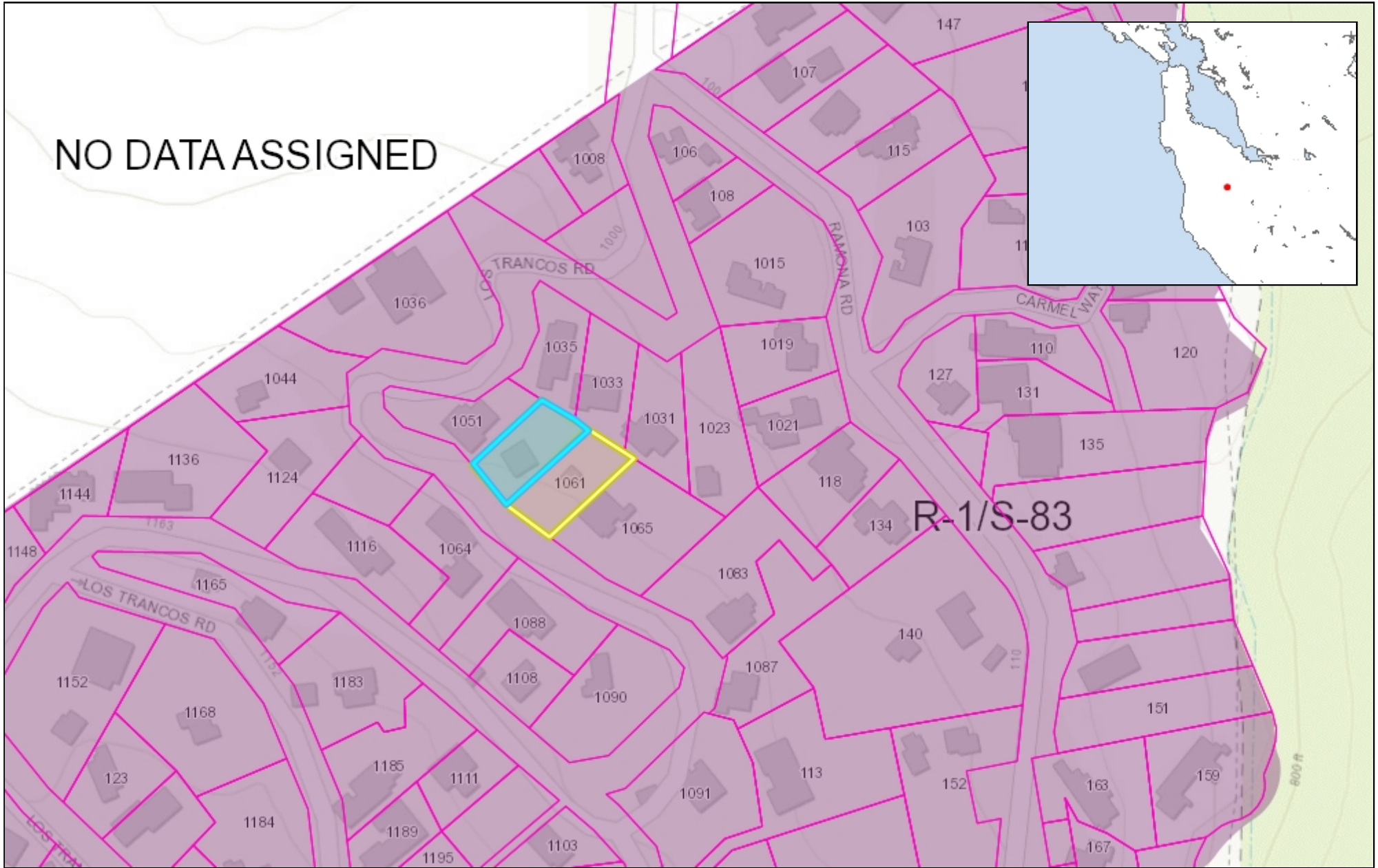

0.07 0 0.04 0.07 Miles

WGS_1984_Web_Mercator_Auxiliary_Sphere
© Latitude Geographics Group Ltd.

1:2,257

This map is a user generated static output from an Internet mapping site and is for reference only. Data layers that appear on this map may or may not be accurate, current, or otherwise reliable.

THIS MAP IS NOT TO BE USED FOR NAVIGATION



0.04 0 0.02 0.04 Miles

WGS_1984_Web_Mercator_Auxiliary_Sphere
© Latitude Geographics Group Ltd.

1:1,128 

This map is a user generated static output from an Internet mapping site and is for reference only. Data layers that appear on this map may or may not be accurate, current, or otherwise reliable.

THIS MAP IS NOT TO BE USED FOR NAVIGATION



County of San Mateo - Planning and Building Department

ATTACHMENT C



478 MONTEREY ROAD
PACIFICA, CA 94044
415.587.2004
www.beausoleil-architects.com

Submital:

OWNER REVIEW	6.1.20
GRADING/TREE PERM.	10.14.20
TO STRUCT. ENG.	10.28.20
PLANNING REVIEW	6.17.21

New Residence
1061 Los Trancos
Lot 45
Portola Valley, CA

These Documents are a "builder's set" intended for use by a qualified, experienced general contractor using qualified, experienced subcontractors and suppliers. Details, materials, systems, and methods not specified herein are fully the responsibility of the General Contractor, his subcontractors, and installers.

Sheet Title
**SITE PLAN,
ROOF PLAN**

Scale AS NOTED
Project No. 1908
Drawn By CB/RB

A1

LEVEL / AREA	AREA PER PLANNING (1)	AREA PER TYPICAL PRACTICE (2)
A.D.U.	718.1 S.F.	719.9 S.F.
BASEMENT	264.2 S.F.	488.7 S.F.
1ST FLOOR - HABITABLE	1,611.8 SF	1,702.8 SF
1ST FLOOR - GARAGE	416.3 S.F.	446.3 S.F.
2ND FLOOR	1,171.7 S.F.	1,294.2 S.F.
TOTALS	4,782.1 S.F.	5,211.9 S.F.

(1) MEASURED TO INSIDE FACE OF EXTERIOR WALLS, CENTERLINE OF DEMISING WALLS, OPENINGS IN FLOORS NOT COUNTED

(2) MEASURED TO OUTSIDE FACE OF EXTERIOR WALLS, CENTERLINE OF DEMISING WALLS, OPENINGS IN FLOORS NOT COUNTED

3 Floor Area Tabulations

1/4"=1'-0"

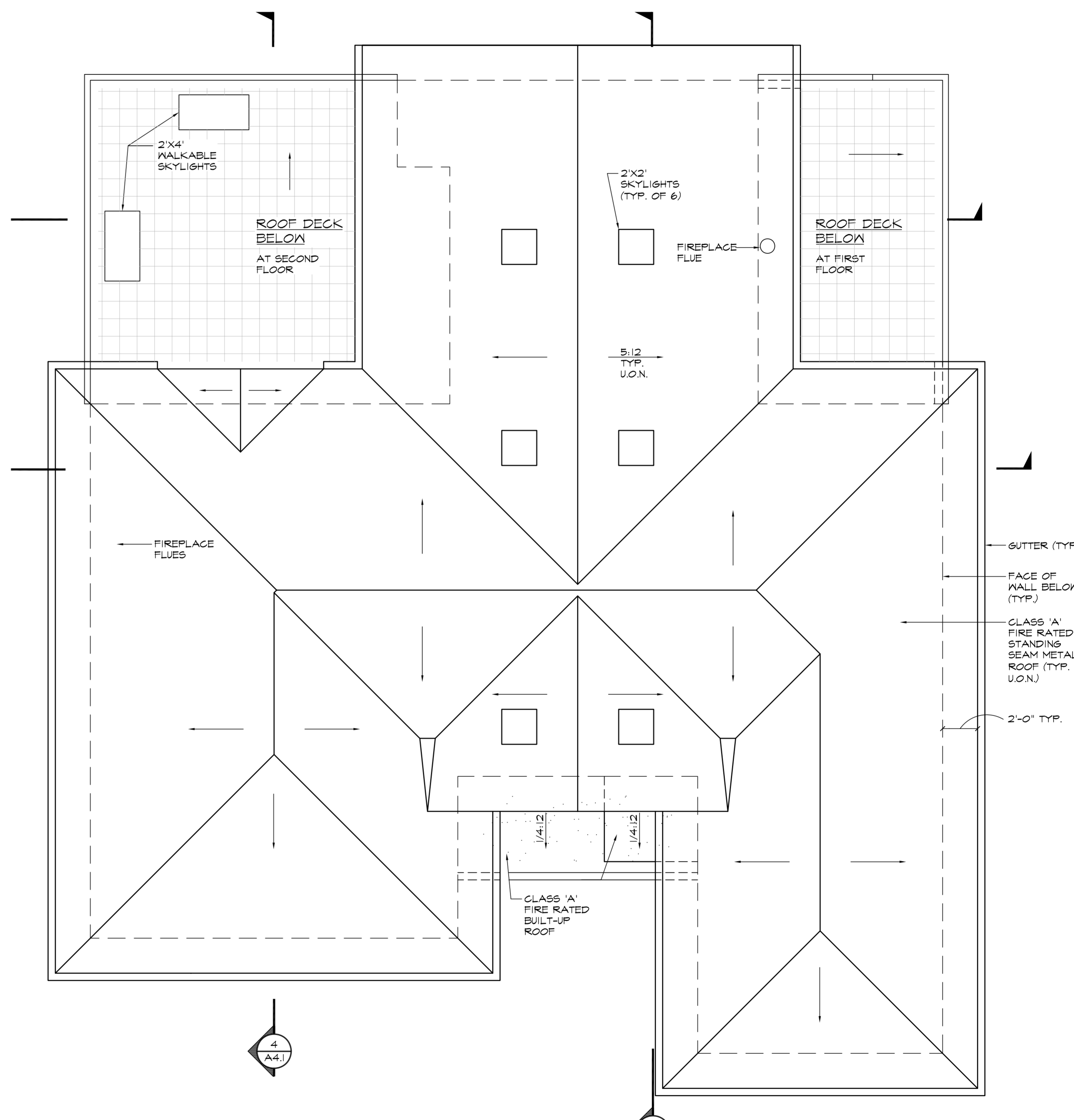

1 Roof Plan

1/4"=1'-0"

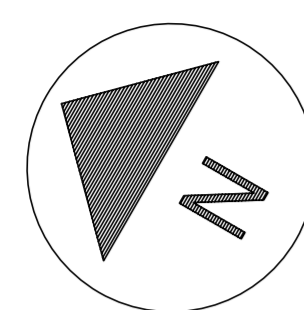

LOT 45
LOS TRANCOS WOODS TRACT NO. 1
VOL. 17 MAPS PAGES 14-15
7026 Sq Ft
0.16 Ac

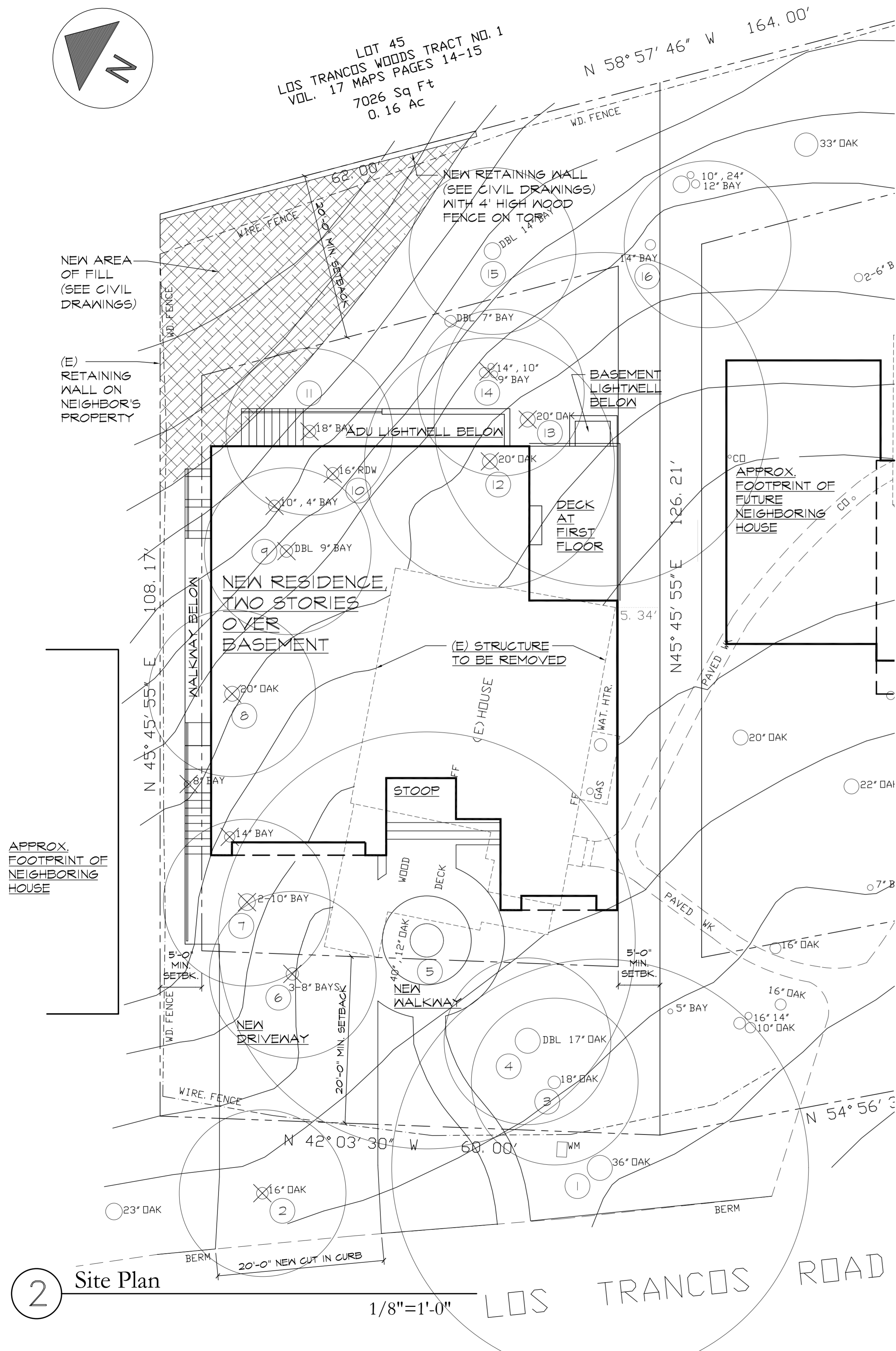







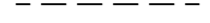

2 Site Plan

1/8"=1'-0"

LOS TRANCOS ROAD

LEGEND AND NOTES

-  NEW CONSTRUCTION:
EXTERIOR WALLS ARE 2X6 STUDS, TYPICAL, U.O.N.
INTERIOR WALLS ARE 2X4 STUDS, TYP., U.O.N.
-  1-HR. FIRE RATED CONSTRUCTION
-  NEW CONCRETE WALL S.S.D.
-  CABINET ABOVE OR ELEMENT BELOW
-  ELEMENT ABOVE
-  WOOD SHELF AND ROD
-  DOOR REFERENCE
-  WINDOW REFERENCE
-  KEY NOTE REFERENCE

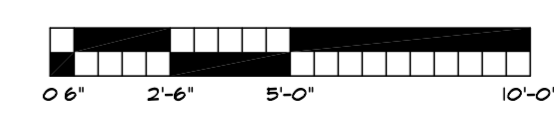
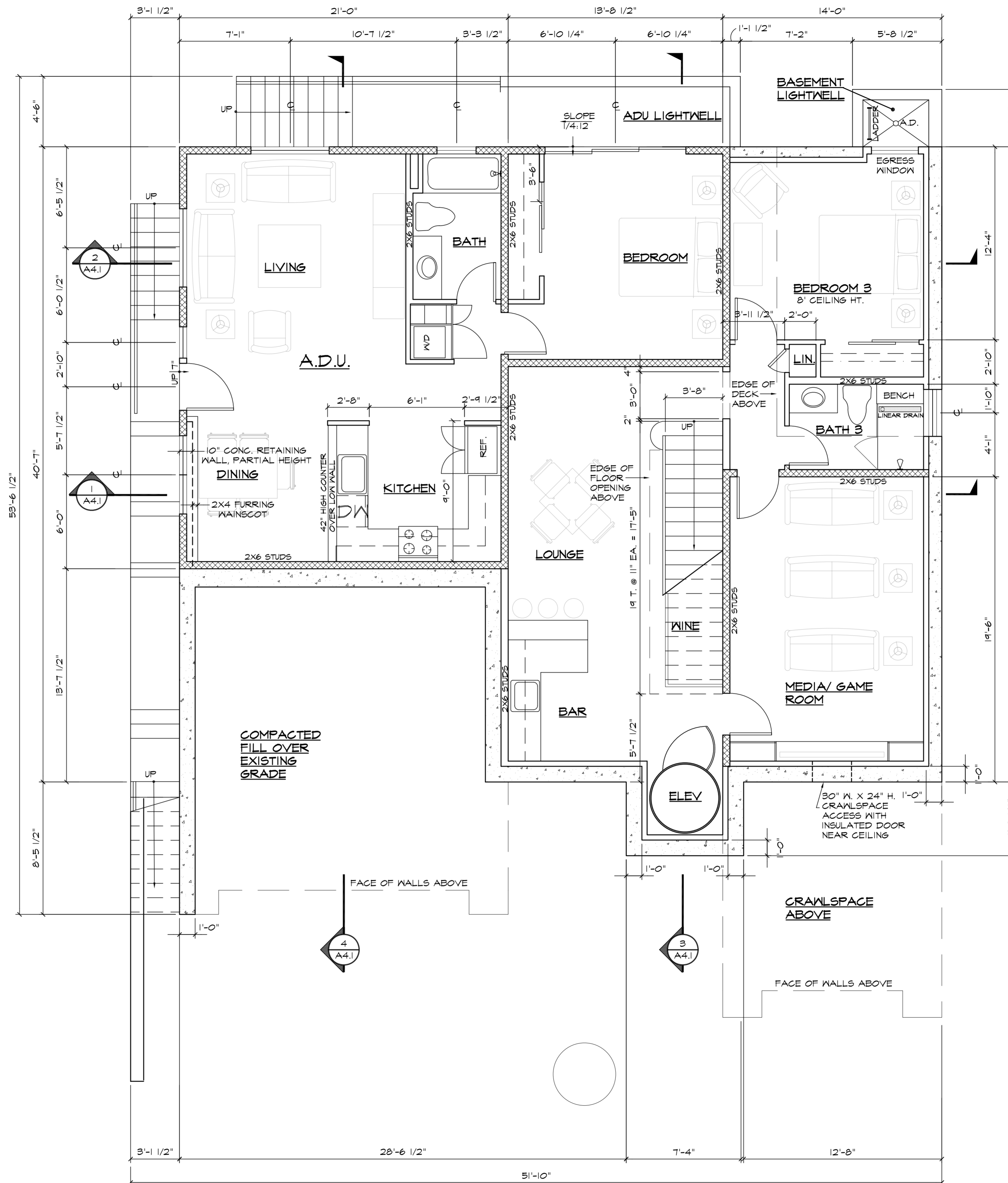

1 Basement Plan

1/4" = 1'-0"

1908Plan45



478 MONTEREY ROAD
PACIFICA, CA 94044
415.587.2004
www.beausoleil-architects.com

Submittal:

OWNER REVIEW	6.1.20
GRADING/TREE PERM.	10.14.20
TO STRUCT. ENG.	10.28.20
PLANNING REVIEW	6.17.21

New Residence
1061 Los Trancos
Lot 45
Portola Valley, CA

These Documents are a "builder's set" intended for use by a qualified, experienced general contractor using qualified, experienced subcontractors and suppliers. Details, materials, systems, and methods not specified herein are fully the responsibility of the General Contractor, his subcontractors, and installers.

Sheet Title
BASEMENT PLAN

Scale 1/4" = 1'-0"
Project No. 1908
Drawn By CB/RB

A2.1

LEGEND AND NOTES

- NEW CONSTRUCTION;
EXTERIOR WALLS ARE 2X6 STUDS, TYPICAL, U.O.N.
INTERIOR WALLS ARE 2X4 STUDS, TYP., U.O.N.
- 1-HR. FIRE RATED CONSTRUCTION
- NEW CONCRETE WALL S.S.D.
- CABINET ABOVE OR ELEMENT BELOW
- ELEMENT ABOVE
- WOOD SHELF AND ROD
- DOOR REFERENCE
- WINDOW REFERENCE
- KEY NOTE REFERENCE

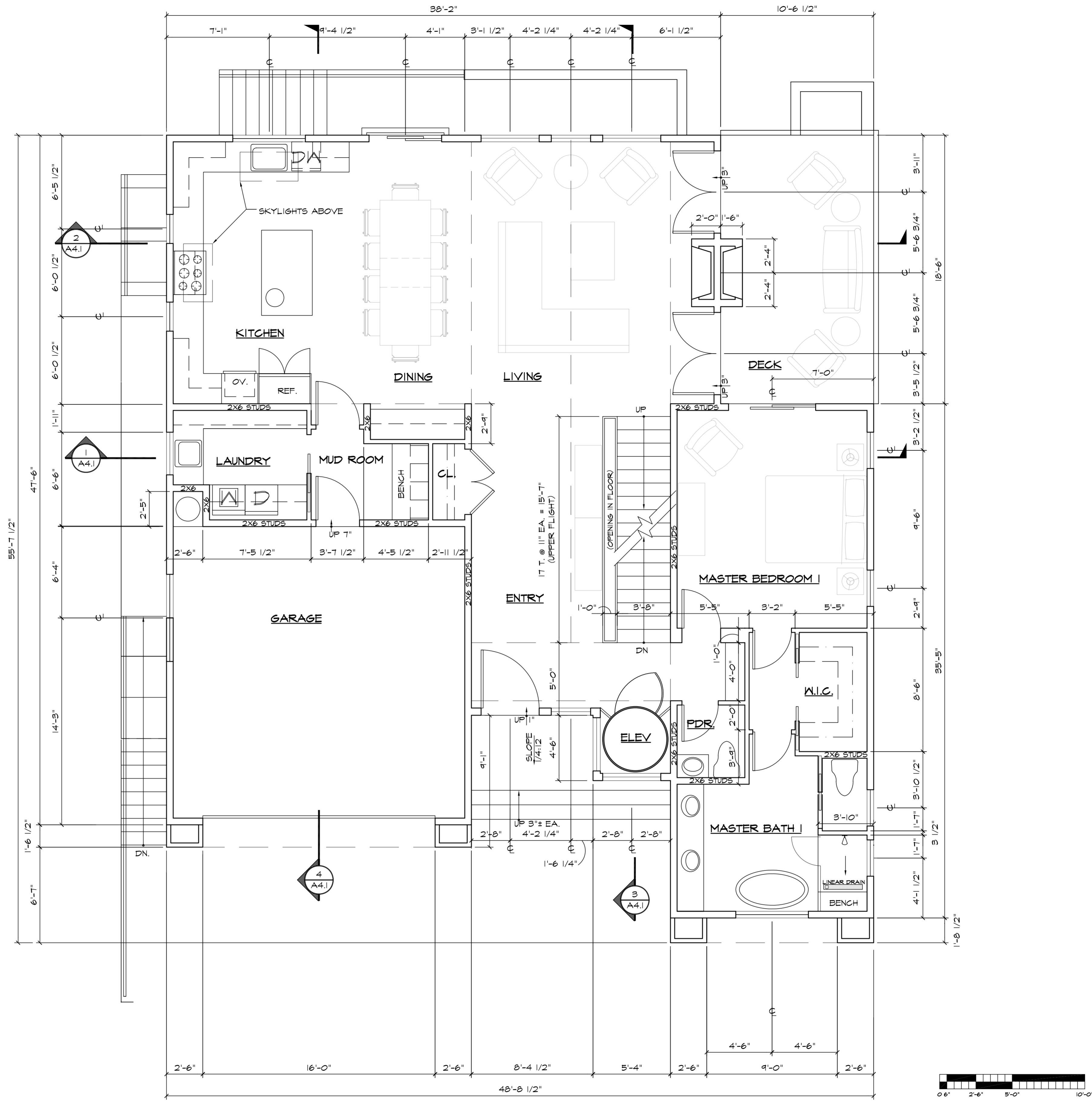

1 First Floor Plan

1/4" = 1'-0"

1908Plan45



478 MONTEREY ROAD
PACIFICA, CA 94044
415.587.2004
www.beausoleil-architects.com

Submittal:

OWNER REVIEW	6.1.20
GRADING/TREE PERM.	10.14.20
TO STRUCT. ENG.	10.28.20
PLANNING REVIEW	6.17.21

New Residence
1061 Los Trancos
Lot 45
Portola Valley, CA







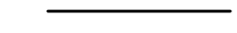

These Documents are a "builder's set" intended for use by a qualified, experienced general contractor using qualified, experienced subcontractors and suppliers. Details, materials, systems, and methods not specified herein are fully the responsibility of the General Contractor, his subcontractors, and installers.

Sheet Title
FIRST FLOOR
PLAN

Scale 1/4" = 1'-0"
Project No. 1908
Drawn By CB/RB

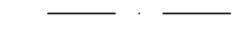
A2.2

LEGEND AND NOTES

-  NEW CONSTRUCTION.
 EXTERIOR WALLS ARE 2X6 STUDS, TYPICAL, U.O.N.
 INTERIOR WALLS ARE 2X4 STUDS, TYP., U.O.N.
-  1-HR. FIRE RATED CONSTRUCTION
-  NEW CONCRETE WALL S.S.D.
-  CABINET ABOVE OR ELEMENT BELOW
-  ELEMENT ABOVE
-  WOOD SHELF AND ROD
-  DOOR REFERENCE
-  WINDOW REFERENCE
-  KEY NOTE REFERENCE

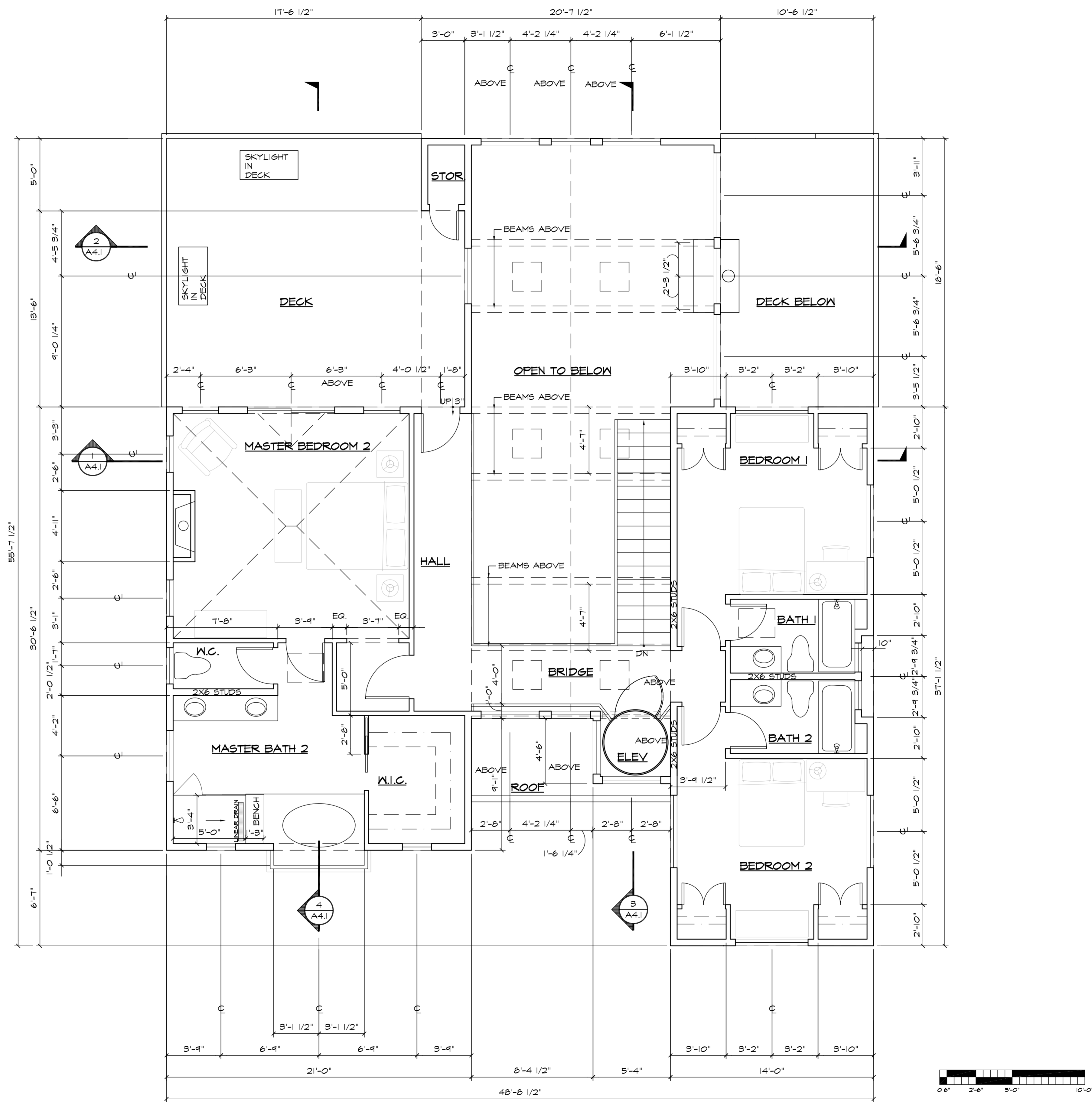

1 Second Floor Plan

1/4" = 1'-0"

1908Plan45



478 MONTEREY ROAD
 PACIFICA, CA 94044
 415.587.2004
 www.beausoleil-architects.com

Submittal:

OWNER REVIEW	6.1.20
GRADING/TREE PERM.	10.14.20
TO STRUCT. ENG.	10.28.20
PLANNING REVIEW	6.17.21

New Residence
 1061 Los Trancos
 Lot 45
 Portola Valley, CA

These Documents are a 'builder's set' intended for use by a qualified, experienced general contractor using qualified, experienced subcontractors and suppliers. Details, materials, systems, and methods not specified herein are fully the responsibility of the General Contractor, his subcontractors, and installers.

Sheet Title
SECOND FLOOR PLAN

Scale 1/4"=1'-0"
 Project No. 1908
 Drawn By CB/RB

A2.3



478 MONTEREY ROAD
PACIFICA, CA 94044
415.587.2004
www.beausoleil-architects.com

Submittal:

OWNER REVIEW	6.1.20
GRADING/TREE PERM.	10.14.20
TO STRUCT. ENG.	10.28.20
PLANNING REVIEW	6.17.21



2 Front (Southeast) Elevation
3/16"=1'-0"



1 Right Side (Northeast) Elevation
3/16"=1'-0"

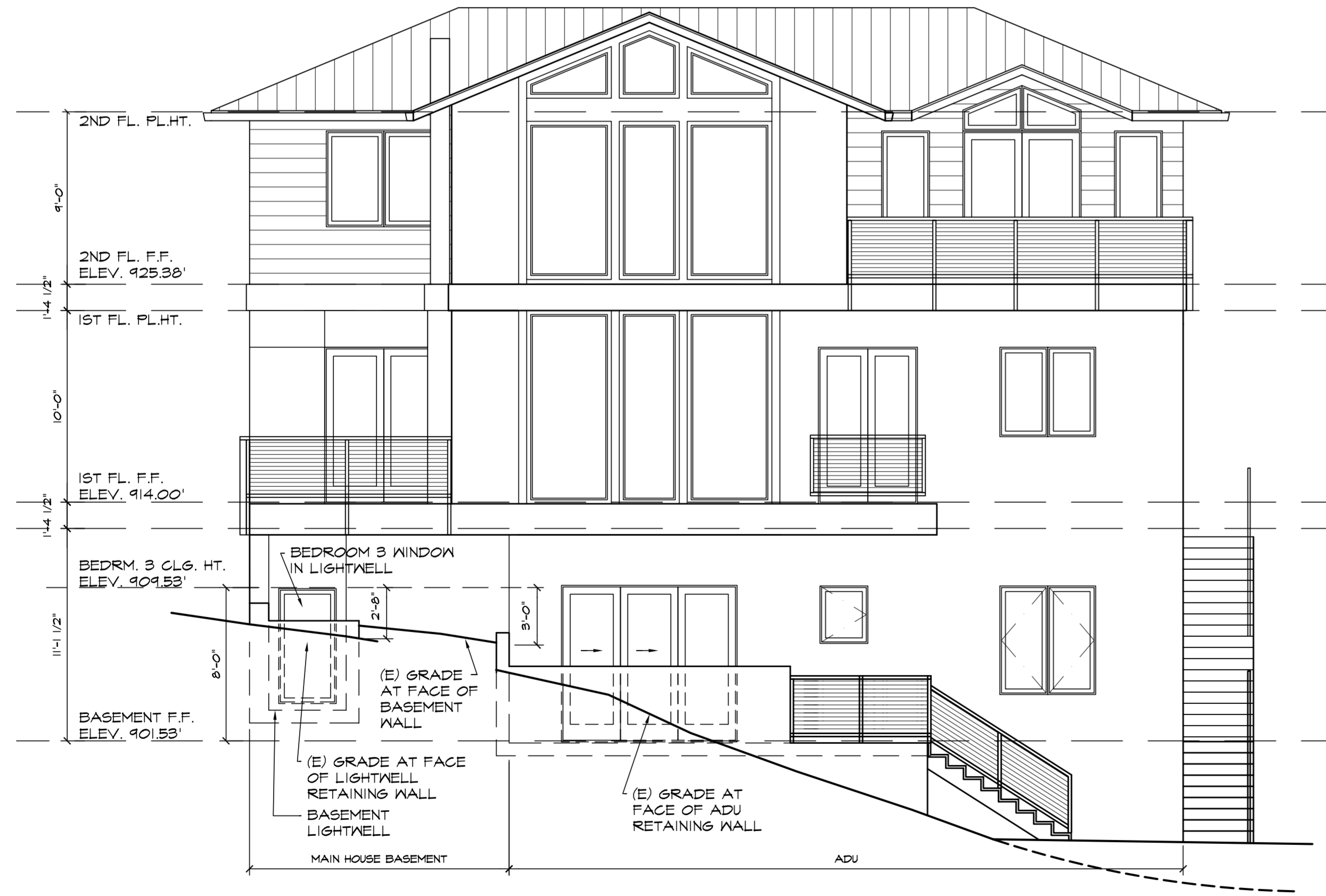

4 Rear (Northwest) Elevation
3/16"=1'-0"



3 Left Side (Southwest) Elevation
3/16"=1'-0"

New Residence
1061 Los Trancos
Lot 45
Portola Valley, CA

These Documents are a 'builder's set' intended for use by a qualified, experienced general contractor using qualified, experienced subcontractors and suppliers. Details, materials, systems, and methods not specified herein are fully the responsibility of the General Contractor, his subcontractors, and installers.

Sheet Title
ELEVATIONS

Scale 3/16"=1'-0"
Project No. 1908
Drawn By CB/RB

A3.1

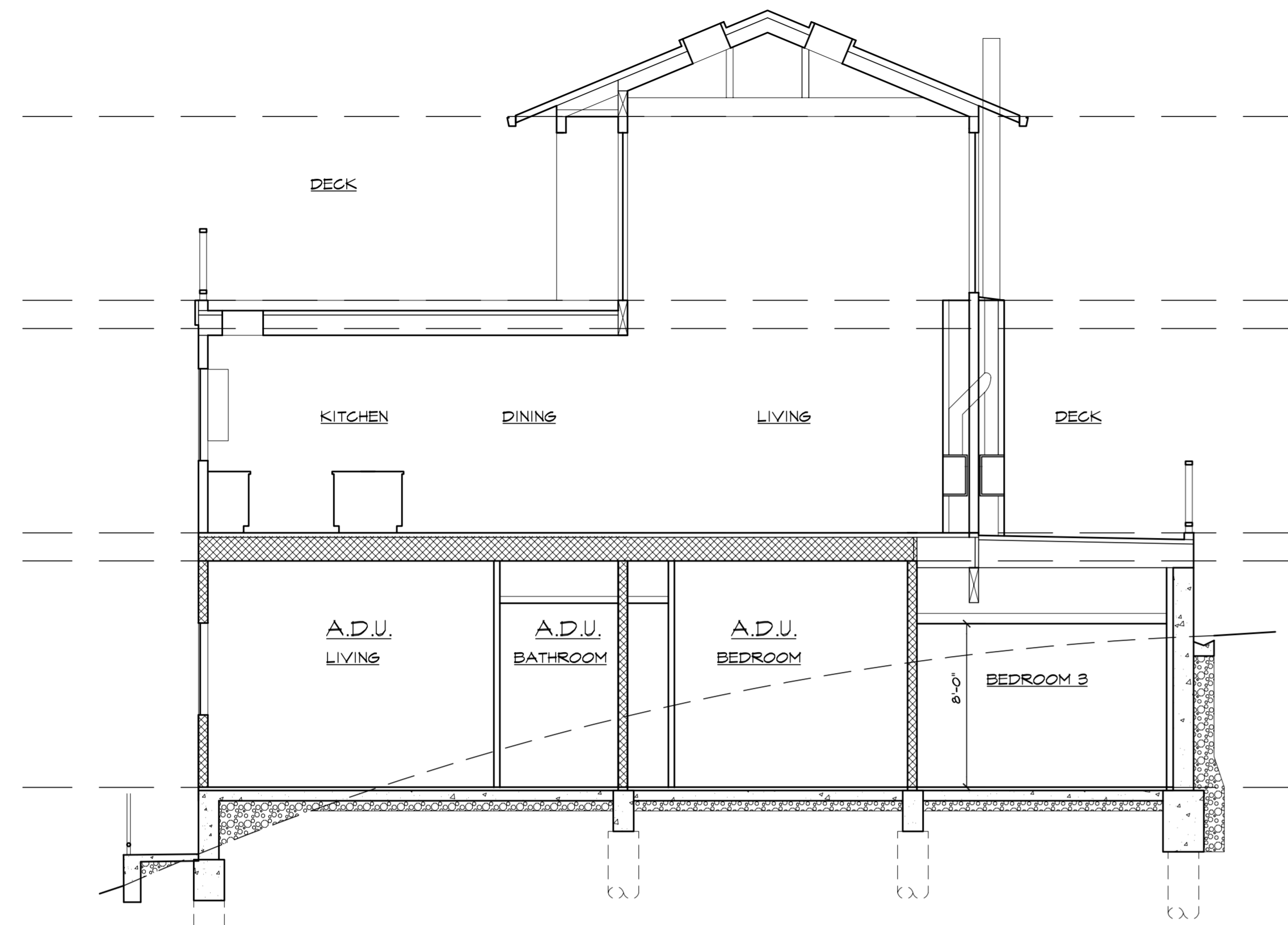

2 Building Section
3/16"=1'-0"

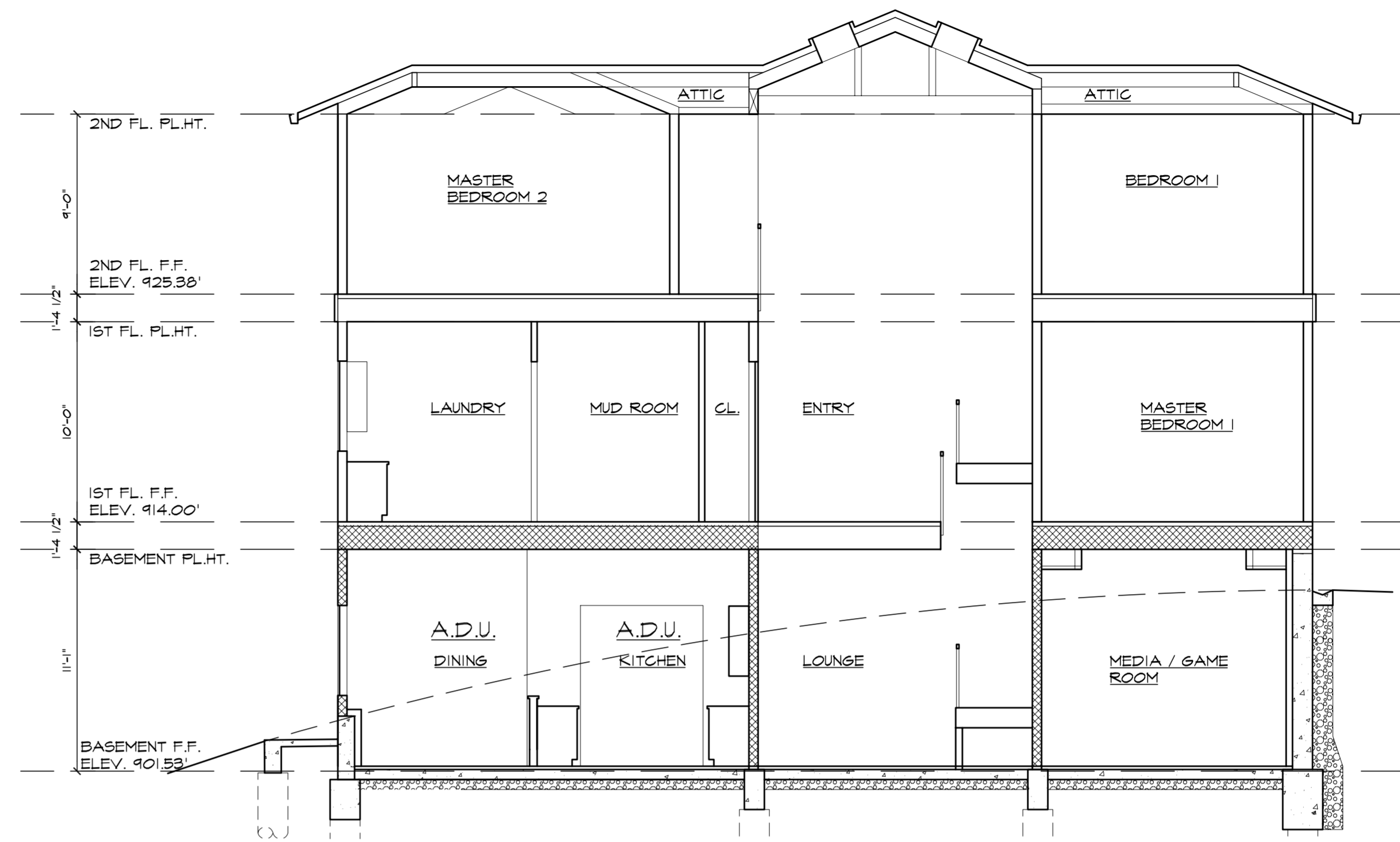

1 Building Section
3/16"=1'-0"

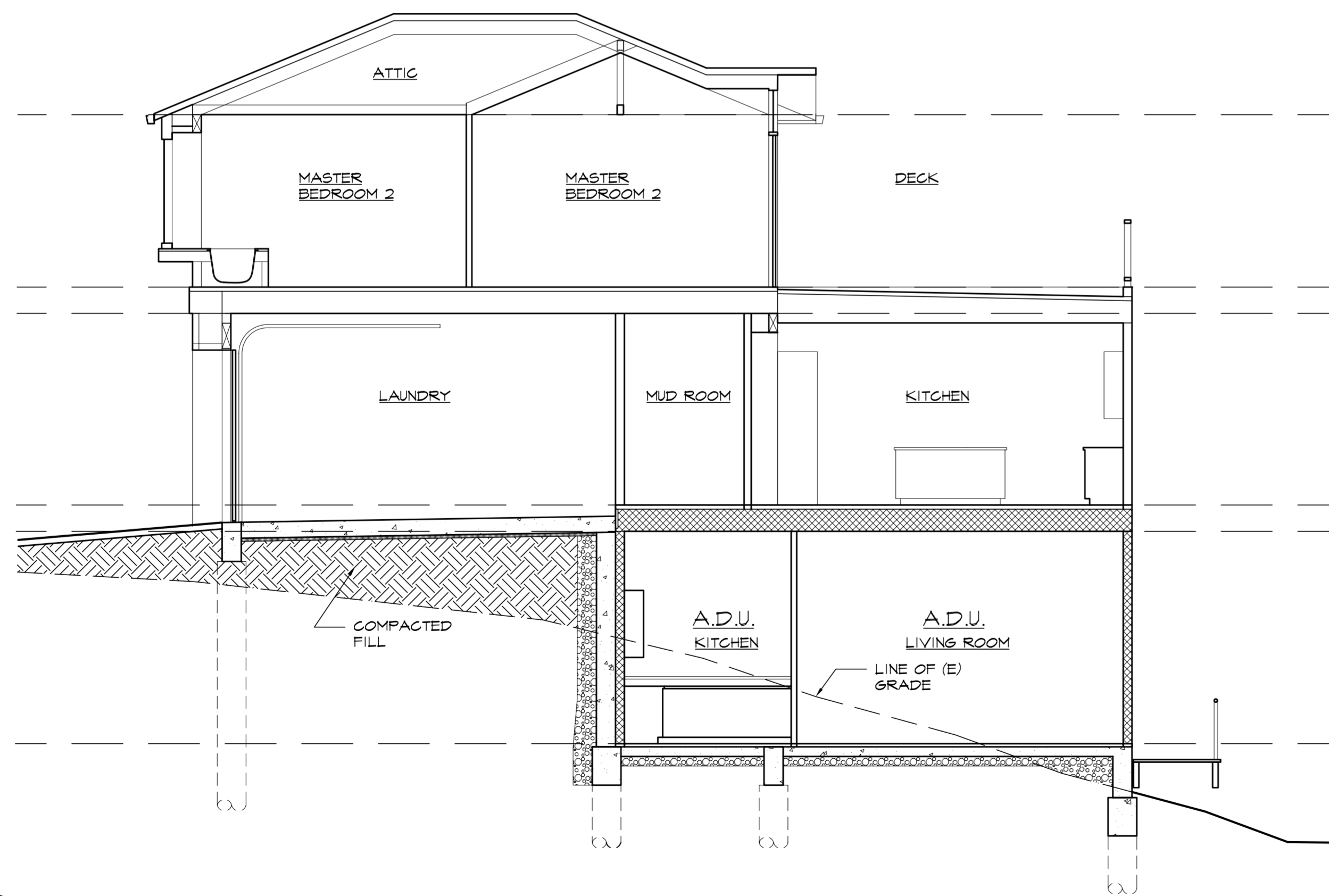

4 Building Section
3/16"=1'-0"

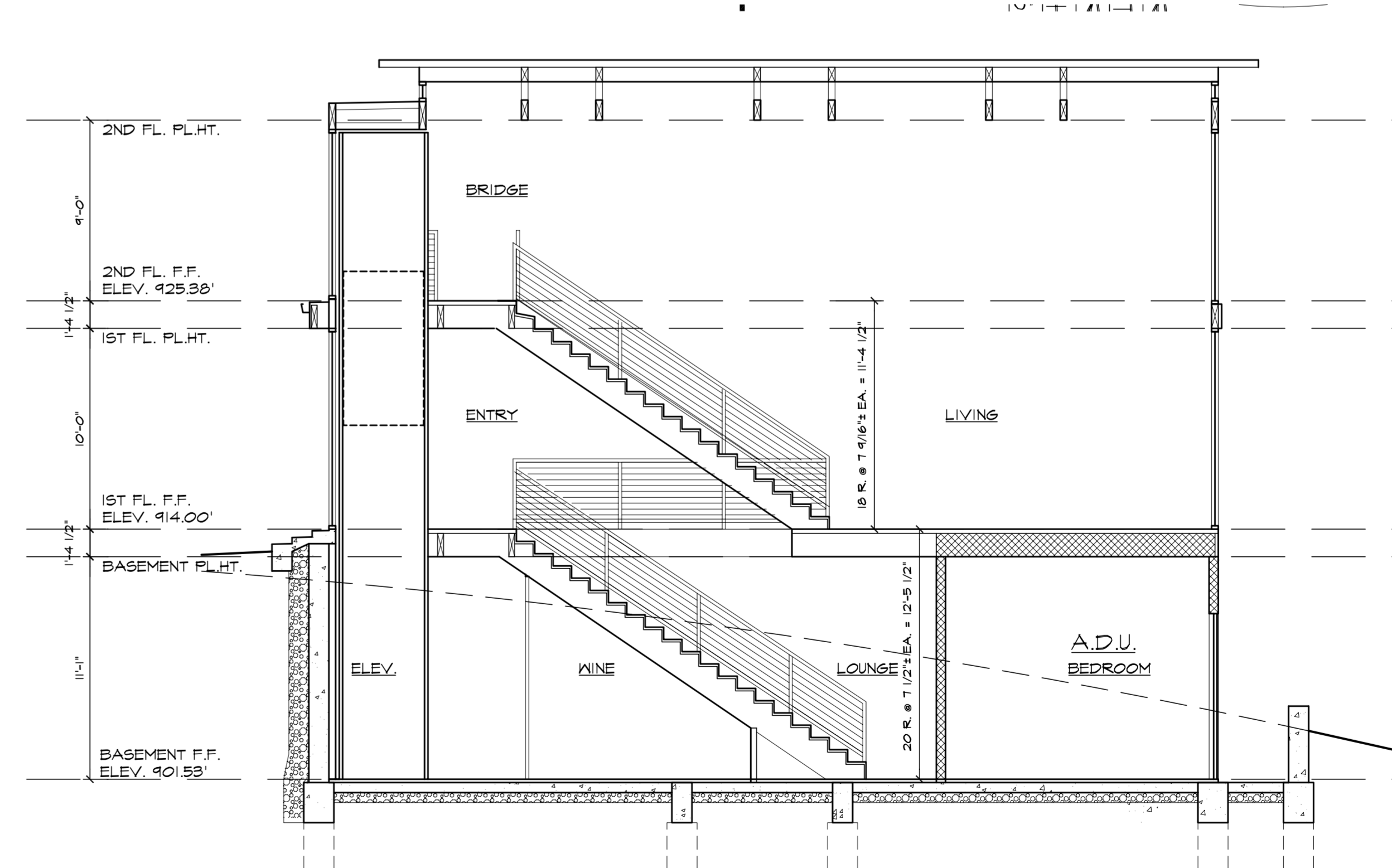

3 Building Section
3/16"=1'-0"



478 MONTEREY ROAD
PACIFICA, CA 94044
415.587.2004
www.beausoleil-architects.com

Submittal:

OWNER REVIEW	6.1.20
GRADING/TREE PERM.	10.14.20
TO STRUCT. ENG.	10.28.20
PLANNING REVIEW	6.17.21

New Residence
1061 Los Trancos
Lot 45
Portola Valley, CA

These Documents are a 'builder's set' intended for use by a qualified, experienced general contractor using qualified, experienced subcontractors and suppliers. Details, materials, systems, and methods not specified herein are fully the responsibility of the General Contractor, his subcontractors, and installers.

Sheet Title
BUILDING SECTIONS
Scale 3/16"=1'-0"
Project No. 1908
Drawn By CB/RB

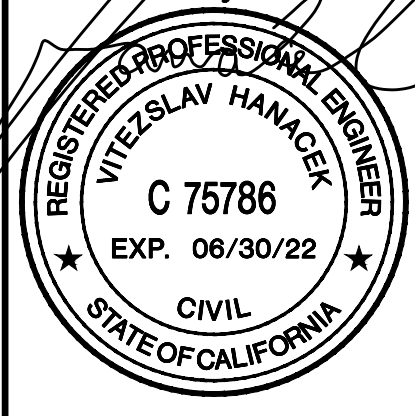

LEGEND

- RETAINING WALL
- FILL AREA AND BOUNDARY
- CUT AREA AND BOUNDARY
- INTERLOCKING PERMEABLE PAVERS
- CONC. PAVEMENT OVER 8" CALTRANS CLASS II BASE
- (N) CONTOUR LINES
- BUILDING OUTLINE
- PROPERTY LINE
- (E) CONTOUR LINES
- DRAIN INLET

ABBREVIATIONS

AB	AGGREGATE BASE
AC	ASPHALTIC CONCRETE
BFPD	BACKFLOW PREVENTION DEVICE
BLDG	BUILDING
BOP	BOTTOM OF PIPE
BSMT	BASEMENT
BW	BACK OF WALK
CB	CATCH BASIN
C&G	CURB & GUTTER
CI	CURB INLET
CIP	CAST IRON PIPE
CLF	CHAIN LINK FENCE
CONC	CONCRETE
COO	CITY OF OAKLAND
COR	CORNER
C.Y.	CUBIC YARDS
DI	DRAINAGE INLET
DIP	DUCTILE IRON PIPE
DW	DOMESTIC WATER
D/W	DRIVEWAY
E	EAST
(E) EX	EXISTING
EBMUD	EAST BAY MUD
EFG	EXISTING FINISH GRADE
ELEC	ELECTRICAL
EP	EDGE OF PAVEMENT
FC	FACE OF CURB
FF	FINISHED FLOOR
FG	FINISH GRADE
FL	FLOW LINE
FLR	FLOOR
FND	FOUND
FS	FIRE SERVICE OR FINISHED SURFACE ELEVATION
G	GAS
GB	GRADE BREAK
GS	GROUND SURFACE ELEVATION
GV	GAS VALVE
HC	HANDICAP
HCR	HANDICAP RAMP
HP	HIGH POINT
INV	INVERT ELEVATION
IRR	IRRIGATION
JP	JOINT POLE
JT	JOINT TRENCH
LAT	LATERAL
LG	LIP OF GUTTER
LP	LOW POINT
M.M	MONUMENT TO MONUMENT
(N)	NEW
N	NORTH
NE	NORTH EAST
NO	NUMBER
NW	NORTH WEST
OPT	OPTION
OVE	OVERHEAD ELECTRIC
PC	POINT OF CURVATURE
PL	PROPERTY LINE
POC	POINT OF CONNECTION
PP	POWER POLE
PRK	PARKING
PT	POINT OF TANGENCY
PVC	POLYVINYL CHLORIDE
PVMT	PAVEMENT
RCP	REINFORCED CONCRETE PIPE
RFBPD	REDUCED PRESSURE BACKFLOW PREVENTION DEVICE
S	SLOPE OR SOUTH
SAP	SEE ARCHITECTURAL PLANS
SD	STORM DRAIN
SDCB	STORM DRAIN CATCH BASIN
SDCO	STORM DRAIN CLEANOUT
SDMH	STORM DRAIN MANHOLE
SE	SOUTH EAST
SEP	SEE ELECTRICAL PLANS
SERV	SERVICE
SF	SQUARE FEET
SFPP	SEE FIRE PROTECTION PLANS
SGR	SEE GEOTECHNICAL REPORT
SHT	SHEET
SJTP	SEE JOINT TRENCH PLANS
SL	STREET LIGHT
SLP	SEE LANDSCAPE PLANS
SMP	SEE MECHANICAL PLANS
SPP	SEE PLUMBING PLANS
SS	SANITARY SEWER
SSCO	SANITARY SEWER CLEANOUT
SSLP	SEE STREET LIGHT PLAN
SSML	SANITARY SEWER MANHOLE
SSP	SEE STRUCTURAL PLAN
STA	STATION
STD	STANDART
SW	SOUTH WEST
S/W	SIDEWALK
TO	TOP OF CURB
TP	TOP OF PAVEMENT
THK	THICK
THRU	THROUGH
TOP	TOP OF PIPE
TRANS	TRANSFORMER
TW	TOP OF WALL
TYP	TYPICAL
VCP	VITRIFIED CLAY PIPE
W/	WITH
W	WATER
WM	WATER METER
W	WEST
WV	WATER VALVE

NOTES

1. THE TOPOGRAPHY SHOWN ON THE PLAN PROVIDED BY THE OWNER WAS BASED ON A SURVEY BY WESTFALL ENGINEERS, INC., DATED AUGUST 2019.
2. FOR BUILDING PLAN DRAWINGS SEE ARCHITECTURAL DESIGN.
3. FIVE FEET AROUND THE PERIMETER OF THE BUILDING PAD SHALL BE COMPACTED TO NOT LESS THAN 90% RELATIVE COMPACTION.
4. THE PROJECT GEOTECHNICAL ENGINEER SHALL BE ON SITE TO OBSERVE, TEST AND ADVISE DURING SITE PREPARATION, GRADING, EXCAVATION AND PLACEMENT OF STRUCTURAL FILL AND DURING EXCAVATIONS FOR PROPOSED BUILDING AND RETAINING WALLS.

LOCATION MAP

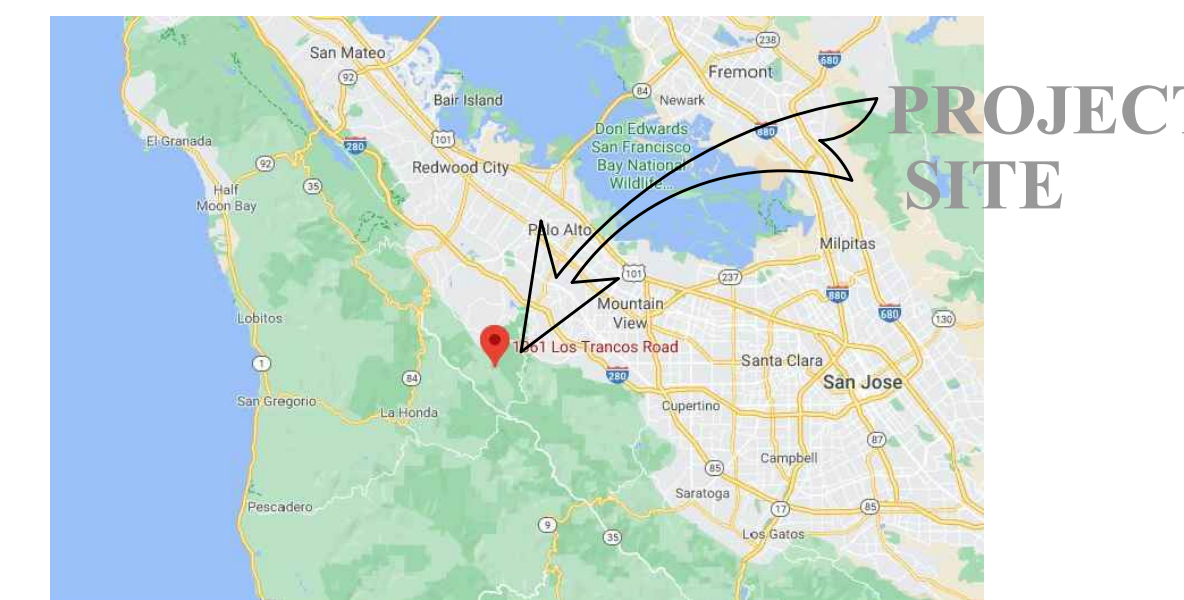

SHEET INDEX

C-1	SITE GRADING, PAVING AND DRAINAGE PLAN
C-2	SITE CROSS SECTIONS
C-3	SITE UTILITIES PLAN
C-4	CIVIL DETAILS
C-5	EROSION CONTROL PLAN AND DETAILS
C-6	STORM WATER MANAGEMENT PLAN
C-7	STORMWATER CONTROL CHECKLIST
C-8	SAN MATEO COUNTYWIDE BMPS

CUT AND FILL VOLUME [C.Y.D.]

	CUT [C.Y.]	FILL [C.Y.]
REAR YARD CORNER RETAINING WALL	±0	±63
DRIVEWAY	±0	±100
HOUSE BASEMENT	±278	±15
TOTAL VOLUME	±278	±178
TOTAL EXPORT	278-178=±100 CY	

THESE ARE ESTIMATED VALUES FOR BONDING PURPOSES ONLY. CONTRACTOR SHALL PERFORM THEIR OWN ESTIMATE FOR THE PURPOSE OF CONSTRUCTION QUANTITIES.

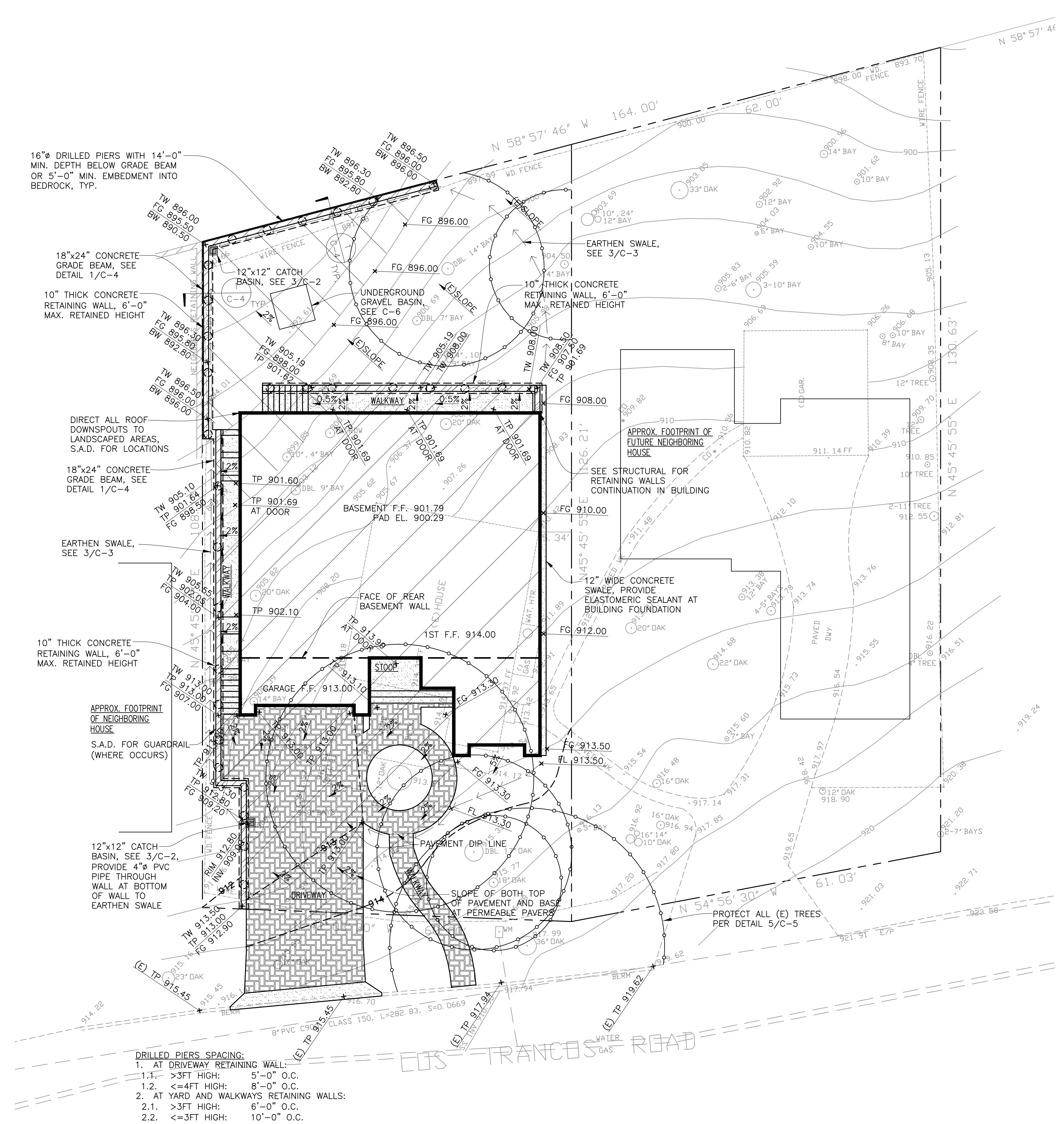

1 SITE GRADING AND PAVING PLAN
 SCALE: 1"=10'

ISSUANCE AND REVISIONS:	NO.	DATE	DESCRIPTION
	1	07/12/2021	PERMIT SET
	2	07/12/2021	ARBORIST COMMENTS

NEW SINGLE FAMILY HOME
 1061 LOS TRANCOS RD.
 PORTOLA VALLEY, CA

OVERALL SITE GRADING AND PAVING PLAN, NOTES, VICINITY MAP, LEGEND

SHEET NO.: **C-1**
 PROJECT: 20-0654

Vit Hanacek Engineering
 2912 Vessing Rd.
 Pleasant Hill, CA 94523
 Tel. (925) 262-7401
 Fax. (925) 952-7812
 v.hanacek@yahoo.com

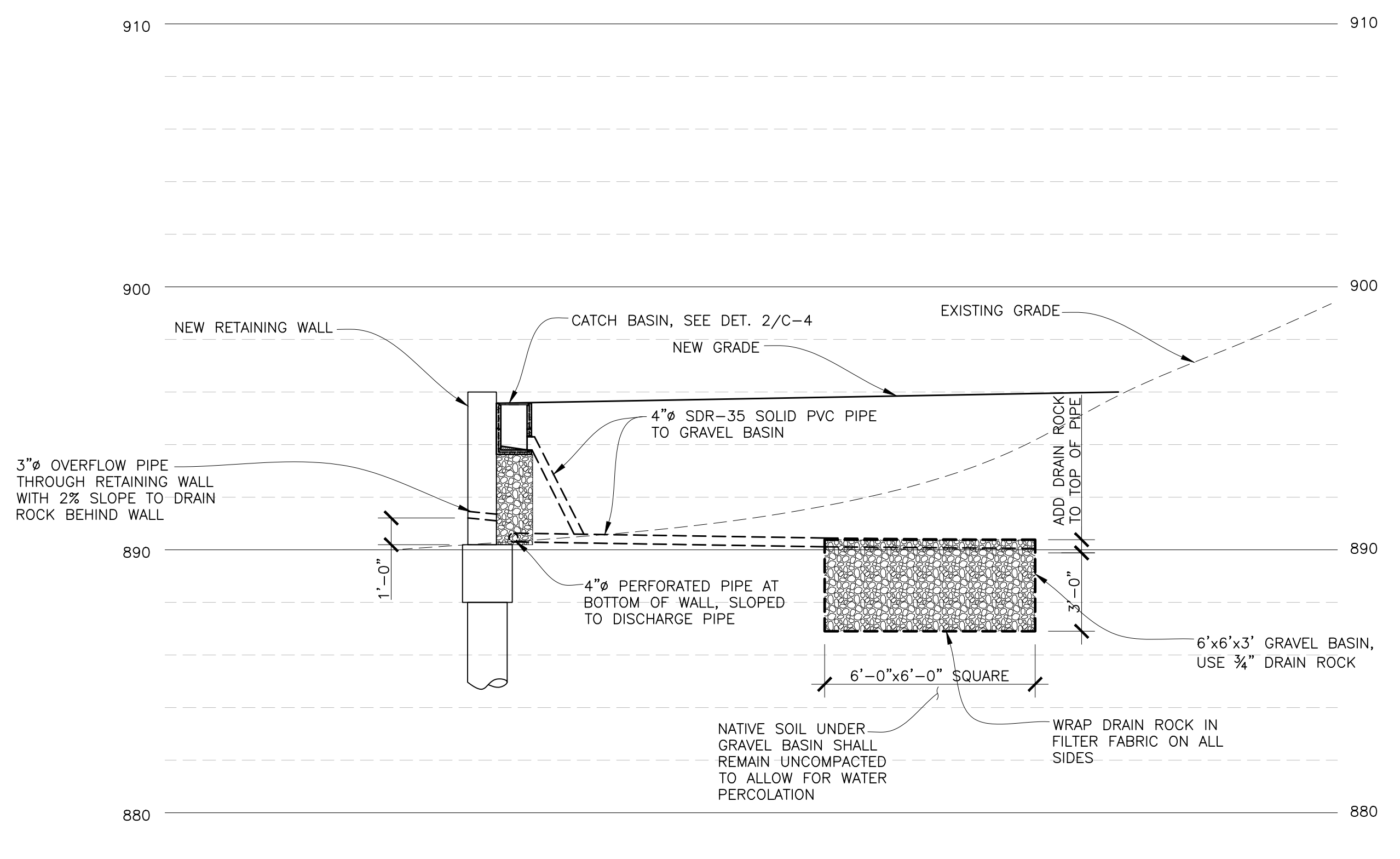
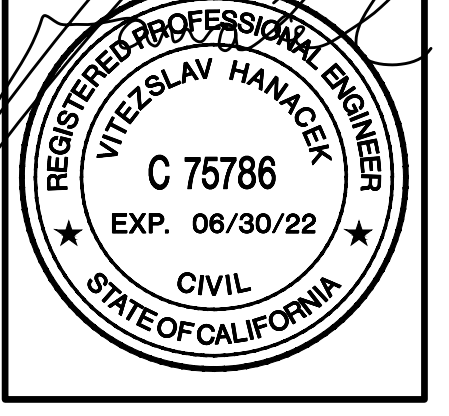

1 CROSS SECTION AT GRAVEL BASIN AND RETAINING WALL
 SCALE: 1/4"=1'-0"

ISSUANCE AND REVISIONS:	
NO.	DESCRIPTION
10/14/2020	PERMIT SET
01/12/2021	ARBORIST COMMENTS

PROJECT NAME:
NEW SINGLE FAMILY HOME
 1061 LOS TRANCOS RD.
 PORTOLA VALLEY, CA

SHEET TITLE:
 SITE CROSSSECTIONS

Vit Hanacek Engineering
 2912 Vessing Rd.
 Pleasant Hill, CA 94523
 Tel. (925) 262-7401
 Fax. (925) 952-7812
 v.hanacek@yahoo.com

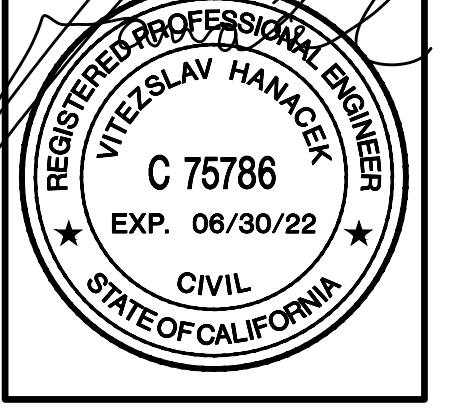

ISSUANCE AND REVISIONS:	NO.	DATE	DESCRIPTION
	1	01/12/2021	ARBITRIST COMMENTS

PROJECT NAME:
NEW SINGLE FAMILY HOME
 1061 LOS TRANCOS RD.
 PORTOLA VALLEY, CA

SHEET TITLE:
 SITE UTILITIES PLAN

SHEET NO.:
C-3
 PROJECT: 20-0654

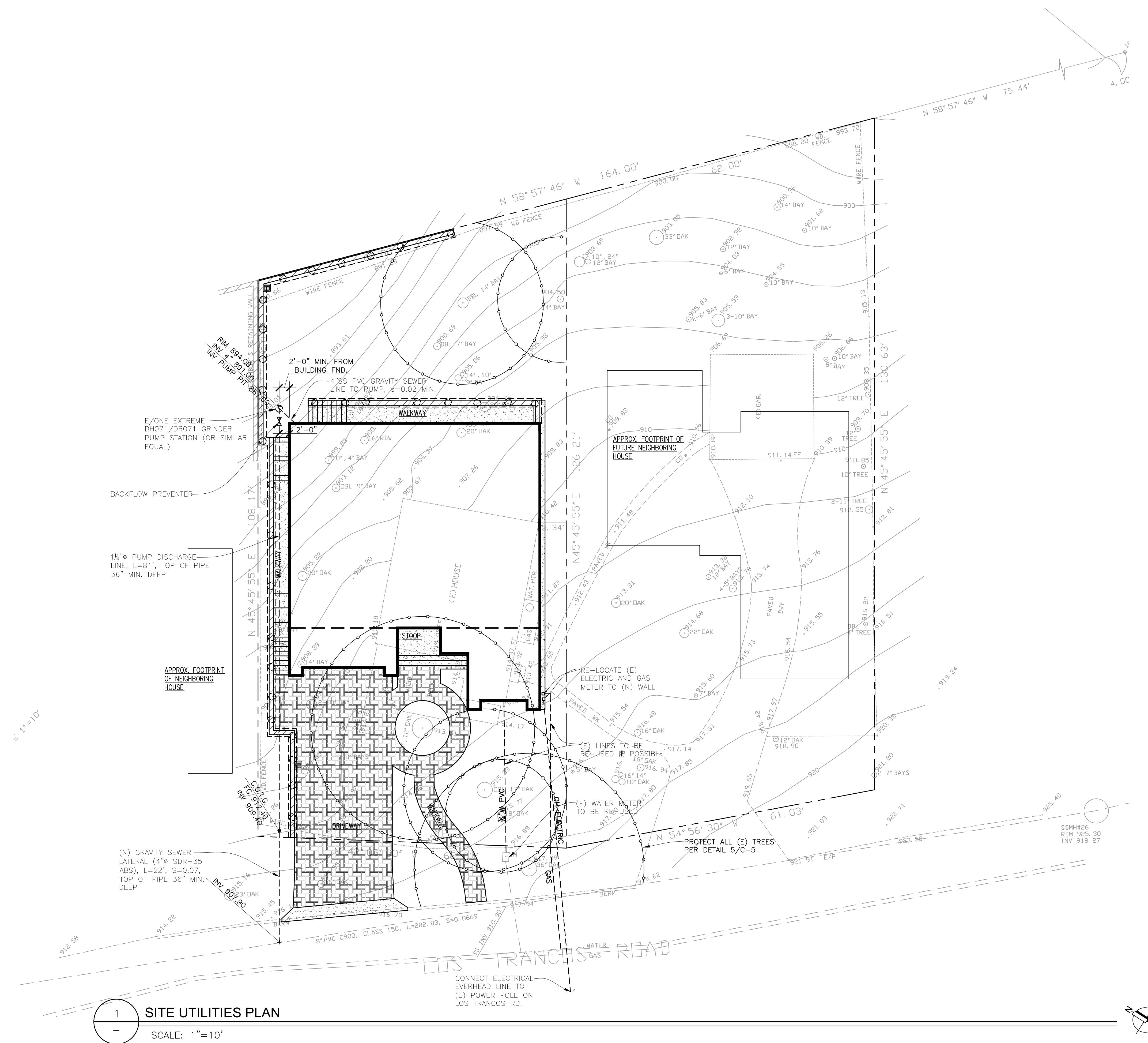

1 SITE UTILITIES PLAN
 SCALE: 1" = 10'

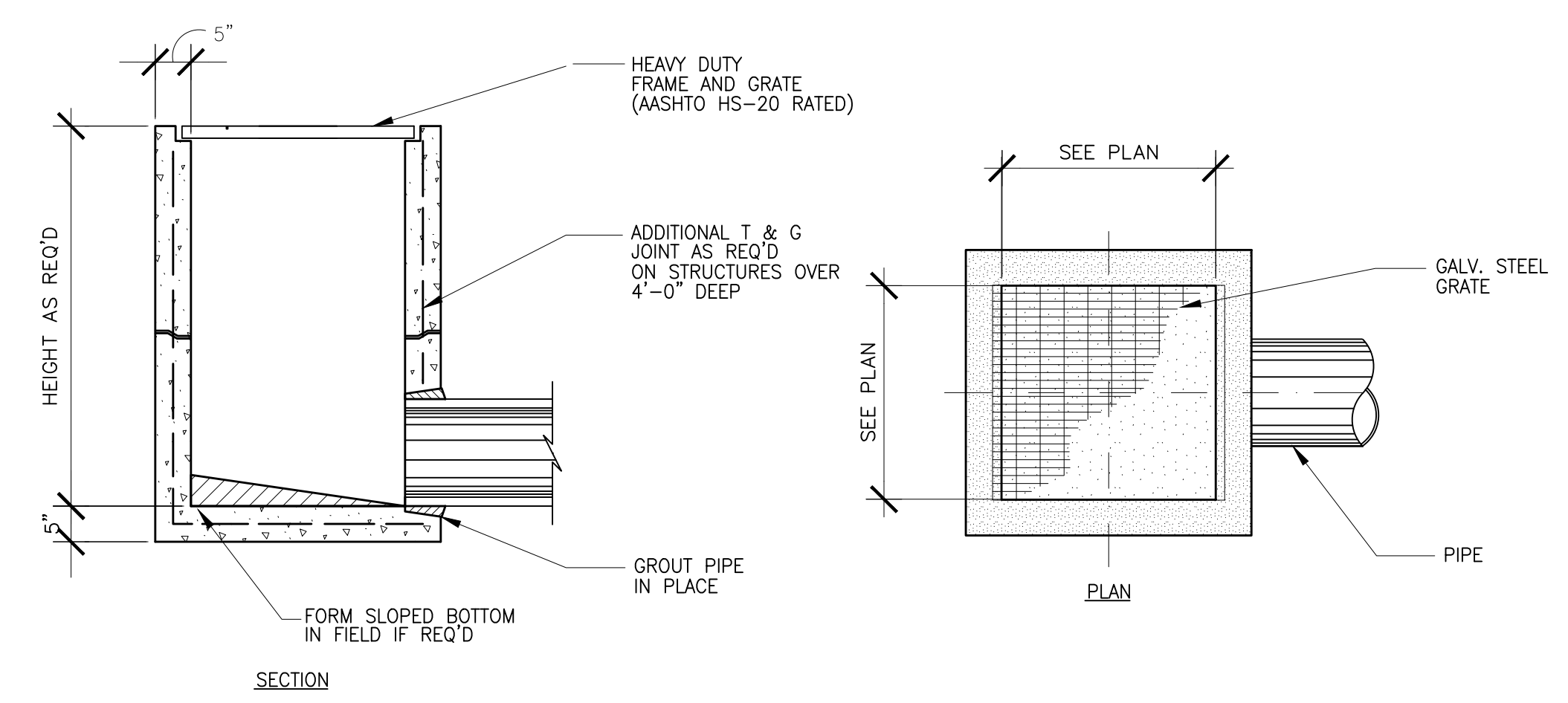

2 CATCH BASIN
 NOT TO SCALE

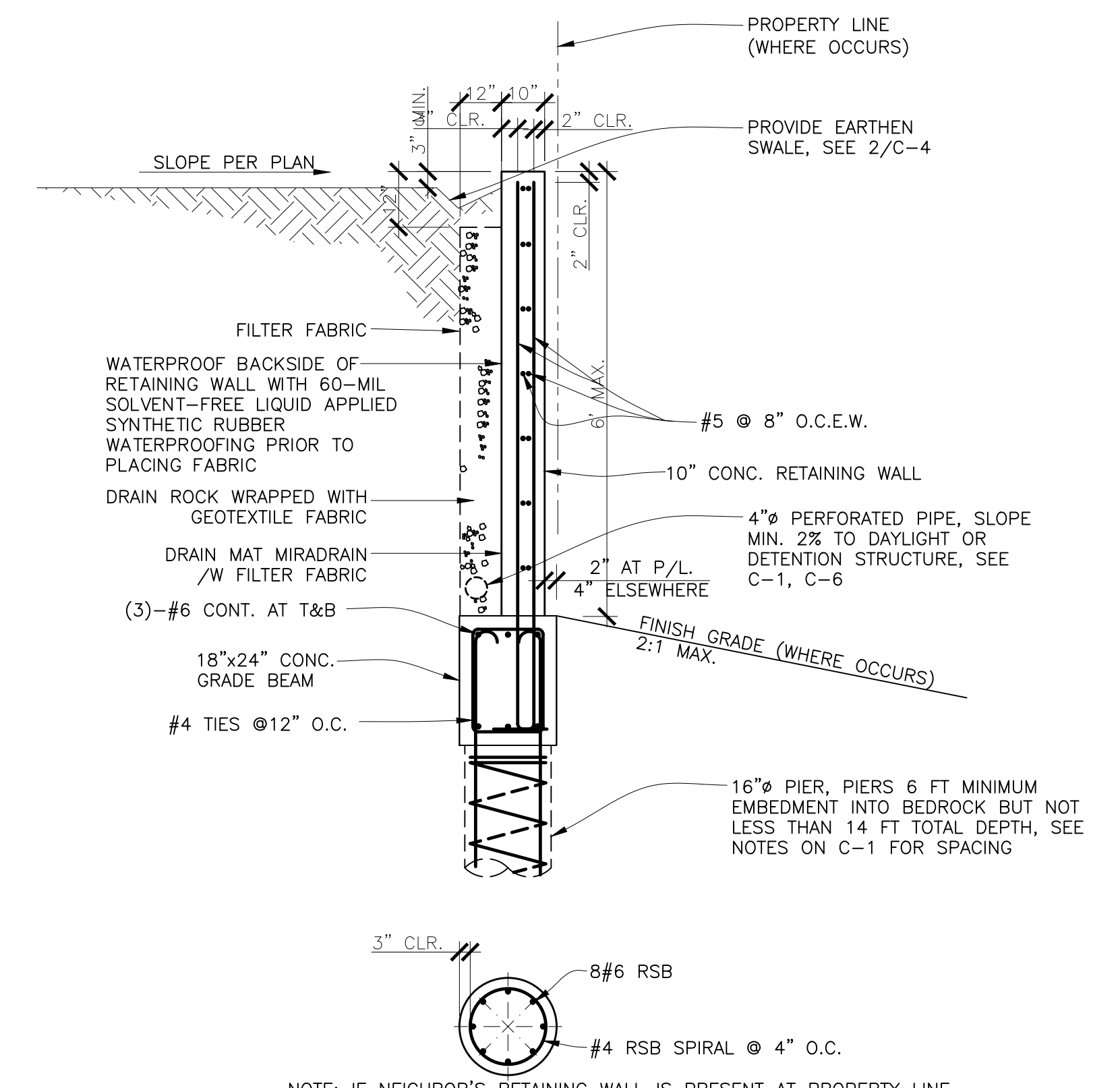

1 CONCRETE RETAINING WALL SECTION
 NOT TO SCALE

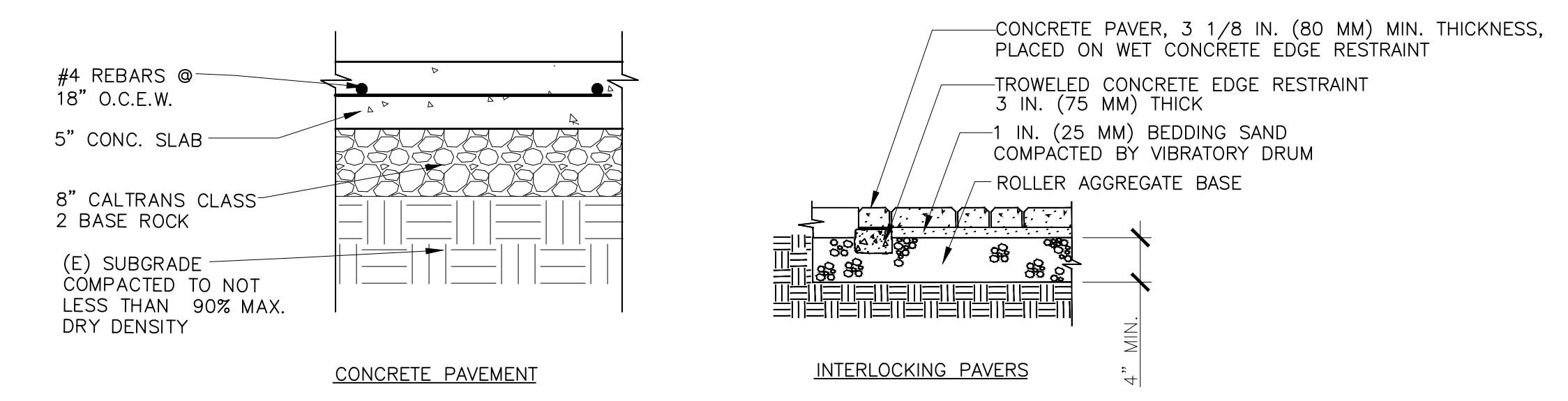

4 PAVEMENT SECTION
 NOT TO SCALE

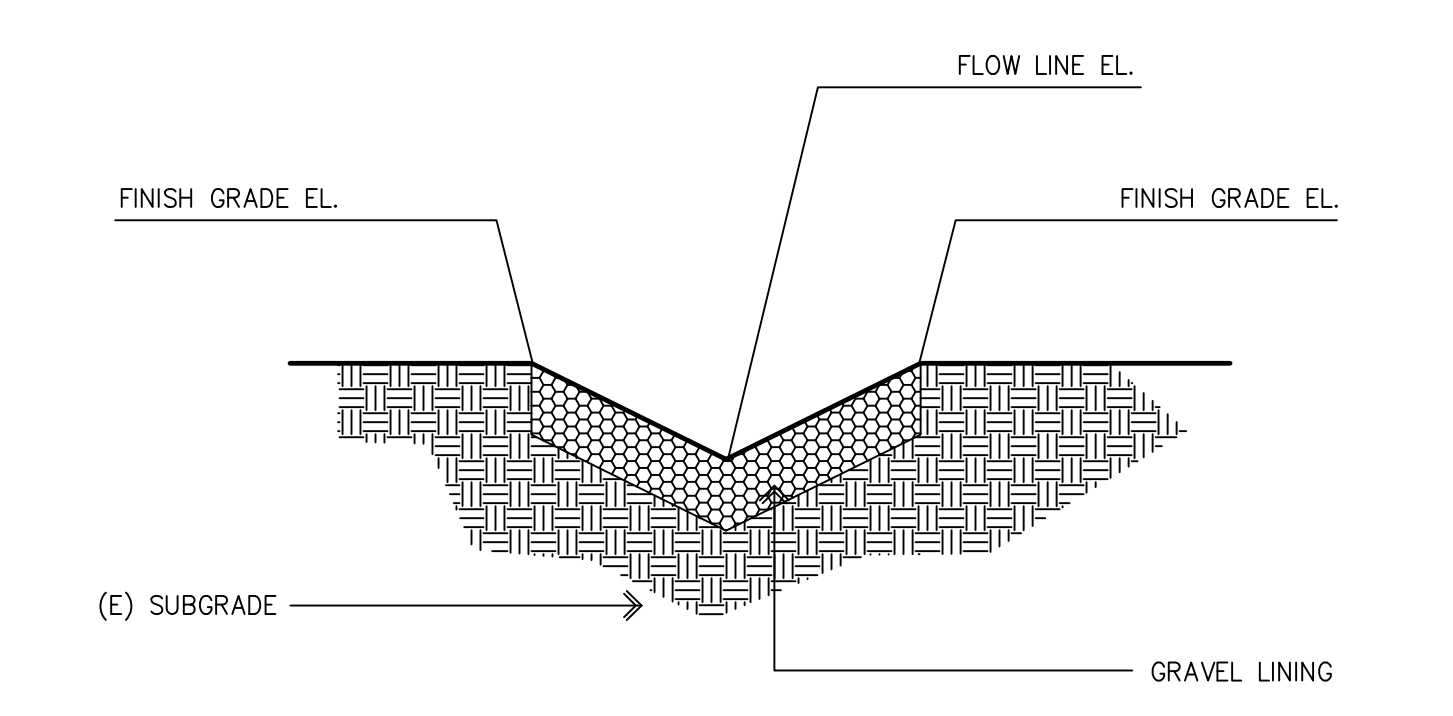

3 TYPICAL EARTHEN SWALE
 NOT TO SCALE

ISSUANCE AND REVISIONS:	NO.	DATE	DESCRIPTION
	1	01/12/2021	PERMIT SET
			ARBORIST COMMENTS

PROJECT NAME:
NEW SINGLE FAMILY HOME
 1061 LOS TRANCOS RD.
 PORTOLA VALLEY, CA

SHEET TITLE:
 CIVIL DETAILS

ISSUANCE AND REVISIONS:	NO.	DATE	DESCRIPTION
	1	10/14/2020	PERMIT SET
	2	01/12/2021	ARBORIST COMMENTS

NEW SINGLE FAMILY HOME
 1061 LOS TRANCOS RD.
 PORTOLA VALLEY, CA

EROSION CONTROL PLAN AND DETAILS

EROSION PREVENTION AND SEDIMENT CONTROL NOTES

- PHASE GRADING OPERATIONS TO REDUCE DISTURBED AREAS AND TIME OF EXPOSURE.
- NO SITE GRADING SHALL BE ALLOWED BETWEEN OCTOBER 15TH AND APRIL 15TH UNLESS APPROVED EROSION CONTROL MEASURES ARE IN PLACE.
- LIMIT ON-SITE CONSTRUCTION ROUTES AND STABILIZE CONSTRUCTION ENTRANCE(S). SEE DETAIL 2.
- THE APPLICANT SHALL SUBMIT A CONSTRUCTION BEST MANAGEMENT PRACTICES (BMPs) PROGRAM FOR REVIEW AND APPROVAL BY THE COUNTY PRIOR TO THE ISSUANCE OF ANY GRADING OR BUILDING PERMITS. THIS PROGRAM SHOULD ADDRESS CONSTRUCTION SITE CLEANUP AND CONTROL OF CONSTRUCTION DEBRIS. THE BMPs SHALL BE IMPLEMENTED BY THE GENERAL CONTRACTOR, SUBCONTRACTORS, AND SUPPLIERS OF MATERIAL AND EQUIPMENT. FAILURE TO COMPLY WITH THE APPROVED CONSTRUCTION BMPs WILL RESULT IN THE ISSUANCE OF CORRECTION NOTICES, CITATIONS, OR PROJECT STOP WORK ORDERS.
- THE APPLICANT SHALL GATHER ALL CONSTRUCTION DEBRIS ON A REGULAR BASIS AND PLACE THEM IN A DUMPSTER OR OTHER CONTAINER, WHICH IS EMPTIED OR REMOVED ON A WEEKLY BASIS. WHEN APPROPRIATE, TARPS SHALL BE USED ON THE GROUND TO COLLECT FALLEN DEBRIS OR SPLATTERS THAT COULD CONTRIBUTE TO STORM WATER POLLUTION.
- ALL DIRT, GRAVEL, RUBBISH, REFUSES AND GREEN WASTE FROM THE SIDEWALK, STREET PAVEMENT, AND STORM DRAINS ADJOINING THE PROJECT SITE SHALL BE REMOVED. DURING WET WEATHER, THE APPLICANT SHOULD AVOID DRIVING VEHICLES OFF PAVED AREAS AND OTHER OUTDOOR WORK.
- THE SIDEWALK AND PUBLIC STREET PAVEMENT ADJOINING THE PROJECT SITE SHALL BE BROOM SWEEPED ON A DAILY BASIS. CAKED ON MUD OR DIRT OR DIRT SHALL BE SCRAPED FROM THESE AREAS BEFORE SWEEPING.
- THE APPLICANT SHALL INSTALL FILTER MATERIALS (SUCH AS SANDBAGS, FILTER FABRIC, ETC.) AT THE STORM DRAIN INLET NEAREST THE DOWNSTREAM SIDE OF THE PROJECT SITE PRIOR TO: 1) START OF THE RAINY SEASON (OCTOBER 15), 2) SITE DEWATERING ACTIVITIES, OR 3) STREET WASHING ACTIVITIES, 4) SAW CUTTING ASPHALT OR CONCRETE, IN ORDER TO RETAIN ANY DEBRIS OR DIRT FLOWING INTO THE CITY STORM DRAIN SYSTEM. FILTER MATERIALS SHALL BE MAINTAINED AND/OR REPLACED AS NECESSARY TO ENSURE EFFECTIVENESS AND PREVENT STREET FLOODING. FILTERED PARTICLES SHALL BE DISPOSED OF IN THE TRASH.
- PROVIDE 2 FT. DEEP TEMPORARY SEDIMENT TRAPS AS SHOWN; SEE DETAIL 3/C-5.
- COVER STOCKPILED SOIL AND LANDSCAPING MATERIALS WITH SECURED PLASTIC SHEETING AND DIVERT RUNOFF AROUND THEM.
- ONCE GRADING IS COMPLETED, STABILIZE THE DISTURBED AREAS USING PERMANENT VEGETATION AS SOON AS POSSIBLE (HAND SEEDING).
- CONDUCT ROUTINE INSPECTIONS OF EROSION CONTROL MEASURES ESPECIALLY BEFORE AND IMMEDIATELY AFTER RAINSTORMS, AND REPAIR IF NECESSARY.
- PROTECT STORM DRAIN INLETS FROM SEDIMENT-LADEN RUNOFF. STORM DRAIN INLET PROTECTION DEVICES INCLUDE SAND BAG BARRIERS, FILTER FABRIC FENCES, BLOCK AND GRAVEL FILTERS, AND EXCAVATED DROP INLET SEDIMENT TRAPS.
- WHEN CLEANING SEDIMENTS FROM STREETS, DRIVEWAYS AND PAVED AREAS ON CONSTRUCTION SITES, USE DRY SWEEPING METHODS WHERE POSSIBLE. IF WATER MUST BE USED TO FLUSH PAVEMENT, COLLECT RUNOFF TO SETTLE OUT SEDIMENTS AND PROTECT STORM DRAIN INLETS.
- USE EROSION CONTROL BLANKETS FOR TEMPORARY SLOPE PROTECTION.

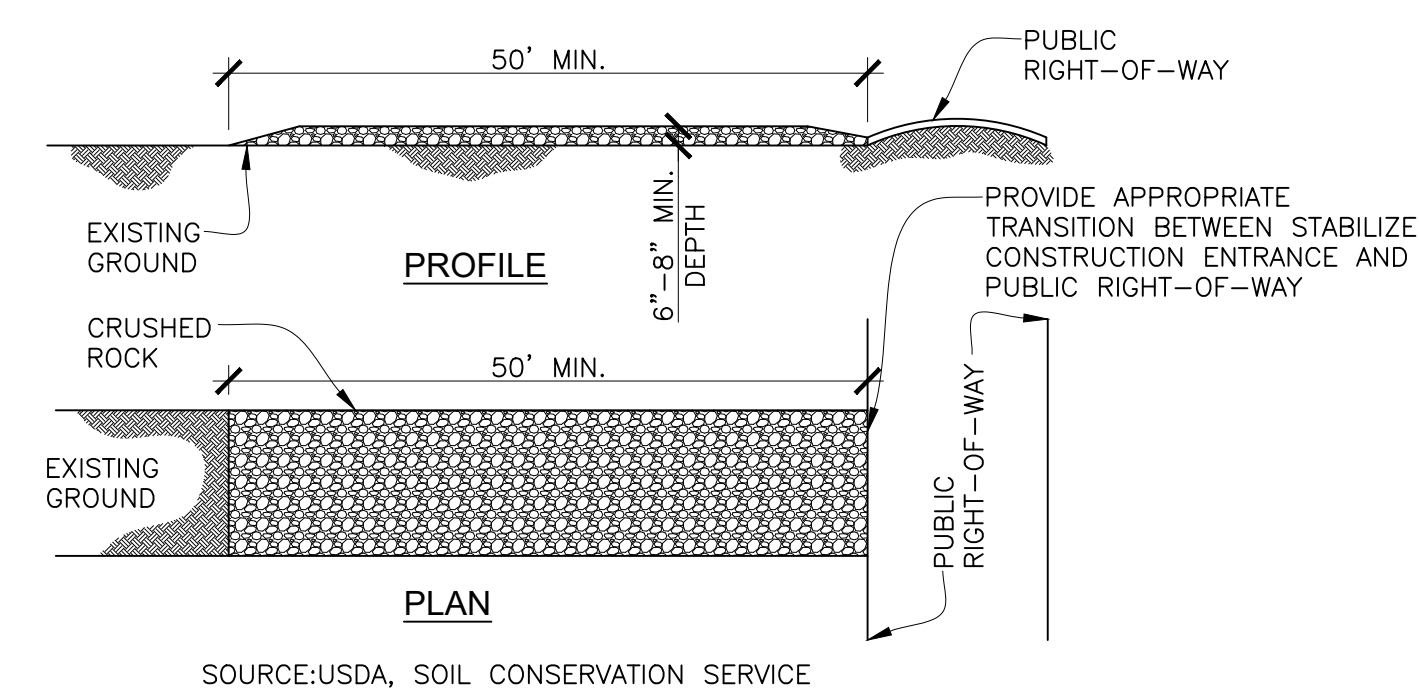

2 STABILIZED CONSTRUCTION ENTRANCE
 NOT TO SCALE

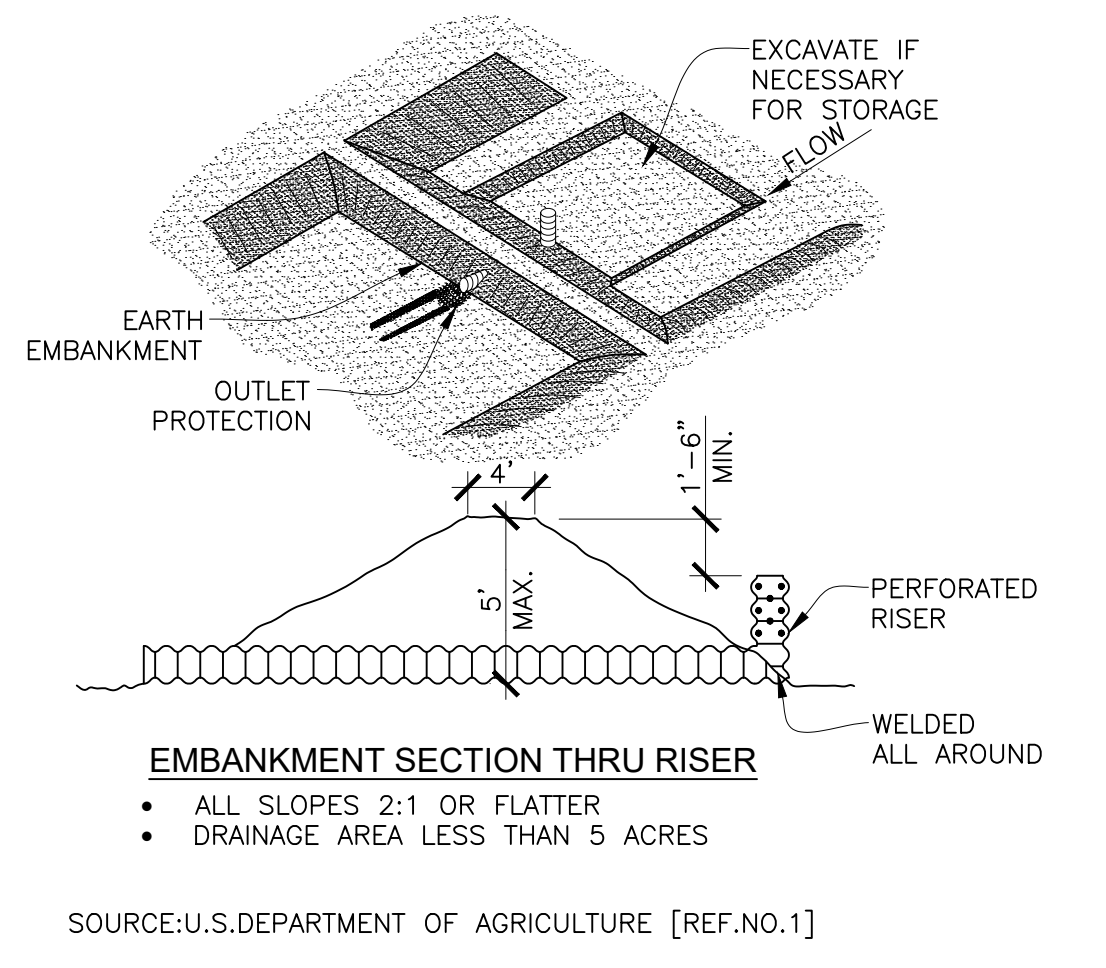

3 SEDIMENT TRAP
 NOT TO SCALE

LEGEND

	STABILIZED CONSTRUCTION ENTRANCE		STORM DRAIN OUTLET PROTECTION
	STRAW BALE DIKE		RIPRAP
	CONSTRUCTION FENCE		CHECK DAM
	DIKE		SUBSURFACE DRAIN
	UNLINED SWALE		SEEDING
	PAVED SWALE		STRAW MULCHING
	ROCK-LINED SWALE		HYDRAULIC SEEDING AND MULCHING
	UNLINED WATERWAY		PUNCHED STRAW
	GRASSED WATERWAY		LIMITS OF CLEARING AND GRADING
	PAVED WATERWAY		STRAW WATTLES
	ROCK-LINED WATERWAY		TREE PROTECTION FENCING (SEE ARBORIST REPORT)
	SEDIMENT TRAP		TREE PROTECTION ZONE (DETAIL BELOW)
	SEDIMENT BASIN		STORM DRAIN INLET PROTECTION WITH SANDBAGS AND FILTER FABRIC
	PIPE SLOPE DRAIN		TREE TO BE REMOVED
	PAVED FLUME		

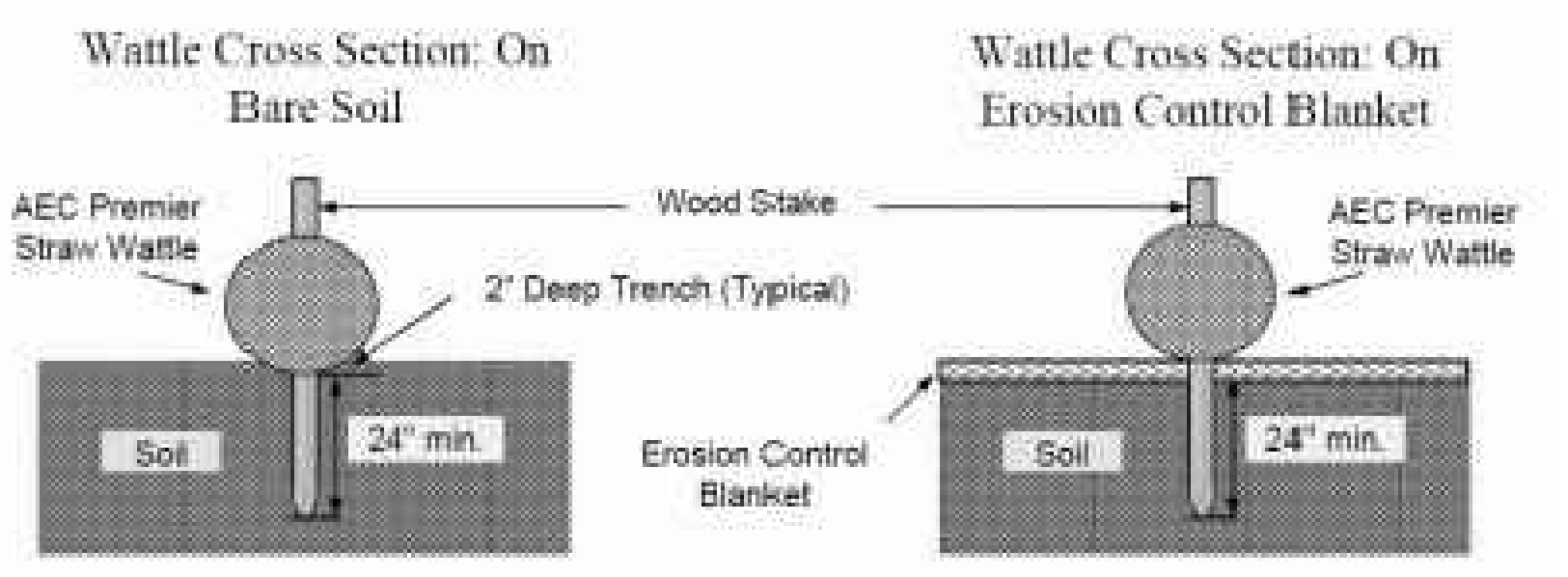

4 STRAW WATTLE SECTION
 NOT TO SCALE

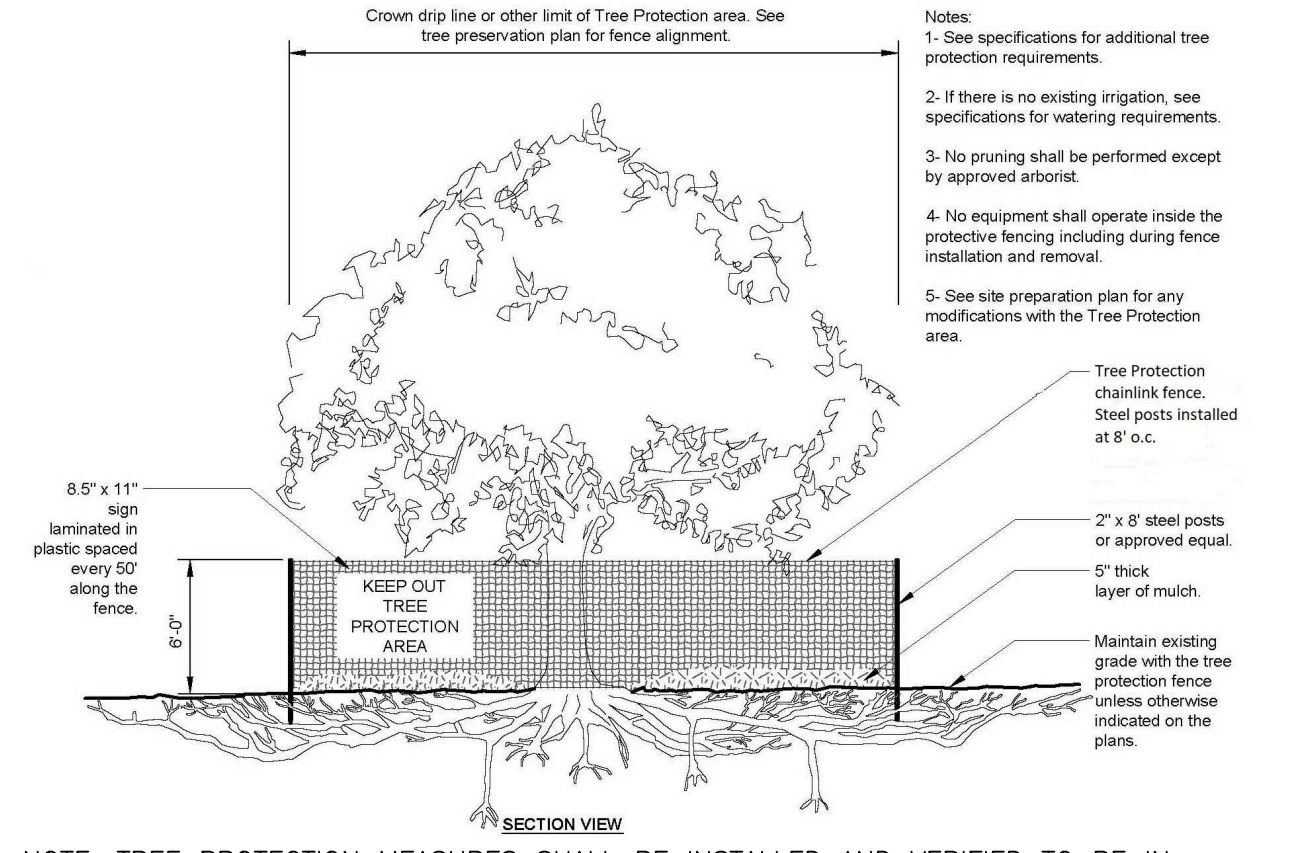

5 TEMPORARY TREE PROTECTION ZONE DETAIL
 NOT TO SCALE (SEE ARBORIST REPORT)

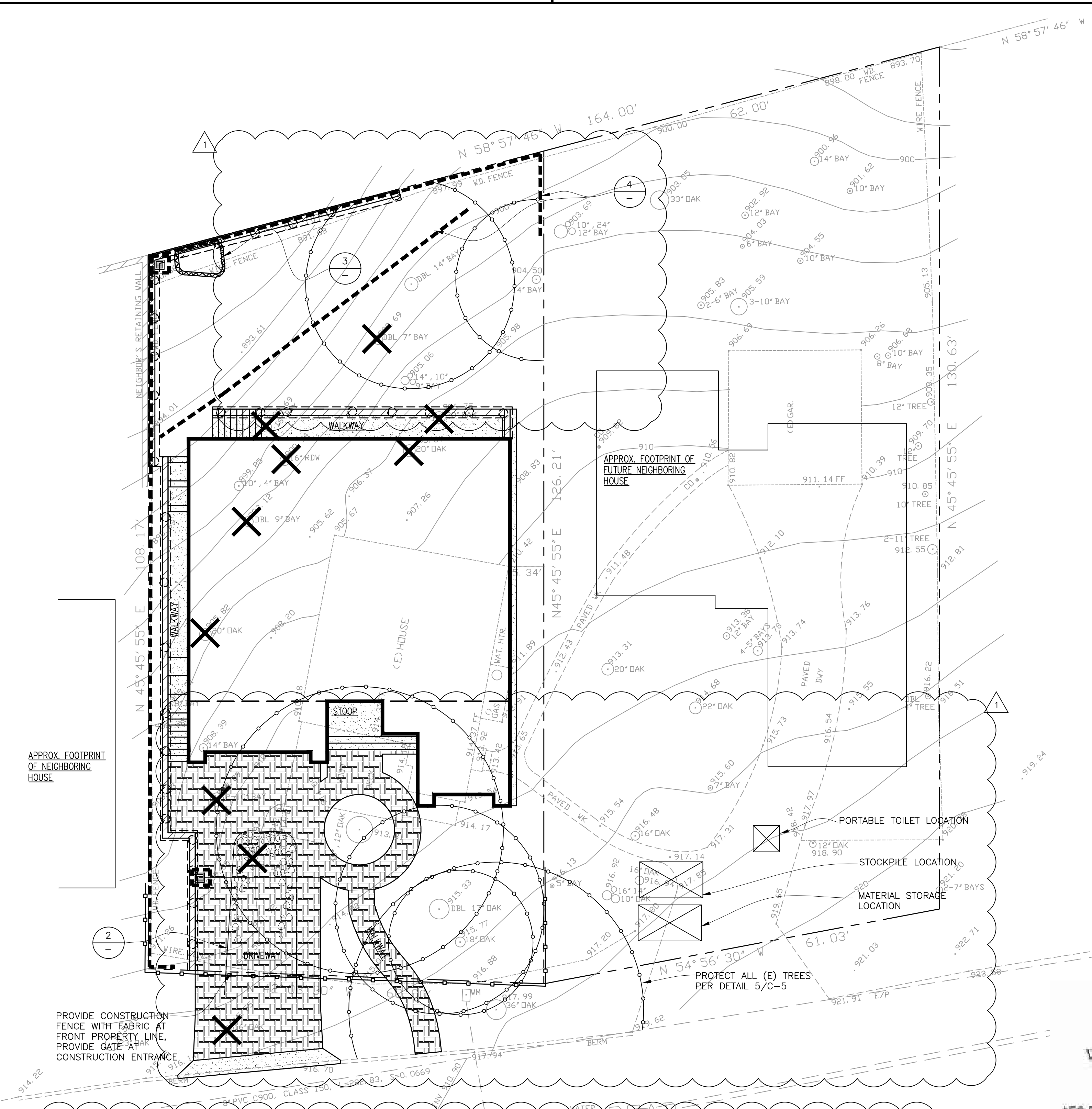

1 EROSION CONTROL PLAN
 SCALE: 1"=10'





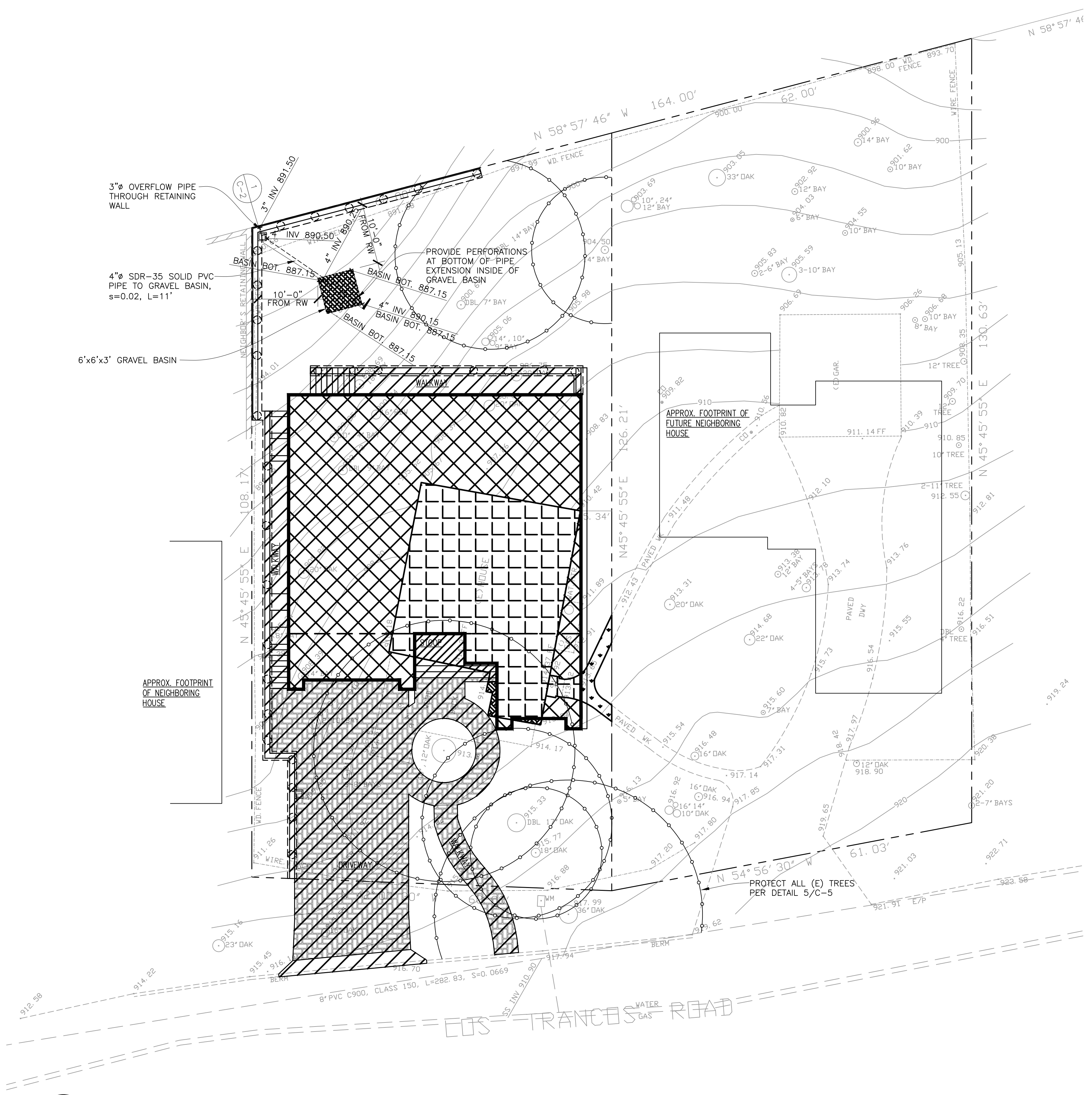

NOTES:

- OWNER OF THIS PROPERTY OWNS ALSO NEIGHBORING PROPERTY, THEREFORE STOCKPILE, MATERIAL STORAGE AND PORTABLE TOILET ARE LOCATED ON NEIGHBORING PROPERTY.
- ALL WORK WITHIN TREE PROTECTION ZONES SHOULD BE DONE WITH HAND TOOLS AND NO ROOTS CUT WITHIN TPZ GREATER THAN 2" IN DIAMETER.
- IF NEW UTILITY LINES ARE PROVIDED WITHIN TREE PROTECTION ZONES, HAND DIG OR PROVIDE DIRECTIONAL BORING.
- NO MORE THAN 25% OF THE TREE CANOPY CONFLICTING WITHIN THE NEW HOUSE SHALL BE PRUNED.





LEGEND

POST-PROJECT CREATED AREAS

-  PERVIOUS AREA
-  ROOF IMPERVIOUS AREA
-  FLAT IMPERVIOUS AREA
-  PERVIOUS AREA
-  ROOF IMPERVIOUS AREA
-  FLAT IMPERVIOUS AREA
-  GRAVEL BASIN

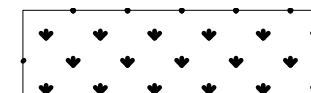
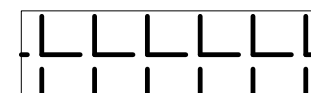
POST-PROJECT REPLACED AREAS

-  PERVIOUS AREA
-  ROOF IMPERVIOUS AREA
-  FLAT IMPERVIOUS AREA

IMPERV/PERV AREAS [SF]

PRE-PROJECT	
PERVIOUS AREA	6124
ROOF IMPERVIOUS AREA	847
FLAT IMPERVIOUS AREA	55
TOTAL LOT AREA	7026 SF

POST-PROJECT CREATED	
PERVIOUS AREA	47
ROOF IMPERVIOUS AREA	1530
FLAT IMPERVIOUS AREA	1625

POST-PROJECT REPLACED	
PERVIOUS AREA	810
FLAT IMPERVIOUS AREA	49

POST-PROJECT REMAIN	
PERVIOUS AREA	2965
ROOF IMPERVIOUS AREA	0
FLAT IMPERVIOUS AREA	0
TOTAL LOT AREA	7026 SF

NOTES

- DESIGN FIRE SPRINKLERS FOR DISCHARGE OF THE TEST WATER TO LANDSCAPE OR SANITARY SEWER.
- DRAIN CONDENSATE OF AIR CONDITIONING UNIT TO LANDSCAPING.
- DRAIN BOILER DRAIN LINES TO SANITARY SEWER.
- DRAIN ARCHITECTURAL COPPER RINSE WATER TO LANDSCAPING, DISCHARGE TO SANITARY SEWER.

1 SITE GRADING AND PAVING PLAN
SCALE: 1"=10'

Vit Hanacek Engineering
2912 Vessing Rd.
Pleasant Hill, CA 94523
Tel. (925) 262-7401
Fax. (925) 952-7812
vhanacek@yahoo.com



ISSUANCE AND REVISIONS:	NO.	DATE	DESCRIPTION
	1	01/12/2021	ARBORIST COMMENTS

NEW SINGLE FAMILY HOME
1061 LOS FRANCOS RD.
PORTOLA VALLEY, CA

PROJECT NAME:
STORMWATER MANAGEMENT PLAN

SHEET NO.:
C-6
PROJECT: 20-0654

C.3 and C.6 Development Review Checklist Municipal Regional Stormwater Permit (MRP) Stormwater Controls for Development Projects

Applicants: This form should be filled out by the Project Civil Engineer, if one is associated with the project.

Project Information

IA Enter Project Data (For "C.3 Regulated Projects," data will be reported in the municipality's stormwater Annual Report.)

Project Name: NEW SINGLE FAMILY HOME Case Number:

Project Address & Cross St.: 1061 LOS TRANCOS RD., PORTOLA VALLEY

Project APN: 080-084-320 Project Watershed: SAN FRANCISQUITO CREEK

Applicant Name: CRAIG AWBREY I.A.4 Slope on Site: 21 %

Applicant Phone: Applicant Email Address:

Development type: [X] Single Family Residential: A stand-alone home that is not part of a larger project.

[] Single Family Residential: Two or more lot residential development.1 # of units: _____

[] Multi-Family Residential # of units: _____

[] Commercial # of units: _____

[] Industrial, Manufacturing # of units: _____

[] Mixed-Use # of units: _____

[] Streets, Roads,2 etc.

[] Redevelopment3 as defined by MRP: creating, adding and/or replacing exterior existing impervious surface on a site where past development has occurred.

[] Special land use categories4 as defined by MRP: (1) auto service facilities, (2) retail gasoline outlets, (3) restaurants, (4) uncovered parking area (stand-alone or part of a larger project)

[] Institutions, schools, libraries, jails, etc.

[] Parks and trails, camp grounds, other recreational

[] Agricultural, wineries

[] Kennels, Ranches

[] Other, Please specify

Project Description5: DEMOLISH EXISTING SINGLE FAMILY HOME AND BUILD NEW SINGLE FAMILY HOME

I.A.2 Total Area of Site: 0.16 acres

I.A.3 Total Area of land disturbed during construction (include clearing, grading, excavating and stockpile area): 0.14 acres.

I.A.5 Certification: Name of person completing the form: VIT HANACEK Title: PROJECT ENGINEER

Phone number: 925-262-7401 Email address: V.HANACEK@YAHOO.COM

[X] By checking this box, I certify that the information provided on this form is correct and acknowledge that, should the project exceed the amount of new and/or replaced impervious surface provided in this form, the as-built project may be subject to additional improvements. Initials: VH Date: 10/19/2020

I have attached the following: [] Preliminary Calculations [] Final Calculations [X] A copy of site plan showing areas

1 Common Plans of Development (subdivisions or contiguous, commonly owned lots, for the construction of two or more homes developed within 1 year of each other) are not considered single family projects by the MRP.

2 Roadway projects creating 10,000 sq. ft. or more of contiguous impervious surface are subject to C.3 requirements if the roadway is new or being widened with additional traffic lanes.

3 See Standard Industrial Classification (SIC) codes here.

4 Project description examples: 5-story office building, industrial warehouse, residential with five 4-story buildings for 200 condominiums, etc.

Worksheet B C.3 and C.6 Development Review Checklist

C3 - Source Controls

Select appropriate source controls and identify the detail/plan sheet where these elements are shown.

Table with columns: Yes, Detail/Plan Sheet No., Features that require source control measures, Source Control Measures (Refer to Local Source Control List for detailed requirements).

1 Any connection to the sanitary sewer system is subject to sanitary district approval.

2 Businesses that may have outdoor process activities/equipment include machine shops, auto repair, industries with pretreatment facilities.

I.B Is the project a "C.3 Regulated Project" per MRP Provision C.3.b?

I.B.1 Enter the amount of impervious surface Retained, Replaced and/or Created by the project:

Table I.B.1 Impervious and Pervious Surfaces with columns I.B.1.a through I.B.1.e and rows for Impervious and Pervious Surface types.

I.B.2 Please review and attach additional worksheets as required below using the Total Impervious Surface (IS) Replaced and Created in cell I.B.1.f from Table I.B.1 above and enter the following:

Table I.B.2 with columns: Check all that apply, Check One Yes/No, Attach Worksheet.

5 For the MRP, pavement that meets the following definition of pervious pavement is NOT an impervious surface. Pervious pavement is defined as pavement that stores and infiltrates rainfall at a rate equal to immediately surrounding unpaved, landscaped areas, or that stores and infiltrates the rainfall runoff volume described in Provision C.3.

6 "Retained" means to leave existing impervious surfaces in place, unchanged; "Replaced" means to install new impervious surface where existing impervious surface is removed anywhere on the same property; and "Created" means the amount of new impervious surface being proposed which exceeds the total existing amount of impervious surface at the property.

7 Uncovered parking includes the top level of a parking structure.

Worksheet C C.3 and C.6 Development Review Checklist

Low Impact Development - Site Design Measures

Select Appropriate Site Design Measures (Required for C.3 Regulated Projects; all other projects are encouraged to implement site design measures, which may be required at municipal discretion.)

Projects that create and/or replace 2,500 - 10,000 sq. ft. of impervious surface, and stand-alone single family homes that create/replace 2,500 sq. ft. or more of impervious surface, must include one of Site Design Measures a through f (Provision C.3) requirements.

Larger projects must also include applicable Site Design Measures g through i. Consult with municipal staff about requirements for your project.

Select appropriate site design measures and identify the Plan Sheet where these elements are shown.

Table with columns: Yes, Plan Sheet Number, and list of site design measures a through i.

Regulated Projects can also consider the following site design measures to reduce treatment system sizing:

Table with columns: Yes, Plan Sheet Number, and list of measures j through l.

8 See MRP Provision C.3.a.i.(8) for non-C.3 Regulated Projects, C.3.c.i.(2)(a) for Regulated Projects, C.3.i for projects that create/replace 2,500 to 10,000 sq. ft. of impervious surface and stand-alone single family homes that create/replace 2,500 sq. ft. or more of impervious surface.

Worksheet A

C6 - Construction Stormwater BMPs

Include the following Construction BMPs on the Erosion Control Plan: (Applies to all projects with earthwork)

Table with columns: Yes, Plan Sheet, Best Management Practice (BMP) Notes.



Table with columns: ISSUANCE AND REVISIONS, NO., DATE, DESCRIPTION, PERMIT SET, ARBORIST COMMENTS.

NEW SINGLE FAMILY HOME 1061 LOS TRANCOS RD. PORTOLA VALLEY, CA

STORMWATER CONTROL CHECKLIST

SHEET NO.:

Construction Best Management Practices (BMPs)

Construction projects are required to implement the stormwater best management practices (BMP) on this page, as they apply to your project, all year long.

Materials & Waste Management

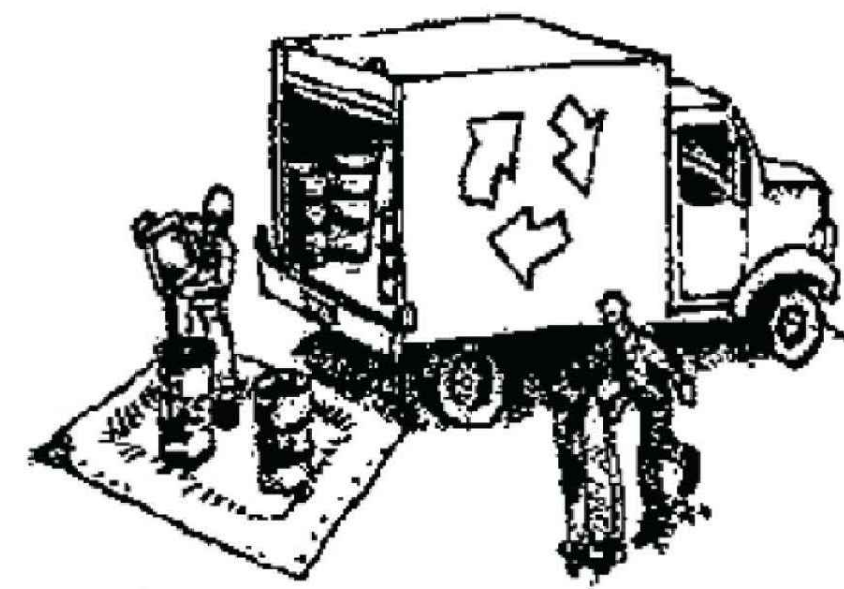

Non-Hazardous Materials

- Berm and cover stockpiles of sand, dirt or other construction material with tarps when rain is forecast or if not actively being used within 14 days.
- Use (but don't overuse) reclaimed water for dust control.

Hazardous Materials

- Label all hazardous materials and hazardous wastes (such as pesticides, paints, thinners, solvents, fuel, oil, and antifreeze) in accordance with city, county, state and federal regulations.
- Store hazardous materials and wastes in water tight containers, store in appropriate secondary containment, and cover them at the end of every work day or during wet weather or when rain is forecast.
- Follow manufacturer's application instructions for hazardous materials and be careful not to use more than necessary. Do not apply chemicals outdoors when rain is forecast within 24 hours.
- Arrange for appropriate disposal of all hazardous wastes.

Waste Management

- Cover waste disposal containers securely with tarps at the end of every work day and during wet weather.
- Check waste disposal containers frequently for leaks and to make sure they are not overfilled. Never hose down a dumpster on the construction site.
- Clean or replace portable toilets, and inspect them frequently for leaks and spills.
- Dispose of all wastes and debris properly. Recycle materials and wastes that can be recycled (such as asphalt, concrete, aggregate base materials, wood, gyp board, pipe, etc.)
- Dispose of liquid residues from paints, thinners, solvents, glues, and cleaning fluids as hazardous waste.

Construction Entrances and Perimeter

- Establish and maintain effective perimeter controls and stabilize all construction entrances and exits to sufficiently control erosion and sediment discharges from site and tracking off site.
- Sweep or vacuum any street tracking immediately and secure sediment source to prevent further tracking. Never hose down streets to clean up tracking.

Equipment Management & Spill Control



Maintenance and Parking

- Designate an area, fitted with appropriate BMPs, for vehicle and equipment parking and storage.
- Perform major maintenance, repair jobs, and vehicle and equipment washing off site.
- If refueling or vehicle maintenance must be done onsite, work in a bermed area away from storm drains and over a drip pan or drop cloths big enough to collect fluids. Recycle or dispose of fluids as hazardous waste.
- If vehicle or equipment cleaning must be done onsite, clean with water only in a bermed area that will not allow rinse water to run into gutters, streets, storm drains, or surface waters.
- Do not clean vehicle or equipment onsite using soaps, solvents, degreasers, or steam cleaning equipment.

Spill Prevention and Control

- Keep spill cleanup materials (e.g., rags, absorbents and cat litter) available at the construction site at all times.
- Inspect vehicles and equipment frequently for and repair leaks promptly. Use drip pans to catch leaks until repairs are made.
- Clean up spills or leaks immediately and dispose of cleanup materials properly.
- Do not hose down surfaces where fluids have spilled. Use dry cleanup methods (absorbent materials, cat litter, and/or rags).
- Sweep up spilled dry materials immediately. Do not try to wash them away with water, or bury them.
- Clean up spills on dirt areas by digging up and properly disposing of contaminated soil.
- Report significant spills immediately. You are required by law to report all significant releases of hazardous materials, including oil. To report a spill: 1) Dial 911 or your local emergency response number, 2) Call the Governor's Office of Emergency Services Warning Center, (800) 852-7550 (24 hours).

Earthmoving



- Schedule grading and excavation work during dry weather.
- Stabilize all denuded areas, install and maintain temporary erosion controls (such as erosion control fabric or bonded fiber matrix) until vegetation is established.
- Remove existing vegetation only when absolutely necessary, and seed or plant vegetation for erosion control on slopes or where construction is not immediately planned.
- Prevent sediment from migrating offsite and protect storm drain inlets, gutters, ditches, and drainage courses by installing and maintaining appropriate BMPs, such as fiber rolls, silt fences, sediment basins, gravel bags, berms, etc.
- Keep excavated soil on site and transfer it to dump trucks on site, not in the streets.

Contaminated Soils

- If any of the following conditions are observed, test for contamination and contact the Regional Water Quality Control Board:
 - Unusual soil conditions, discoloration, or odor.
 - Abandoned underground tanks.
 - Abandoned wells
 - Buried barrels, debris, or trash.

Paving/Asphalt Work



- Avoid paving and seal coating in wet weather or when rain is forecast, to prevent materials that have not cured from contacting stormwater runoff.
- Cover storm drain inlets and manholes when applying seal coat, tack coat, slurry seal, fog seal, etc.
- Collect and recycle or appropriately dispose of excess abrasive gravel or sand. Do NOT sweep or wash it into gutters.
- Do not use water to wash down fresh asphalt concrete pavement.

Sawcutting & Asphalt/Concrete Removal

- Protect nearby storm drain inlets when saw cutting. Use filter fabric, catch basin inlet filters, or gravel bags to keep slurry out of the storm drain system.
- Shovel, absorb, or vacuum saw-cut slurry and dispose of all waste as soon as you are finished in one location or at the end of each work day (whichever is sooner!).
- If sawcut slurry enters a catch basin, clean it up immediately.

Concrete, Grout & Mortar Application



- Store concrete, grout, and mortar away from storm drains or waterways, and on pallets under cover to protect them from rain, runoff, and wind.
- Wash out concrete equipment/trucks offsite or in a designated washout area, where the water will flow into a temporary waste pit, and in a manner that will prevent leaching into the underlying soil or onto surrounding areas. Let concrete harden and dispose of as garbage.
- When washing exposed aggregate, prevent washwater from entering storm drains. Block any inlets and vacuum gutters, hose washwater onto dirt areas, or drain onto a bermed surface to be pumped and disposed of properly.

Landscaping

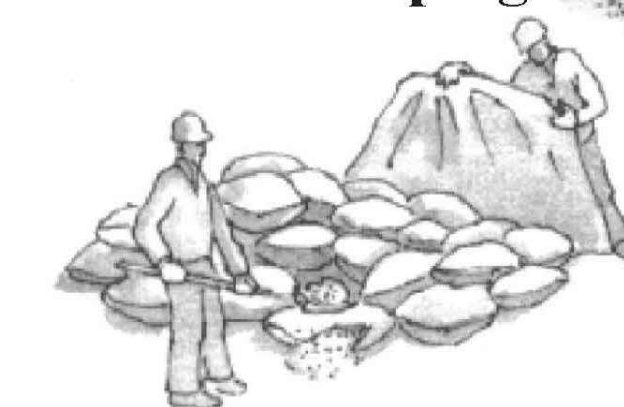

- Protect stockpiled landscaping materials from wind and rain by storing them under tarps all year-round.
- Stack bagged material on pallets and under cover.
- Discontinue application of any erodible landscape material within 2 days before a forecast rain event or during wet weather.

Painting & Paint Removal

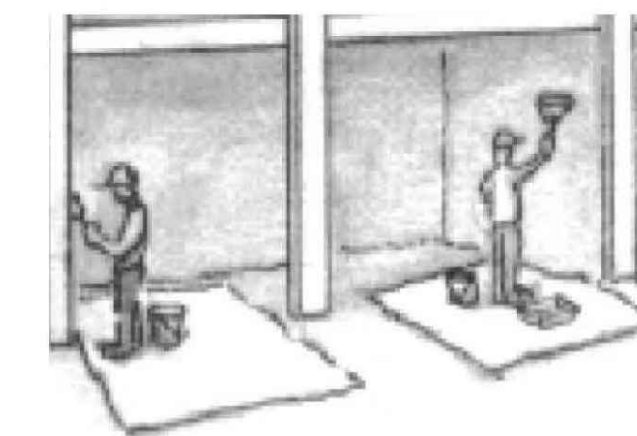

Painting Cleanup and Removal

- Never clean brushes or rinse paint containers into a street, gutter, storm drain, or stream.
- For water-based paints, paint out brushes to the extent possible, and rinse into a drain that goes to the sanitary sewer. Never pour paint down a storm drain.
- For oil-based paints, paint out brushes to the extent possible and clean with thinner or solvent in a proper container. Filter and reuse thinners and solvents. Dispose of excess liquids as hazardous waste.
- Paint chips and dust from non-hazardous dry stripping and sand blasting may be swept up or collected in plastic drop cloths and disposed of as trash.
- Chemical paint stripping residue and chips and dust from marine paints or paints containing lead, mercury, or tributyltin must be disposed of as hazardous waste. Lead based paint removal requires a state-certified contractor.

Dewatering

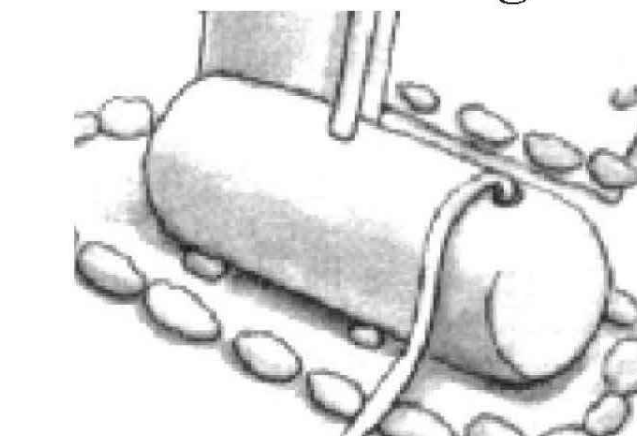

- Discharges of groundwater or captured runoff from dewatering operations must be properly managed and disposed. When possible send dewatering discharge to landscaped area or sanitary sewer. If discharging to the sanitary sewer call your local wastewater treatment plant.
- Divert run-on water from offsite away from all disturbed areas.
- When dewatering, notify and obtain approval from the local municipality before discharging water to a street gutter or storm drain. Filtration or diversion through a basin, tank, or sediment trap may be required.
- In areas of known or suspected contamination, call your local agency to determine whether the ground water must be tested. Pumped groundwater may need to be collected and hauled off-site for treatment and proper disposal.

Storm drain polluters may be liable for fines of up to \$10,000 per day!

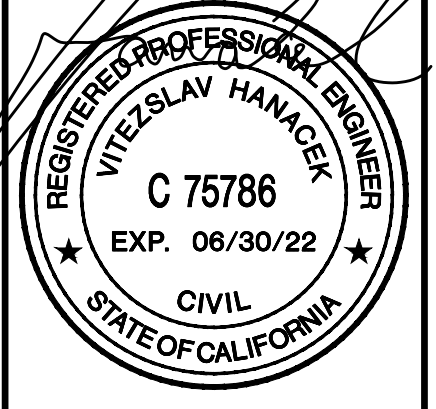

ISSUANCE AND REVISIONS:	NO.	DATE	DESCRIPTION
	1	01/12/2021	PERMIT SET
			ARBORIST COMMENTS

NEW SINGLE FAMILY HOME
1061 LOS TRANCOS RD.
PORTOLA VALLEY, CA

SAN MATEO COUNTYWIDE BMPs



County of San Mateo - Planning and Building Department

ATTACHMENT D

Advanced Tree Care

965 East San Carlos Ave, San Carlos

1061 Los Trancos Rd., Portola Valley

June 30, 2020

Craig Awbrey
Awbrey Development Co., Inc
85 Saratoga Ave., Suite 103
Santa Clara, CA 95051

Site: 1061 Los Trancos Rd., Portola Valley

Dear Craig,

At your request I visited the above site for the purpose of inspecting and commenting on the regulated trees around the property. A new home is planned, prompting the need for this tree protection report.

Method:

San Mateo County regulates Significant Trees whereby a "SIGNIFICANT TREE" shall mean any live woody plant rising above the ground with a single stem or trunk of a circumference of 38" (Diameter 12.1") or more measured at 4 1/2' vertically above the ground or immediately below the lowest branch, whichever is lower, and having the inherent capacity of naturally producing one main axis continuing to grow more vigorously than the lateral axes.

The location of the Significant trees on this site can be found on the plan provided by you. Each tree is given an identification number. The trees are measured at 54 inches above ground level (DBH or Diameter at Breast Height). A condition rating of 1 to 100 is assigned to each tree representing form and vitality on the following scale:

1 to 29	Very Poor
30 to 49	Poor
50 to 69	Fair
70 to 89	Good
90 to 100	Excellent

The height and spread of each tree is estimated. A Comments section is provided for any significant observations affecting the condition rating of the tree.

A Summary and Tree Protection Plan are at the end of the survey providing recommendations for maintaining the health and condition of the trees during and after construction.

If you have any questions, please don't hesitate to call.

Sincerely



Robert Weatherill
Certified Arborist WE 1936A

Tree Survey

Tree#	Species	DBH	Ht/Sp	Con Rating	Comments
1	Valley oak <i>Quercus lobata</i>	28.8"	60/50	60	Good health, fair condition, side pruned for utility, Significant
2	Valley oak <i>Quercus lobata</i>	16.3"	30/20	60	Good health, fair condition Significant
3	Valley oak <i>Quercus lobata</i>	14.9"	50/20	55	Fair health and condition Significant
4	Coast live oak <i>Quercus agrifolia</i>	15.5"/15.1"	30/20	55	Fair health and condition, codominant at 1', cabled, Significant
5	Valley oak <i>Quercus lobata</i>	35.0"	60/50	65	Good health and condition, codominant at 6', Significant
6	California bay <i>Umbellularia californica</i>	8.4/6.7/7.7"	30/20	50	Fair health and condition, codominant at 2', Significant
7	California bay <i>Umbellularia californica</i>	8.0/10.6"	40/20	55	Fair health and condition, codominant at grade, Significant
8	Black oak <i>Quercus kelloggii</i>	18.2"	50/20	50	Fair health and condition, heavily pruned over neighbor's at 50', Significant
9	California bay <i>Umbellularia californica</i>	7.7/10.1"	40/20	50	Fair health and condition, codominant at grade, Significant
10	Incense cedar <i>Calocedrus decurrens</i>	14.7"	40/10	40	Poor health, fair condition, suppressed by adjacent trees, Significant
11	California bay <i>Umbellularia californica</i>	15.7"	50/20	60	Good health and condition Significant
12	Black oak <i>Quercus kelloggii</i>	22.1"	50/30	40	Fair health, poor condition, cavity and broken top, Significant
13	Black oak <i>Quercus kelloggii</i>	20.0"	40/40	40	Fair health, poor condition, significant lean, Significant
14	California bay <i>Umbellularia californica</i>	12.2"/7.3"/8.0"	40/20	40	Fair health, poor condition, leaning on #12, Significant
15	California bay <i>Umbellularia californica</i>	12.3/8.1"	40/20	60	Good health and condition, codominant at 2', Significant
16	California bay <i>Umbellularia californica</i>	13.5"	35/20	50	Fair health and condition, significant lean, Significant

Summary:

The trees on the site are all natives in varying health and condition.

There are 16 Significant trees on the property.

Tree # 10 is an incense cedar in poor health and fair condition, it has been suppressed by the adjacent surrounding trees. I recommend that this tree be removed.

Tree # 12 is a black oak in fair health but poor condition. There is a cavity in the trunk and the top of the tree has previously broken out. I recommend this tree be removed.

Tree # 13 is a black oak with a significant lean due to being suppressed by the adjacent surrounding trees. I recommend this tree be removed.

Tree # 14 is a multi-stemmed bay in fair health and poor condition. This tree is leaning on Tree # 12.

Tree #s 2, 6, 7, 8, 9, and 11 are smaller trees but still Significant and have also been requested for removal.

Tree #s 1, 3, 4, 5, 15 and 16 are Significant trees and should be protected during construction.

Tree Protection Plan

1. The Tree Protection Zone (TPZ) should be defined with protective fencing. This should be cyclone or chain link fencing on 1 1/2" or 2" posts driven at least 2 feet in to the ground standing at least 6 feet tall. Normally a TPZ is defined by the dripline of the tree. I recommend the TPZ's as follows:-

Tree # 1: TPZ should be at 20 feet from the trunk closing on the property line in accordance with Type I Tree Protection as outlined and illustrated in image 2.15-1 and 2 ⁽⁶⁾.

The walk way through the TPZ should be constructed by hand with no roots greater than 2" in diameter cut without Arborist Supervision.

Tree # 3: TPZ should be at 10 feet from the trunk in accordance with Type I Tree Protection as outlined and illustrated in image 2.15-1 and 2 ⁽⁶⁾.

The walk way through the TPZ should be constructed by hand with no roots greater than 2" in diameter cut without Arborist Supervision.

Tree # 4: TPZ should be at 15 feet radius from the trunk of the tree in accordance with Type I Tree Protection as outlined and illustrated in image 2.15-1 and 2 ⁽⁶⁾.

The walk way through the TPZ should be constructed by hand with no roots greater than 2" in diameter cut without Arborist Supervision.

Tree # 5: TPZ should be at 20 feet radius from the trunk of the tree in accordance with Type I Tree Protection as outlined and illustrated in image 2.15-1 and 2 ⁽⁶⁾. This can be reduced to no less than 10 feet to accommodate new construction. Basement excavation should be supported with stitch piers such that there is no unnecessary over dig.

Demolition of the existing home should be done by hand within the TPZ. If machinery is to track through the TPZ the root zone should be protected with a buffer of plywood laid on 4" of wood chip.

The walk way through the TPZ should be constructed by hand with no roots greater than 2" in diameter cut without Arborist Supervision.

Tree # 15: TPZ should be at 15 feet radius from the trunk of the tree in accordance with Type I Tree Protection as outlined and illustrated in image 2.15-1 and 2 ⁽⁶⁾.

Tree # 16: TPZ should be at 10 feet from the trunk of the tree closing on the property line in accordance with Type I Tree Protection as outlined and illustrated in image 2.15-1 and 2 ⁽⁶⁾.



IMAGE 2.15-1
Tree Protection Fence at the Dripline

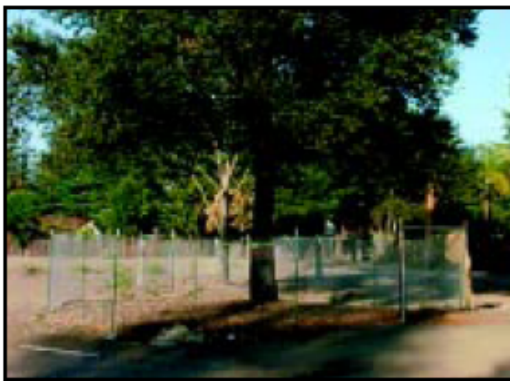

IMAGE 2.15-2
Tree Protection Fence at the Dripline

• **Type I Tree Protection**

The fences shall enclose the entire area under the **canopy dripline or TPZ** of the tree(s) to be saved throughout the life of the project, or until final improvement work within the area is required, typically near the end of the project (*see Images 2.15-1 and 2.15-2*). Parking Areas: If the fencing must be located on paving or sidewalk that will not be demolished, the posts may be supported by an appropriate grade level concrete base.

2. Any pruning and maintenance of the tree shall be carried out before construction begins. This should allow for any clearance requirements for both the new structure and any construction machinery. This will eliminate the possibility of damage during construction. **The pruning should be carried out by an arborist, not by construction personnel.** No limbs greater than 4" in diameter shall be removed.
3. Any excavation in ground where there is a potential to damage roots of 1" or more in diameter should be carefully hand dug. Where possible, roots should be dug around rather than cut.⁽²⁾
4. If roots are broken, every effort should be made to remove the damaged area and cut it back to its closest lateral root. A clean cut should be made with a saw or pruners. This will prevent any infection from damaged roots spreading throughout the root system and into the tree.⁽²⁾

5. Do Not:⁽⁴⁾

- a. Allow run off or spillage of damaging materials into the area below any tree canopy.
 - b. Store materials, stockpile soil, park or drive vehicles within the TPZ of the tree.
 - c. Cut, break, skin or bruise roots, branches or trunk without first obtaining permission from the city arborist.
 - d. Allow fires under any adjacent trees.
 - e. Discharge exhaust into foliage.
 - f. Secure cable, chain or rope to trees or shrubs.
 - g. Apply soil sterilants under pavement near existing trees.
6. Where roots are exposed, they should be kept covered with the native soil or four layers of wetted, untreated burlap. Roots will dry out and die if left exposed to the air for too long.⁽⁴⁾
7. Route pipes into alternate locations to avoid conflict with roots.⁽⁴⁾
8. Where it is not possible to reroute pipes or trenches, the contractor is to bore beneath the dripline of the tree. The boring shall take place no less than 3 feet below the surface of the soil in order to avoid encountering “feeder” roots.⁽⁴⁾
9. Compaction of the soil within the dripline shall be kept to a minimum.⁽²⁾ If access is required to go through the TPZ of a protected tree, the area within the TPZ should be protected from compaction either with steel plates or with 4” of wood chip overlaid with plywood.
10. Any damage due to construction activities shall be reported to the project arborist or city arborist within 6 hours so that remedial action can be taken.
11. Ensure upon completion of the project that the original ground level is restored

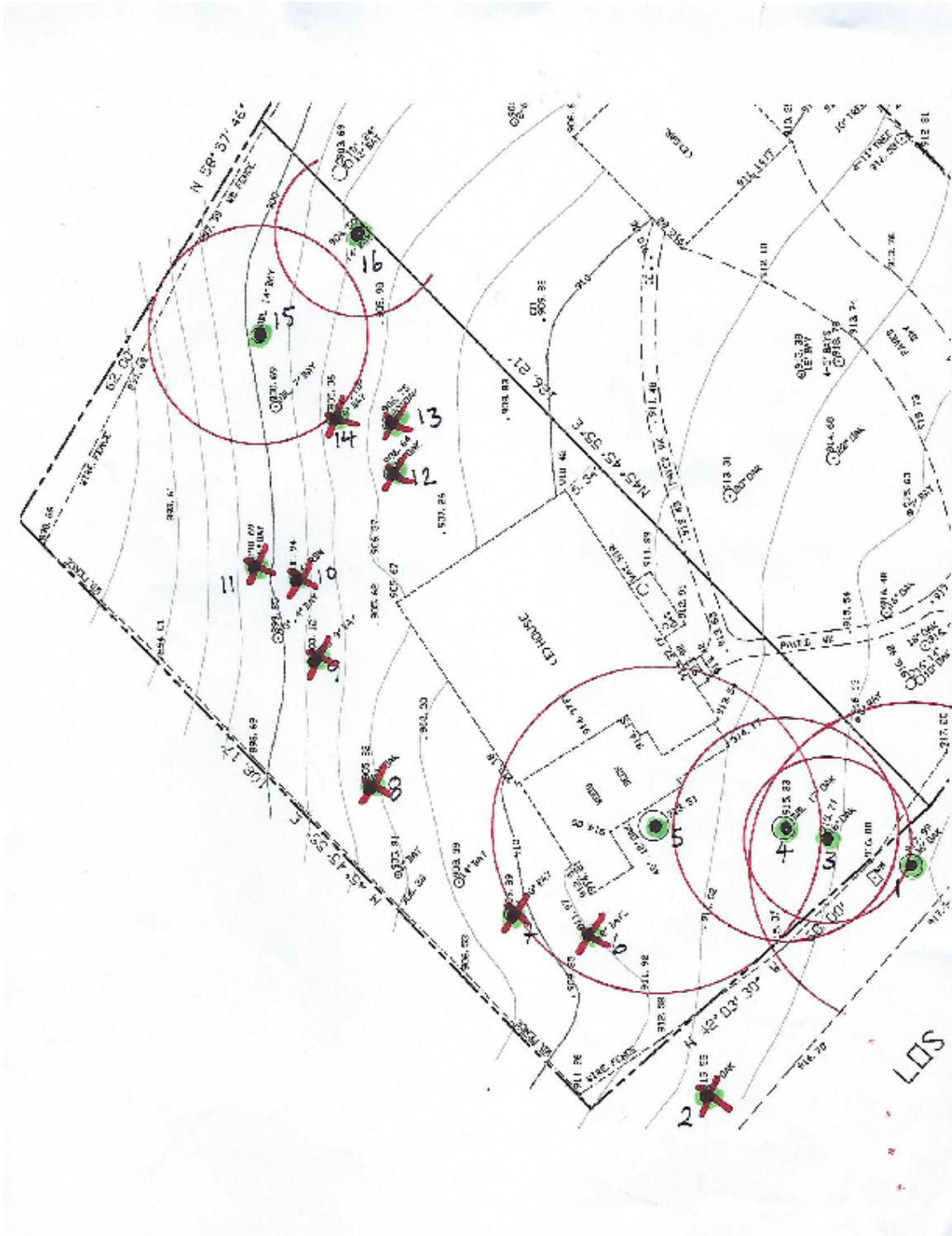

Location of existing house, Significant trees and their Tree Protection Zones
And proposed tree removals

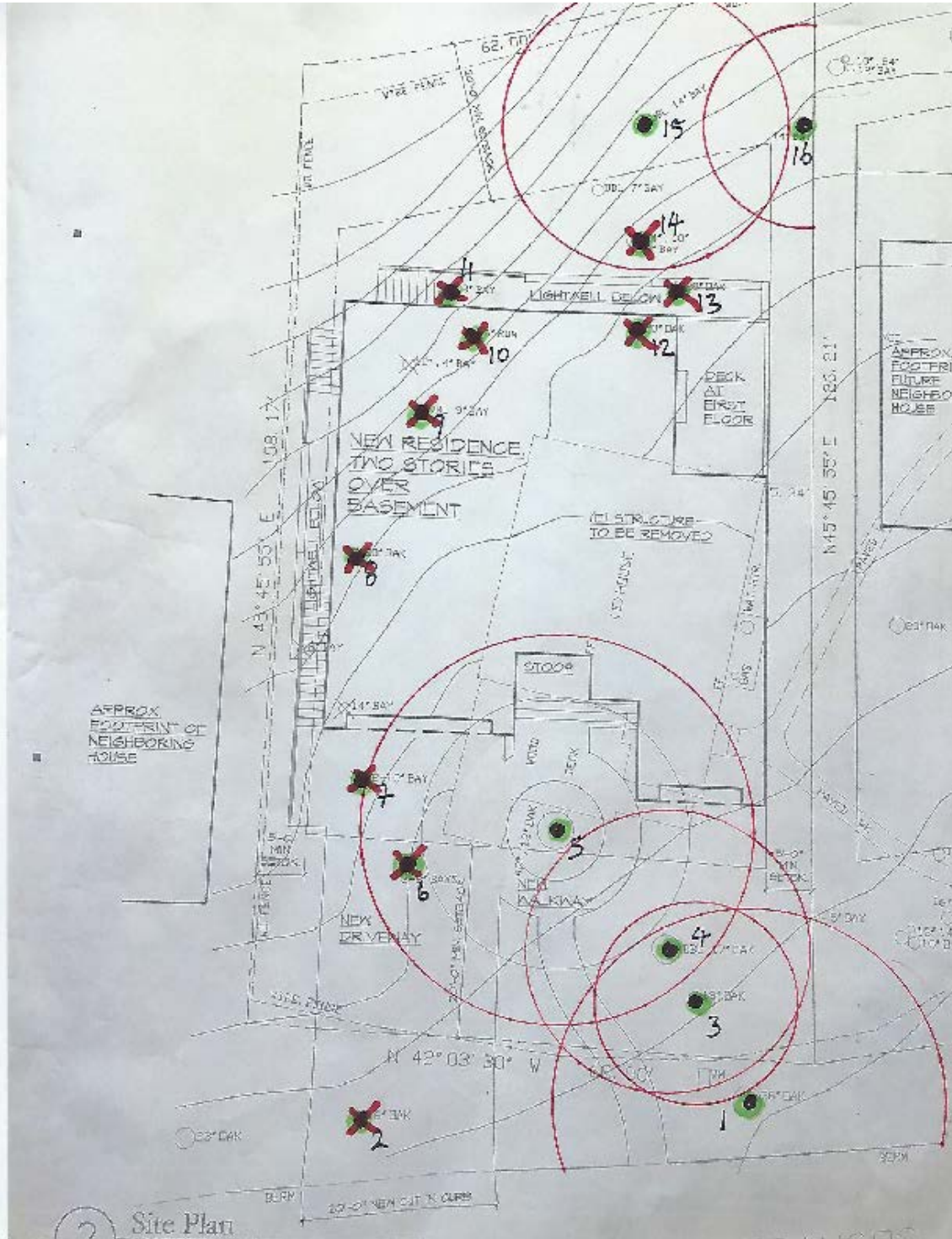

Location of proposed new construction, Significant trees and their Tree Protection Zones
And proposed removals

Glossary

Canopy	The part of the crown composed of leaves and small twigs. ⁽²⁾
Cavities	An open wound, characterized by the presence of extensive decay and resulting in a hollow. ⁽¹⁾
Decay	Process of degradation of woody tissues by fungi and bacteria through the decomposition of cellulose and lignin ⁽¹⁾
Dripline	The width of the crown as measured by the lateral extent of the foliage. ⁽¹⁾
Genus	A classification of plants showing similar characteristics.
Root plate	The point at which the trunk flares out at the base of the tree to become the root system.
Species	A Classification that identifies a particular plant.
Standard height	Height at which the girth of the tree is measured. Typically 4 1/2 feet above ground level

References

(1) Matheny, N.P., and Clark, J.P. Evaluation of Hazard Trees in Urban Areas. International Society of Arboriculture, 1994.

(2) Harris, R.W., Matheny, N.P. and Clark, J.R.. Arboriculture: Integrated Management of Landscape Trees, Shrubs and Vines. Prentice Hall, 1999.

(3) Carlson, Russell E. Paulownia on The Green: An Assessment of Tree Health and Structural Condition. Tree Tech Consulting, 1998.

(4) Extracted from a copy of Tree Protection guidelines. Anon

(5) T. D. Sydnor, Arboricultural Glossary. School of Natural Resources, 2000

(6) D Dockter, Tree Technical Manual. City of Palo Alto, June, 2001

Certification of Performance⁽³⁾

I, Robert Weatherill certify:

- * That I have personally inspected the tree(s) and/or the property referred to in this report, and have stated my findings accurately. The extent of the evaluation and appraisal is stated in the attached report and the Terms and Conditions;
- * That I have no current or prospective interest in the vegetation or the property that is the subject of this report, and I have no personal interest or bias with respect to the parties involved;
- * That the analysis, opinions and conclusions stated herein are my own, and are based on current scientific procedures and facts;
- * That my compensation is not contingent upon the reporting of a predetermined conclusion that favors the cause of the client or any other party, nor upon the results of the assessment, the attainment of stipulated results, or the occurrence of any subsequent events;
- * That my analysis, opinions, and conclusions were developed and this report has been prepared according to commonly accepted Arboricultural practices;
- * That no one provided significant professional assistance to the consultant, except as indicated within the report.

I further certify that I am a member of the International Society of Arboriculture and a Certified Arborist. I have been involved in the practice of arboriculture and the care and study of trees for over 20 years.

Signed



Robert Weatherill
Certified Arborist WE 1936a
Date: 7/3/20

Terms and Conditions(3)

The following terms and conditions apply to all oral and written reports and correspondence pertaining to consultations, inspections and activities of Advanced Tree Care :

1. All property lines and ownership of property, trees, and landscape plants and fixtures are assumed to be accurate and reliable as presented and described to the consultant, either verbally or in writing. The consultant assumes no responsibility for verification of ownership or locations of property lines, or for results of any actions or recommendations based on inaccurate information.
2. It is assumed that any property referred to in any report or in conjunction with any services performed by Advanced Tree Care, is not in violation of any applicable codes, ordinances, statutes, or other governmental regulations, and that any titles and ownership to any property are assumed to be good and marketable. Any existing liens and encumbrances have been disregarded.
3. All reports and other correspondence are confidential, and are the property of Advanced Tree Care and its named clients and their assignees or agents. Possession of this report or a copy thereof does not imply any right of publication or use for any purpose, without the express permission of the consultant and the client to whom the report was issued. Loss, removal or alteration of any part of a report invalidates the entire appraisal/evaluation.
4. The scope of any report or other correspondence is limited to the trees and conditions specifically mentioned in those reports and correspondence. Advanced Tree Care and the consultant assume no liability for the failure of trees or parts of trees, either inspected or otherwise. The consultant assumes no responsibility to report on the condition of any tree or landscape feature not specifically requested by the named client.
5. All inspections are limited to visual examination of accessible parts, without dissection, excavation, probing, boring or other invasive procedures, unless otherwise noted in the report. No warrantee or guarantee is made, expressed or implied, that problems or deficiencies of the plants or the property will not occur in the future, from any cause. The consultant shall not be responsible for damages caused by any tree defects, and assumes no responsibility for the correction of defects or tree related problems.
6. The consultant shall not be required to provide further documentation, give testimony, be deposed, or attend court by reason of this appraisal/report unless subsequent contractual arrangements are made, including payment of additional fees for such services as described by the consultant or in the fee schedules or contract.
7. Advanced Tree Care has no warrantee, either expressed or implied, as to the suitability of the information contained in the reports for any purpose. It remains the responsibility of the client to determine applicability to his/her particular case.
8. Any report and the values, observations, and recommendations expressed therein represent the professional opinion of the consultants, and the fee for services is in no manner contingent upon the reporting of a specified value nor upon any particular finding to be reported.
9. Any photographs, diagrams, graphs, sketches, or other graphic material included in any report, being intended solely as visual aids, are not necessarily to scale and should not be construed as engineering reports or surveys, unless otherwise noted in the report. Any reproductions of graphs material or the work product of any other persons is intended solely for the purpose of clarification and ease of reference. Inclusion of said information does not constitute a representation by Advanced Tree Care or the consultant as to the sufficiency or accuracy of that information.



County of San Mateo - Planning and Building Department

ATTACHMENT E



GEOLOGIC EVALUATION AND GEOTECHNICAL INVESTIGATION

2-LOT DEVELOPMENT
1061 LOS TRANCOS ROAD
PORTOLA VALLEY, CALIFORNIA

Prepared for
Mr. Craig Awbrey
85 Saratoga Avenue
Santa Clara, California 95051

June 2020
Project No. 5082-1



June 25, 2020
5082-1

Mr. Craig Awbrey
85 Saratoga Avenue, Suite 103
Santa Clara, California 95051

**RE: GEOLOGIC AND GEOTECHNICAL
INVESTIGATION
TWO-LOT DEVELOPMENT
1061 LOS TRANCOS ROAD
PORTOLA VALLEY, CALIFORNIA**

Dear Mr. Awbrey:

As requested, we have performed a geologic and geotechnical investigation for your proposed two-lot development at 1061 Los Trancos Road in Los Trancos Woods, an unincorporated area of San Mateo County near Portola Valley, California. In particular, we have evaluated the potential for ground surface rupture by the San Andreas Fault, which is considered to be active by the State of California and San Mateo County, and is mapped as being in the near vicinity of your property. We did not encounter fault traces or indications of faulting within our excavated fault trench or exploratory borings and have concluded that the potential for ground surface fault rupture by active faulting within the potential building areas is low. The accompanying report summarizes the results of our field exploration, fault trenching, laboratory testing, engineering analysis, and presents our geotechnical recommendations for the proposed residences.

We refer you to the text of our report for specific recommendations.

Thank you for the opportunity to work with you on this project. If you have any questions or comments about our findings or recommendations, please call.

Very truly yours,

ROMIG ENGINEERS, INC.

Alexander Shmurakov, G.I.T

David F. Hoexter,

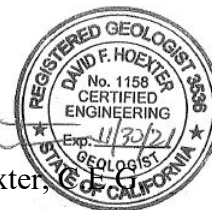

Lucas J. Ottoboni,



Glenn A. Romig,



Copies: Addressee (via email)
Beausoleil Architects (via email)
Attn: Mr. Bob Boles

**GEOLOGIC AND GEOTECHNICAL INVESTIGATION
AWBREY TWO LOT DEVELOPMENT
1061 LOS TRANCOS ROAD
PORTOLA VALLEY, CALIFORNIA 94028**

**PREPARED FOR:
MR. CRAIG AWBREY
85 SARATOGA AVENUE, SUITE 103
SANTA CLARA, CALIFORNIA 95051**

**PREPARED BY:
ROMIG ENGINEERS, INC.
1390 EL CAMINO REAL, SECOND FLOOR
SAN CARLOS, CALIFORNIA 94070**

JUNE 2020



TABLE OF CONTENTS

Page No.

Letter of transmittal	
Cover Page	
TABLE OF CONTENTS	
INTRODUCTION	1
Project Description	1
Scope of Work	2
Limitations.....	2
SITE EXPLORATION AND RECONNAISSANCE	3
Surface Conditions	3
Exploratory Borings	4
Fault Trench.....	4
Ground Water	6
VICINITY GEOLOGIC INVESTIGATIONS	6
GEOLOGIC SETTING	9
Regional Geology.....	9
Site Geology	10
Aerial Photographs and LIDAR	11
Ground Surface Fault Rupture Evaluation Discussion.....	11
Faulting and Seismicity	13
Table 1. Earthquake Magnitudes and Historical Earthquakes	13
Earthquake Design Parameters	14
Table 2. 2019 CBC Seismic Design Criteria	14
Other Geologic Hazards	14
CONCLUSIONS.....	16
FOUNDATIONS	17
Pier and Grade Beam Foundation.....	17
Lateral Loads for Drilled Piers	18
Combined Pier and Mat Foundation.....	18
Settlement	19
Basement Water Proofing.....	19
RETAINING WALLS	19
SLABS-ON-GRADE	21
General Slab Considerations	21
Exterior Flatwork.....	21
Interior Slabs	22
Structural Slabs.....	23
Subsurface Drainage.....	23
DRIVEWAY PAVEMENT.....	24
CONCRETE PAVERS	24
EARTHWORK.....	25
Clearing and Subgrade Preparation	25
Temporary Slopes and Excavations	25

TABLE OF CONTENTS
(Continued)

Material For Fill	26
Compaction.....	26
Table 3. Compaction Recommendations	26
Finished Slopes.....	27
Surface Drainage	27
FUTURE SERVICES	27
Plan Review.....	27
Construction Observation and Testing	28

REFERENCES

FIGURE 1 - VICINITY MAP

FIGURE 2 - ENGINEERING GEOLOGIC SITE PLAN

FIGURE 3 - VICINITY GEOLOGIC MAP

FIGURE 4 - REGIONAL FAULT AND SEISMICITY MAP

FIGURE 5 - REGIONAL LANDSLIDE MAPPING

FIGURE 6 - MAP OF NEARBY INVESTIGATIONS AND FAULT SPLAYS

FIGURE 7 - GEOLOGIC CROSS SECTIONS A-A' and B-B'

FIGURE 8 - TRENCH T-1

FIGURE 9 - SUBSLAB DRAINAGE DETAIL

APPENDIX A - LOGS OF EXPLORATORY BORINGS

 Figure A-1 - Key to Exploratory Boring Logs

 Figure A-2 - Key to Bedrock Descriptions

 Exploratory Boring Logs EB-1 through EB-4

APPENDIX B - SUMMARY OF LABORATORY TESTS

 Figure B-1 - Plasticity Chart

**GEOLOGIC AND GEOTECHNICAL INVESTIGATION
FOR
AWBREY TWO-LOT DEVELOPMENT
1061 LOS TRANCOS ROAD
PORTOLA VALLEY, CALIFORNIA**

INTRODUCTION

This report presents the results of our geologic and geotechnical investigation for the proposed two-lot development at 1061 Los Trancos Road in Los Trancos Woods, an unincorporated area of San Mateo County near Portola Valley, California. The location of the property is shown on the Vicinity Map, Figure 1. Traces of the San Andreas Fault have been identified in the nearby site vicinity. The purpose of this investigation has been to evaluate the potential for geologic hazards including ground surface fault rupture to affect the proposed development, to evaluate the foundation materials at the site of the proposed residences, and to provide geologic and geotechnical recommendations for the project.

Project Description

The project consists of subdividing your existing lot in unincorporated Los Trancos Woods and developing a residence on each of the subdivided lots. Each two-story residence is expected to be about 5,000 square feet in total size, which will include a below grade basement and an attached garage. The existing structures will be demolished prior to construction.

Lot 45 is the northwest parcel which includes a steeply sloping area at the rear. The finished floor elevation of the basement is expected to be approximately 902 feet, will be supported by a full height basement retaining wall at the front/upslope side and will daylight at the rear. The first level will have a finished floor elevation of 914 feet and the second level will have a finished floor elevation of 925 feet. An excavation of approximately 10 feet will be required.

Lot 46 is the southeast parcel which is gently to moderately sloping throughout. Although the general layout and size have been selected, the exact details have not yet been determined. On a preliminary basis, we understand the basement will have a finished floor elevation of approximately 907 feet, and will be supported by a full height basement retaining wall at the front/upslope side and will daylight at the rear. The first level will have a finished floor elevation of 918 feet and a second level will be constructed above. An excavation of approximately 7 feet will be required.



Scope of Work

Our scope of work for this investigation was presented in detail in our agreement with Mr. Craig Awbrey, dated January 29, 2020. In order to accomplish this investigation, we performed the following work.

- Review of geologic and seismic conditions in the site vicinity, including published reports, maps, and other site investigations conducted by our firm and others in the near-vicinity.
- Geologic reconnaissance of the subject site and immediate vicinity by our certified engineering geologist and senior staff geologist.
- Interpretation of stereo-pair aerial photographs.
- Subsurface investigation which consisted of logging an exploratory trench approximately perpendicular to the general trend of the mapped San Andreas fault. The trench was excavated with a backhoe and shored by the owner, Craig Awbrey, and logged by our staff. The field logging was conducted by our senior staff geologist, Alexander Shmurakov, G.I.T, and consulting engineering geologist, David F. Hoexter, C.E.G., assisted by additional geotechnical engineering staff, Darren Donlon, Emma Hoffman-Davis, and Will Zolan.
- Subsurface exploration including advancing and logging four exploratory borings, two on each of the proposed lots.
- Laboratory testing of selected samples to aid in soil classification and to help evaluate the engineering properties of the soil and rock encountered at the site.
- Engineering analysis and evaluation of the subsurface data to develop geotechnical design criteria.
- Preparation of this report presenting our findings and geotechnical and geologic recommendations for the proposed construction.

Limitations

This report has been prepared for the exclusive use of Mr. Craig Awbrey for specific application to the currently proposed two-lot development at 1061 Los Trancos Road in Los Trancos Woods, an unincorporated area of San Mateo County near Portola Valley, California. We make no warranty, expressed or implied, for the services we performed for this project. Our services were performed in accordance with the geologic and geotechnical engineering principles generally accepted at this time and location. This

report was prepared to provide geologic and engineering opinions and recommendations only. In the event there are any changes in the nature, design or location of the project, or if any future improvements are planned, the conclusions and recommendations contained in this report should not be considered valid unless 1) the project changes are reviewed by us, and 2) the conclusions and recommendations presented in this report are modified or verified in writing.

The analysis, conclusions, and recommendations presented in this report are based on site conditions as they existed at the time of our investigation; the currently planned improvements; review of readily available reports relevant to the site conditions; and laboratory test results. In addition, it should be recognized that certain limitations are inherent in the evaluation of subsurface conditions, and that certain conditions may not be detected during an investigation of this type. Changes in the information or data gained from any of these sources could result in changes in our conclusions or recommendations. If such changes occur, we should be advised so that we can review our report in light of those changes.

SITE EXPLORATION AND RECONNAISSANCE

Subsurface exploration and site reconnaissance were performed on February 28, and March 10, 2020. Our subsurface exploration consisted of advancing four exploratory borings and excavating a fault trench. The exploratory borings were advanced to depths ranging from 9.75 to 18 feet using portable Minuteman drilling and sampling equipment. The fault trench was excavated to a maximum depth of 12 feet and logged from May 6 to May 8, 2020.

The approximate locations of the borings and fault trench are presented on the Engineering Geologic Site Plan, Figure 2. The logs of the exploratory borings, the results of our laboratory tests, and the logs of the fault trench are attached in Appendices A and B, respectively.

Surface Conditions

The site is located in a residential area along the northeast side of a winding segment of Los Trancos Road. At the time of our investigation, the northwest portion of the site was occupied by a single-story, wood-frame residence which had a wood siding exterior. A detached garage was located in the southeast portion of the property where an asphalt concrete driveway provided access to Los Trancos Road. An asphalt walkway was located between the two structures in the central portion of the site. A raised wood deck was located at the front of the residence. The site was landscaped with native grasses, small to large shrubs and small to large trees.

The site generally sloped gently to moderately down to the northeast at a declination of about 5:1 (horizontal:vertical); however, the north corner of the property sloped down steeply at a declination of about 2:1 (horizontal:vertical) which leveled out at the base of the approximately 10- to 15-foot high slope. We suspect that some fill may have been placed along the downslope portion of the residence. A drainage swale was observed along the northwestern portion of the property from Los Trancos Road down to the lower north corner.

According to the owner, the northern structure was a house that was reportedly constructed in 1930. The house was originally built without a foundation, and a foundation was later added to the northeastern portion in 1984. The southern structure was a garage that was reportedly built in 1932. Based on our observation of the perimeter stem walls and the accessible crawl space areas, the exposed shallow-type foundations for both of these structures generally appeared to be in relatively good condition with a few hairline cracks and no obvious lateral or vertical offsets. The asphalt concrete driveway and walkway appeared to be in fair condition with many cracks up to about ½-inch observed throughout. Roof downspouts appeared to discharge into a closed pipe system.

Exploratory Borings

At the locations of our exploratory borings, we generally encountered about 3 to 4 feet of firm to very stiff sandy lean clay of low plasticity. Below the sandy lean clay, we encountered 1 to 4 feet of residual soil comprised of stiff to very stiff sandy lean clay of low to moderate plasticity. The residual soil appeared to have a bedrock fabric and was in the process of weathering to clay. Below the residual soil, we encountered very severely weathered Santa Clara Formation bedrock to the maximum depths explored of 18, 9.75, 18, and 10.5 feet in Borings EB-1, EB-2, EB-3, and EB-4, respectively. Borings EB-2 and EB-4 were terminated due to sampler refusal conditions.

A Liquid Limit of 32 and a Plasticity Index of 14 were measured on a sample of near-surface soil obtained from Boring EB-1. A Liquid Limit of 24 and a Plasticity Index of 9 were measured on a sample of near-surface soil obtained from Boring EB-4. These test results indicate the surface and near-surface soil at the site have low plasticity and a low potential for expansion.

Fault Trench

An exploratory trench (T-1) approximately 90 feet in length was excavated and logged May 6 to 8, 2020; the location is shown on Figure 2.

The trench was excavated with a track-mounted excavator. The excavation was about 36 inches wide and extended to a maximum depth of about 12 feet below grade. The trench sidewalls were shored for entry by the client and cleaned and logged by our staff. Upon completion of logging, the trench sections were backfilled using the materials from the excavation. We were not present during the backfill of the trench.

The trench location as shown on Figure 2 was approximately determined by measuring from existing topographic and site features (walls, buildings, etc.) shown on the site plan. The locations should be considered accurate only to the degree implied by the method used.

The excavator encountered a concrete septic tank in the path of the trench excavation. The septic tank remained in place and the trench was terminated on either side of the tank. It was not possible to excavate an offset trench to cover the interval blocked from view by the septic tank. The trench exposure was viewed by Craig Stewart, PG, and John Wallace, CEG, of Cotton, Shires and Associates, San Mateo County Geotechnical Consultants and anticipated peer reviewers for this project.

The trench was excavated at an orientation approximately perpendicular to the trend of the San Andreas fault, and provided the maximum feasible site coverage given the physical constraints of the property. It was not feasible to excavate additional trenches on the property due to access and space constraints. In our opinion the trench (in conjunction with a trench previously excavated on the adjacent property to the south) provides reasonable lateral coverage of the currently proposed residence footprints.

Our interpretation of the soil and formational materials encountered in the exploratory trench is shown on Figure 8, Fault Trench T-1. The observed materials are identified by lithology and origin, which are described on the log of Trench T-1. The following discussion describes the four units, Units A through D. For a more detailed description of the fill and earth materials encountered please refer to Figure 8.

Unit A consisted of utility/pipeline backfill and of surficial disturbed soils. The disturbed surficial soils consist primarily of sandy lean clay and are approximately 2 feet thick.

Unit B consisted of sandy lean clay which we interpreted as residual soil (severely weathered bedrock). Unit B was definitively identified along only a 20 foot segment of the trench (Stations 40 to 60), although sub-units C1 and C2A are laterally present at the same stratigraphic position and likely also represent residual soil.

Unit C was identified as Santa Clara Formation, comprising four sub-units differentiated primarily by presence or absence of gravel and larger cobbles and by the percentage and color of the clay matrix. Sub-units C2A and C3 are likely equivalent to Unit B, severely weathered bedrock and/or residual soil. This unit is essentially massive, with little indication of bedding. Based on our overall understanding of the vicinity geology, the Santa Clara Formation sediments have been translocated downslope by large-scale and currently dormant landsliding.

Unit D consists of disturbed soil underlying the apparent original septic tank. Unit D is derived from Unit C3, which was present in Trench T-1 on both sides of the former tank location, see Figure 8.

Ground Water

Free ground water was not encountered in our borings during drilling or during our fault trench investigation. The borings were backfilled immediately following drilling and sampling; therefore, a stabilized ground water level measurement was not obtained. The fault trench was left open for two days before being backfilled. During this time, we only observed a minor amount of water pooled in one portion of the fault trench, likely a leak from the septic tank. Please be cautioned that fluctuations in the level of ground water can occur due to variations in rainfall, landscaping, underground drainage patterns, and other factors. It is also possible, and perhaps even likely that perched ground water conditions could develop in the soils and near the surface of the bedrock during and after significant rainfall or due to landscape watering at the upslope areas.

VICINITY GEOLOGIC INVESTIGATIONS

The California Division of Mines and Geology (1974) identifies three traces of the San Andreas fault in the near site vicinity. One trace is located approximately 200 feet downslope to the northwest. Two traces are respectively approximately 100 feet and 300 feet upslope to the southwest. Various publications (Brabb and Olson, 1986; Brabb and Pampeyan, 1972; Brabb and others, 1998 and 2000) identify one San Andreas fault trace within Los Trancos Woods, located immediately west of the subject property. These publications variably indicate that Santa Clara Formation materials are faulted against each other or against Franciscan Assemblage rocks.

Regional mapping by Brabb and others (2000) indicate that Franciscan Complex greenstone generally underlies areas northeast of the main trace of the San Andreas fault and bedrock of the Santa Clara Formation generally underlies areas southwest of the main fault trace. Previous mapping by Brabb and others (1998) indicates the presence of Santa Clara Formation on both sides of the fault in the immediate site vicinity.

Regional landslide mapping by Brabb and Pampeyan (1972) indicates that most of the Los Trancos Woods area is underlain by a large deep-seated probable landslide deposit, see Figure 5. The Geologic Map of the Town of Portola Valley also shows large landslides toeing-out downslope of the properties to the north. Thus, it is likely that upslope Santa Clara Formation has been translocated by landsliding downslope and overlies Franciscan Complex materials which likely occur at greater depth.

In summary, published geologic maps identify the site and vicinity as underlain by Santa Clara Formation, and depict up to three fault traces of the San Andreas fault zone, some of which are located east of the site, and some of which are located west of the site. None of the traces are identified closer than approximately 100 feet from the site.

A limited number of fault rupture hazard studies have been conducted of properties in the near site vicinity. We reviewed reports provided by San Mateo County and additional sources. The various relevant investigations are discussed, below. Active faulting was identified at one site only, Location 10.

Location 1 – Murray Engineers Inc. (11/20/2014)

Murray Engineers (11/20/2014) (Site 1, Figure 6) investigated the fault rupture hazard of lot 080-082-040 on Los Trancos Road, approximately 100 feet west of the subject property. Three trench segments were excavated in a perpendicular orientation to the San Andreas Fault. The fault was not encountered.

Location 2 – Romig Engineers Inc. (2/6/2008)

Romig Engineers (2/6/2008) (Site 2, Figure 6) investigated the fault rupture hazard of 124 Foxwood Road (Weiss), approximately 500 feet south of the subject property. Two trenches were excavated to maximum depths of 16.5 feet approximately perpendicular to the San Andreas Fault trend. The fault was not observed.

Location 3 – Hoexter Consulting (2003)

Hoexter Consulting (2003) (Site 3, Figure 6), in association with Craig Harwood, CEG, investigated the fault rupture hazard of a portion of 1065 Los Trancos Road, immediately adjacent on the south to the subject site (trench location shown of Figure 2 of this report). One trench, 11 to 13 feet deep, was located perpendicular to the San Andreas fault trend. The fault was not observed.

Location 4 – Steven F. Connelly, C.E.G (2002)

Steven F. Connelly, CEG, Consulting Geologist (2002) conducted an engineering geologic study of 1036 Los Trancos Road, located approximately 150 feet northwest of the subject site (Site 4, Figure 6). A continuous trench was excavated across the property. The investigation concluded that although traces of the San Andreas system were present both west and east of the site, an active fault did not underlie the investigated property (within the 185-foot long exploratory trench) and that there was a low potential for fault rupture at the site.

Location 5 – Steven F. Connelly, C.E.G (2000)

Connelly (2000) performed an Engineering Geologic Investigation for a proposed residence addition at 445 Ramona Road about 1000 feet southeast of the subject site (Site 5, Figure 6). Connelly did not identify evidence of faulting or landsliding at the home site.

Location 6 – Louis A. Richardson, C.E.G. (1990)

Louis A. Richardson, C.E.G. (1990) performed an investigation at 1144 Los Trancos Road, approximately 400 feet west of the subject property (Site 6, Figure 6). Richardson extended a trench across a postulated trace of the San Andreas fault. Richardson did not observe indications of faulting, although he did observe indications of past landsliding.

Location 7 – Baldwin Consultants (1985)

Baldwin Consultants (1985) completed a Geotechnical Investigation for a large landslide complex referred to as the Vista Verde Landslide Area approximately 1,000 feet to the southeast of the subject site (Site 7, Figure 6). A fault and landslide map was produced by Baldwin based upon review of air photos as part of that investigation. Several traces of the San Andreas fault zone were mapped based upon a series of northwest trending lineations observed on the air photos. A large old landslide complex located near Old Spanish Trail and toeing out into Los Trancos Creek was mapped underlying the Los Trancos Woods area. Several smaller dormant and active landslides were mapped within the landslide complex. The Baldwin Consultants' map; however, did not extend north to include the area of the subject property.

Location 8 – Harlan Tait and Associates (HTA, 1993, 1997)

Harlan Tait and Associates (HTA, 1993, 1997) conducted extensive fault investigation of the Blue Oaks Subdivision, situated to the northwest (Site 8, Figure 6). Their work extended to within approximately 300 feet northwest of the subject property. HTA identified two prominent traces of the San Andreas fault, which project towards Los Trancos Woods. The two traces approximately correspond to identified traces located up- and down-slope of the site.

Location 9 – Upp Geotechnology Inc. (1996)

Upp Geotechnology Inc. (1996) performed an investigation at 1227 Los Trancos Road, approximately 800 feet south of the subject site (Site 9, Figure 6). The investigation identified an active trace of the San Andreas fault as a 3 to 8 foot wide sheared zone in each of two trenches, and 10-foot setbacks were recommended from both sides of the fault. The Upp investigation identified older landslide debris ranging from 10 to 20 feet thick within the trenches and one caisson excavation.

Location 10 – JCP (1981) and Upp Geotechnology (1997)

JCP (1981) and Upp Geotechnology (1997, unpublished) investigated 130 Foxwood Road (Site 10, Figure 6). The investigations included advancing two soil borings, two test pits and three trenches, and were located in the central part of the property approximately 650 feet southeast of the subject site. The Upp trenches were approximately 14 feet deep and identified younger colluvium deposited over older colluvium and “Bedrock/Old Landslide Debris”, with no indications of faulting. The JCP trench, 8 to 13 feet deep, also interpreted colluvium overlying Santa Clara Formation sediments, which were inclined into the slope at an average of 30 degrees to the south along a strike of north 50 degrees west. There were no indications of faulting. Each investigation identified dormant and recent landsliding at the south end of the site.

Location 11 - Upp Geotechnology Inc. (2000)

Upp Geotechnology (2000) conducted a limited geotechnical investigation of 124 Foxwood Road (Weiss) (Site 11, Figure 6), approximately 500 feet south of the subject site. The purpose of the investigation was to assess a proposed septic system expansion and to evaluate the front foundation of the residence, where settlement had occurred. A hand-excavated pit and three borings which extended to a maximum depth of 49 feet were located downslope of the residence. Upp identified approximately 19 feet of colluvium, underlain by “ancient” landslide debris. There were no indications of faulting, although the investigation was not directed towards fault rupture hazard.

GEOLOGIC SETTING**Regional Geology**

The site is located within the central region of the Coast Ranges Geomorphic Province, which extends from the Oregon border south to the Transverse Ranges. The general topography in this province is characterized by subparallel, northwest trending mountain ranges and intervening valleys. The region has undergone a complex geologic history of sedimentation, volcanic activity, folding, faulting, uplift and erosion. The relatively flat-lying, alluviated San Francisco Bay Plain is situated to the northeast of the site.

The immediate site vicinity (Figure 3) is generally underlain at depth by deposits of the Upper Pliocene and Lower Pleistocene Santa Clara Formation, consisting of irregularly bedded mudstone, sandstone and conglomerate. The Santa Clara Formation is characterized by moderately consolidated clay, silt, sand and gravel. In addition, various rock types of the Cretaceous Franciscan Assemblage are mapped northeast of the site.

The slopes are commonly (although not at the subject site) mantled with deposits of colluvium. Active landslides which are relatively limited in extent underlie parts of Los Trancos Woods. Regional landslide mapping by Brabb and Pampeyan (1972) and Leighton and Associates (1976) indicate that most of the Los Trancos Woods area is further underlain by large deep-seated probable landslide deposits, see Figure 5. Very large deep-seated bedrock landslides such as this are commonly thought to have initiated during the Pleistocene era when the climate in northern California was significantly wetter than present day. These large landslide masses often incorporate bodies of intact rock that may be stabilized under present climatic conditions. There are indications that these widespread landslides can be reactivated in response to periods of extended rainfall, particularly in conjunction with strong seismic shaking. Several of these similar landslides in the Santa Cruz Mountains were reactivated in response to shaking during the 1989 Loma Prieta Earthquake (Spittler, 1990). There is no economically feasible method of mitigating the movement of such a large-scale landslides which underlies the larger Los Trancos area.

Site Geology

A site plan with observed geologic features is presented on Figure 2. We did not observe bedrock outcrops in the immediate site vicinity, only within the excavated trench at the site. The ground surface was entirely covered by disturbed residual soil. Colluvium was not observed.

Younger surficial materials existing at and near the site included residual soil derived from the Santa Clara Formation. These materials are described in greater detail in the trench log presented in Figure 8 and in the section titled, "Subsurface Exploration and Reconnaissance." We did not observe identifiable fill on site, except in areas that have been backfilled around and over utility pipes. Fill was initially suspected to occur under the northeast corner of the existing residence near the crest of the adjacent slope. Our Boring EB-3 did not indicate that this material was fill, and it is likely that the foundation of the residence in this area was embedded into the residual soil and/or underlying Santa Clara Formation, which were encountered 3 and 8 feet respectively below the ground surface. The foundations for the adjacent garage structure were observed to be quite tall, extending 4 feet above the ground surface, implying that the structure was constructed at/near existing grades and that fill was not placed underneath the garage slab.

There were no indications of soil creep or of deep-seated landsliding in the immediate vicinity of or within the site. We specifically observed the approximately 90 year old residence and 88 year old concrete slab-floored garage for indications of settlement or of lateral movement. Each of the two structures appeared to be performing relatively well from a geologic and geotechnical perspective. We did not observe springs or indications of a high water table.

Aerial Photographs and LIDAR

Eight sets of aerial photographic stereo pairs were reviewed for this reconnaissance. The photos were flown from 1955 through 2005. Scales ranged from 1:7,200 to 1:33,500. The photos are referenced at the conclusion of this report. We also interpreted LIDAR imagery available on Google Earth by download from a USGS website.

The site vicinity was well developed at the time of the earliest imagery (1955). The road network was constructed, and there were numerous structures, primarily single-family residences, garages, sheds, and other small structures. Subsequent imagery appeared essentially unchanged. Viewing of the site and vicinity was obscured by a prominent tree canopy. Connelly (2002) viewed air photos which included earlier sets flown in 1939 and 1943. His observations and conclusions related to the nearby site were similar to ours.

Although air photo imagery is of marginal utility in identifying fault-related features at the subject site, there were no indications of lineations, springs, tonal changes or other common fault-related features within or projecting to the site.

There were no lineations or other features suggestive of faulting within or projecting towards the site on the LIDAR imagery. The imagery indicates an arcuate feature suggestive of a landslide head scarp on the immediate downslope properties. This feature does not coincide with the possible small landslide bowl located immediately northeast of the existing residence. This bowl is also not apparent on the Google imagery despite the obvious increase in slope inclination at this location, see Figure 2.

Ground Surface Fault Rupture Evaluation Discussion

Our fault investigation was intended to evaluate the ground surface rupture potential of the San Andreas fault at the location of the subject site, and to establish the fault's distance to proposed residences and the inclination of the fault, if present. In addition, we observed the soils for indications of landsliding or other geologic hazards. Our subsurface observations are shown on the trench log (Figure 8) and are summarized on Cross Sections A-A' and B-B' (Figure 7).

The shallow-most identified soil (Unit A) consists of local fill placement and surficial disturbed soil. This unit was essentially continuous along the entire trench. Discontinuous sandy lean clay (Unit B) interpreted as residual soil (intensely in-situ weathered rock) was identified from Station 40 to 62. There were no indications of faulting at the locations where Unit B was not present, and its absence elsewhere along the trench is likely due to ground surface disturbance during and subsequent to site development. We did not observe definitive colluvium. We observed Santa Clara Formation sediments (Unit C) underlying the surface soil along the entire length of the trench. The rock unit observed was generally massive in nature and did not display any evidence of bedding or measurable planar features. We identified subtle variations in lithology (sub-units C1, C2, C2a, and C3. Sub-units C1 and C2A are also likely residual soil. Sub-unit C3 was observed at the base of the trench as a discontinuous stratum along the base of the trench with increased clay content and decreased gravels in comparison with the overlying deposits. We infer this subunit to be continuous at greater depth along the entire trench, and in particular we infer it to have been present at the location of the septic tank, where we have identified disturbed soil related to a former redwood tank, which appeared to be derived from the Sub-unit C3 present at both sides of the tank. Unit C consisted of weathered sandstone, claystone, and conglomerate. The Santa Clara Formation bedrock in this area appeared to have been mobilized in a landslide in the ancient past, likely explaining the lack of visible depositional features of the original formation. There were no indications of faulting, including observable folds, shears, or offset beds.

A trench was excavated by Hoexter Consulting (2003) on the property immediately to the southeast. This trench provides partial “shadowing” of a portion of the subject site. The Hoexter trench provides substantial “shadowing” of the trench gap resulting from the presence of the septic tank. Conditions at the adjacent property appear to be very similar to the subject site, with Santa Clara Formation sediments, possibly slide debris, inclined into the slope and no indications of faulting.

In conclusion, we observed no indications of surface fault traces or of secondary shears or faults which would rupture the ground surface within the footprint of the proposed residences. An active trace of the San Andreas Fault, as identified in trenches excavated and logged by Upp Geotechnology (1996), is approximately 400 feet distant from the southern corner of the property. This fault trace is shown on Figure 6. In our opinion, the risk of fault ground surface rupture impacting the proposed two structures is low.

Faulting and Seismicity

The San Francisco Bay Area is located in an active seismic region. Earthquakes in the region result from strain energy constantly accumulating because of the northwestward movement of the Pacific Plate relative to the North American Plate. On average about 1.6-inches of movement occurs per year. Historically, the Bay Area has experienced large, destructive earthquakes in 1838, 1868, 1906 and 1989. The faults considered most likely to produce large earthquakes in the area include the San Andreas, San Gregorio, Hayward, and Calaveras Faults. The San Andreas fault is located in the immediate site vicinity, with the likely 1906 San Francisco Earthquake ground rupture trace approximately 400 feet southwest of the site. The San Gregorio fault is located approximately 11 miles southwest of the site. The Hayward and Calaveras faults are located approximately 19 and 23 miles northeast of the site, respectively. These faults and significant earthquakes that have been documented in the Bay Area are listed in Table 1 below and are shown on the Regional Fault and Seismicity Map, Figure 4.

**Table 1. Earthquake Magnitudes and Historical Earthquakes
Awbrey 2-Lot Development
Los Trancos Woods, California**

<u>Fault</u>	<u>Maximum Magnitude</u>	<u>Historical Earthquakes</u>	<u>Estimated Magnitude</u>
San Andreas	8.3	1989 Loma Prieta	6.9
		1906 San Francisco	8.3
		1865 N. of 1989 Loma Prieta Earthquake	6.5
		1838 San Francisco-Peninsula Segment	6.8
		1836 East of Monterey	6.5
Hayward	7.3	1868 Hayward	6.8
		1858 Hayward	6.8
Calaveras	7.3	1984 Morgan Hill	6.2
		1911 Morgan Hill	6.2
		1897 Gilroy	6.3
San Gregorio	7.3	1926 Monterey Bay	6.1

In the future, the subject property will undoubtedly experience severe ground shaking during moderate and large magnitude earthquakes produced along the San Andreas fault or other active Bay Area fault zones. Using information from recent earthquakes, improved mapping of active faults, ground motion prediction modeling, and a new model for estimating earthquake probabilities, a panel of experts convened by the U.S.G.S. have concluded there is a 72 percent chance for at least one earthquake of Magnitude 6.7 or larger in the Bay Area before 2043. The Hayward fault has the highest likelihood of an earthquake greater than or equal to magnitude 6.7 in the Bay Area, estimated at 33 percent, while the likelihood on the San Andreas and Calaveras faults is estimated at approximately 22 and 26 percent, respectively (Aagaard et al., 2016).

Earthquake Design Parameters

The State of California currently requires that buildings and structures be designed in accordance with the seismic design provisions presented in the 2019 California Building Code and in ASCE 7-16, “Minimum Design Loads for Buildings and Other Structures.” Based on site geologic conditions and on information from our subsurface exploration at the site, the site may be classified as Site Class C, very dense soil and soft rock, in accordance with Chapter 20 of ASCE 7-16. Spectral Response Acceleration parameters and site coefficients may be taken directly from the U.S.G.S. website based on the longitude and latitude of the site. For site latitude (37.3498), longitude (-122.1986) and Site Class D, design parameters are presented on Table 2 below.

**Table 2. 2019 CBC Seismic Design Criteria
Awbrey 2-Lot Development
Portola Valley, California**

<u>Spectral Response Acceleration Parameters</u>	<u>Design Value</u>
Mapped Value for Short Period - S_S	2.479
Mapped Value for 1-sec Period - S_1	1.036
Site Coefficient - F_a	1.2
Site Coefficient - F_v	1.4
Adjusted for Site Class - S_{MS}	2.975
Adjusted for Site Class - S_{M1}	1.451
Value for Design Earthquake - S_{DS}	1.983
Value for Design Earthquake - S_{D1}	0.967

Other Geologic Hazards

We briefly reviewed the potential for geologic hazards other than fault rupture to impact the site, considering the geologic setting, and the soil and rock encountered during our investigation. The results of our review are presented below:

- **Ground Shaking** - The site is located in an active seismic area. Moderate to large earthquakes are probable along several active faults in the greater Bay Area over a 30 to 50 year design life. Strong ground shaking should therefore be expected several times during the design life of the development, as is typical for sites throughout the Bay Area. The improvements should be designed in accordance with current earthquake resistance standards.

- Liquefaction - Liquefaction occurs when saturated sandy soils lose strength and flow like a liquid during earthquake shaking. Ground settlement often accompanies liquefaction. Soils most susceptible to liquefaction are saturated, loose, silty sands, and uniformly graded sands. Since saturated sands and other soils prone to liquefaction were not encountered in our borings, and since bedrock was encountered at relatively shallow depths across the site, in our opinion, the likelihood of liquefaction occurring at the site is low. In addition, published maps indicate that the site is not within a zone of potential liquefaction (State of California Mindego Hill Quadrangle Seismic Hazard Zone Map, 2005).
- Differential Compaction - Differential compaction occurs during moderate and large earthquakes when soft or loose, natural or fill soils are densified and settle, often unevenly across a site. Since the soils encountered in our trench and our borings were generally stiff to hard clays and weathered bedrock, in our opinion, the likelihood of significant differential compaction of the native soils and rock encountered is low. However, since we did not observe backfill of the trench, in the event that the backfill was not properly compacted, there may be a potential for settlement of the trench backfill in the event of a moderate to large earthquake. In our opinion, the likelihood of significant differential compaction affecting the proposed structures is low provided the foundations for the improvements will extend into weathered bedrock.
- Tsunamis, Seiches and Flooding - The site is located inland from low-lying areas subject to inundation by tsunami. There are no upstream dams, reservoirs or lakes with the potential for catastrophic failure due to seismic shaking. Two small shallow impoundments are located upslope at and close to the intersection of Lake Road and Old Spanish Trail. Were they to fail, the easternmost of these two impoundments would discharge in the general direction of the subject site, but the volume of potential flow is small and the subject site is not directly within the potential flow channel of released water.
- Slope Stability (Regional) - The site is mapped within a zone of potential earthquake induced landslides on the State of California Mindego Hill Quadrangle Seismic Hazard Zone Map (2005). Various investigators and publications have proposed that much of Los Trancos Woods is underlain by deep landsliding, and there is general concurrence with this concept. These landslides are generally considered to have occurred during periods of significantly greater rainfall than the present, and not to be currently active. A small potential exists for reactivation of the deep seated slide underlying the site and vicinity. The site bears this risk along with all other properties in the vicinity much of Los Trancos Woods. During our surface site reconnaissance and review of aerial photographs we did not directly identify any landslides with ground surface expression. At this time there are no indications of active landsliding at the site.

- Slope Stability (Local) - The ground surface downslope northeast of and immediately adjacent to the existing residence within the north corner of the site is steeper than nearby slopes and is roughly concave in plan view. This localized occurrence is not apparent on LIDAR imagery (see previous aerial photo interpretation discussion). This occurrence may have resulted from past shallow landsliding, with the landslide toe located offsite on the adjacent downslope properties (although apparently removed by site development). There are no indications of lateral movement within the existing adjacent approximately 90 year old structure. Reactivation of movement on this slope, or upslope migration of the apparent head scarp, is in our opinion unlikely. In addition, we have recommended structures be supported primarily with pier foundations embedded well into competent bedrock, below a depth of possible future shallow slope movement.

CONCLUSIONS

Our geologic evaluation concluded that the potential for ground surface fault rupture in the areas of our trench and shadowed by the trench is low. Therefore, from a geologic and geotechnical viewpoint, the site is suitable for the proposed two-lot residential development provided the recommendations presented in our report are followed during design and construction. Specific geotechnical recommendations are presented in the following sections of this report.

The primary geotechnical concerns for the proposed project are the moderately to steeply sloping nature of the site, the presence of surface and residual soil, particularly on the downslope side of the northwest proposed residence, which may be prone to downslope soil creep on the moderate to steep slopes, the variable support conditions across the lower level (i.e., the basement level will be partially situated in a cut exposing bedrock and partially situated on upper colluvial soils), and the potential for severe ground shaking at the site due to moderate to large earthquakes in the area.

Based on our borings and fault trench, the site was blanketed with about 3 to 5 feet of residual soils. In addition, we note that backfilling of the excavated fault trench was not completed under our observation. Based on the finished floor elevations of the basement levels of the proposed residence on Lots 45 and 46, we expect that the front/upslope portions of the basement levels will expose bedrock which then transitions to residual soil in the central portion and surface or colluvial soils along the rear portions where the basements are expected to daylight at or near existing site grades.

In our opinion, in order to reduce the potential for differential movement across the residences and to provide sufficient lateral support, the proposed residences should be supported on drilled piers that are embedded well into weathered bedrock below the upper surface and colluvial soils. As an alternative to drilled piers, the basement retaining walls associated with the lower level areas expected to be constructed in a cut may be supported on a combined mat slab and pier foundation bearing in bedrock. On a preliminary basis this will be approximately within the front/upslope one-third of the basement footprints on lots 45 and 46 based on the preliminary finished floor elevations of 902 feet and 907 feet, respectively.

Providing adequate waterproofing of the basement mat/slab and walls is essential for the success of the basement. Please note however, providing water-proofing recommendations is outside of our scope of services and expertise. In addition, to reduce the possibility of water pressure developing below the basement floor damp-proofing system, the bottom of the drainage system behind the basement retaining walls preferably should extend below the bottom of the basement slab elevation.

Because subsurface conditions may vary from those encountered at the locations of our exploratory borings and trench, and to observe that our recommendations are properly implemented, we recommend that we be retained to 1) review the project plans for conformance with our report recommendations; and 2) observe and test during earthwork and foundation construction.

FOUNDATIONS

Pier and Grade Beam Foundation

In our opinion, the residences may be supported on a drilled pier and grade beam foundation bearing in weathered bedrock. Piers should be at least 16 inches in diameter and extend at least 14 feet below the bottom of the grade beam, and at least 6 feet into weathered bedrock, whichever is deeper.

Piers may be designed for an allowable skin friction of 550 pounds per square foot for dead plus live loads, with a one-third increase allowed for total loads including wind or seismic forces. The uplift capacity of the piers may be based on a skin friction value of 440 pounds per square foot. The vertical resistance of the upper 4 feet should be neglected in design. Piers should have a center-to-center spacing of at least three pier diameters.

In order to improve long term performance of the pier foundations, we recommend that a series of relatively rigid grade beams be provided between piers supporting the proposed structures. The grade beam below the structures should extend at least 8 inches below the slab subgrade elevation and at least 24 inches below exterior grade along the perimeter of the structures within 15 feet of sloping ground.

Pier drilling should be observed by our representative, to establish that piers are bearing in competent materials, extend the required depth into competent bedrock, and that the pier excavations are properly cleaned. The pier depths recommended above may require adjustment if differing conditions are encountered during drilling. While we expect that moderate sized drilling equipment can obtain the required depths, due to the hardness of the bedrock present at the site, a drill bit equipped with carbide or other teeth, or a rock core barrel may be required.

Concrete should be placed in the pier excavations as soon as practical after drilling, preferably the day of drilling. Ground water seepage may be encountered during pier drilling and it is possible that ground water seepage could cause some sloughing or caving of the pier holes. This can be further evaluated during drilling of the initial piers. If ground water cannot be effectively pumped from the pier holes, concrete will need to be placed in the pier holes by the tremie method.

Lateral Loads for Drilled Piers

Due to the potential for lateral creep of the near-surface soils, we recommend that the upper 4 feet of the piers be designed to resist an active soil pressure equal to 65 pounds per cubic foot, acting against 2 times the projected area of the piers in the downhill direction. The active load and other lateral loads may be resisted by passive earth pressure based upon an equivalent fluid pressure of 350 pounds per cubic foot, acting on 2 times the projected area of the pier in native soil and bedrock below a depth of 4 feet. The passive resistance of the upper 4 feet of the surface should be neglected.

Combined Pier and Mat Foundation

In our opinion, a combined mat and drilled pier foundation may be used for the basement retaining walls where the mat foundation will be bearing on weathered bedrock (the front (upslope one-third of the basement)). An allowable bearing pressure of 2,500 pounds per square foot for dead plus live loads, with a one-third increase allowed for total loads including wind or seismic forces, may be used in its design. A frictional resistance of 0.3 and an equivalent fluid pressure of 300 pounds per cubic foot may be used in design to resist lateral loading.

However, since a water-proofing membrane is expected to be installed between the bottom of the mat and subgrade soil, the structural engineer should consult with the water-proofing consultant for the coefficient of friction between the membrane and subgrade soil. We also recommend that a similar pier spacing and depth be used for the basement retaining walls as is being used for the remaining portions of the structure.

The mat should be reinforced to provide structural continuity and to permit spanning of local irregularities. A water-proofing system designed by others should be installed below and around the edges of the mat foundation (and behind the basement walls).

The bottom of the excavation for the basement should be cleaned of disturbed bedrock and/or soil debris. Our representative should observe the excavation to confirm that it exposes competent suitable bedrock and to evaluate whether proof rolling or scarification and compaction of the subgrade is needed. If competent bedrock is not encountered across the basement excavation, some further excavation and supplemental recommendations likely will be required.

Settlement

Thirty-year post-construction differential settlement due to static loads is not expected to exceed $\frac{3}{4}$ -inch across the proposed residence(s), provided the foundations are designed and constructed as recommended.

Basement Water Proofing

We have not provided recommendations regarding the method or details for basement damp-proofing since design of damp-proofing systems is outside of our scope of services and expertise. Installing adequate damp-proofing below and behind the edges of the basement floor and behind the basement walls is essential for the success of the basement structure. Placing concrete with a low water cement ratio should be considered as one step of good damp-proofing as discussed in the Slab-On-Grade section below. The damp-proofing system below the basement floor slab may be placed directly on a subslab drainage system, 4 to 8 inches of $\frac{1}{2}$ - to $\frac{3}{4}$ -inch crushed rock, or on a thin working slab, as determined by the water-proofing consultant.

RETAINING WALLS

Retaining walls should be designed to support adjacent native material, fill, and backfill. Retaining walls with level backfill that are not free to deflect or rotate, such as the basement retaining walls, should be designed to resist an equivalent fluid pressure of 45

pounds per cubic foot plus an additional uniform lateral pressure of $8H$ in pounds per square foot, where H is the height of the wall in feet. Retaining walls with level backfill that are free to rotate, such as site retaining walls, may be designed to resist an equivalent fluid pressure of 45 pounds per cubic foot.

Walls with sloping backfill should be designed for an additional equivalent fluid pressure of 1 pound per cubic foot for every 1.5 degree of slope inclination. In addition, where retaining walls will be subjected to surcharge loads, such as from adjacent foundations, vehicle loads, or construction loading, the walls should be designed for an additional uniform lateral pressure equal to one-third of the surcharge pressure for walls able to yield and one-half of the surcharge pressure for the restrained condition.

Based on the site peak ground acceleration (PGA), on Seed and Whitman (1970); Al Atik and Sitar (2010); and Lew et al. (2010); seismic loads on retaining walls that can yield may be simulated by a line load of $14H^2$ (in pounds per foot, where H is the wall height in feet). Seismic loads on walls that cannot yield, such as the basement walls, may be subjected to a seismic load as high as about $20H^2$. This seismic surcharge line load should be assumed to act at $1/3H$ above the base of the wall (in addition to the active wall design pressure of 45 pounds per cubic foot for level wall backfill, with additional 1 pound per cubic foot for every 1.5 degree of slope inclination for sloping backfill).

To prevent buildup of water pressure from surface water infiltration, a subsurface drainage system should be installed behind the walls. The drainage system should consist of a 4-inch diameter perforated pipe (perforations placed down) embedded in a section of 1/2- to 3/4-inch, clean, crushed rock at least 12 inches wide. Backfill above the perforated drain line should also consist of 1/2- to 3/4-inch, clean, crushed rock to within about 1½ to 2 feet below exterior finished grade. A filter fabric should be wrapped around the crushed rock to protect it from infiltration of native soil. The upper 1.5 to 2 feet of backfill should consist of compacted native soil. The perforated pipes should discharge to a suitable location and daylight to a low point on the site. Damp-proofing of the walls should be included in areas where wall dampness and efflorescence would be undesirable.

Miradrain, Enkadrain or other drainage fabrics approved by our office may be used for wall drainage as an alternative to the gravel drainage system described above. If used, the drainage fabric should extend from a depth of about 1 foot below the top of the wall backfill down to the drain pipe at the base of the wall. A minimum 12-inch wide section of ½-inch to ¾-inch clean crushed rock and filter fabric should be placed around the drainpipe, as recommended previously.

Backfill placed behind the walls should be compacted to at least 90 percent relative compaction using light compaction equipment. If heavy equipment is used for compaction of wall backfill, the walls should be temporarily braced. The backfill behind the walls should be placed on level benches, rather than directly on the sloping grade.

Basement retaining walls should be supported on a pier or combined pier and mat foundation designed in accordance with the recommendations presented previously. Site retaining walls to be built on or near sloping ground generally should be supported on drilled piers designed in accordance with the above recommendations. During design, we can provide additional guidelines regarding foundation support for site retaining walls.

SLABS-ON-GRADE

General Slab Considerations

To reduce the potential for movement of slab subgrades, at least the upper 6 inches of surface soil should be scarified and compacted at a moisture content above the laboratory optimum. The native soil subgrade should be kept moist up until the time the non-expansive fill, crushed rock and vapor barrier, and/or aggregate base is placed.

Slab subgrades and non-expansive fill should be prepared and compacted as recommended in the section of this report titled "Earthwork." Exterior flatwork and interior slabs-on-grade should be underlain by a layer of non-expansive fill as discussed below. The non-expansive fill should consist of aggregate base rock or a clayey soil with a plasticity index of 15 or less.

Considering the potential for some movement of the surface soils, we expect that a reinforced slab will perform better than an unreinforced slab. Consideration should also be given to using a control joint spacing on the order of 2 feet in each direction for each inch of slab thickness.

Exterior Flatwork

Concrete walkways and exterior flatwork should be at least 4 inches thick and should be constructed on at least 6 inches of Class 2 aggregate base. To improve performance, exterior slabs-on-grade, such as for patios, may be constructed with a thickened edge to improve edge stiffness and to reduce the potential for water seepage under the edge of the slabs and into the underlying base and subgrade. In our opinion, the thickened edges should be at least 8 inches wide and ideally should extend at least 4 inches below the bottom of the underlying aggregate base layer.

Interior Slabs

At-grade concrete slab-on-grade floors should be constructed on a layer of non-expansive fill at least 6 inches thick. Recycled aggregate base should not be used for non-expansive fill below interior slabs-on-grade, since adverse vapor could occur from crushed asphalt components.

In areas where dampness of concrete floor slabs would be undesirable, such as within the building interior, concrete slabs should be underlain by at least 6 inches of free-draining gravel, such as ½- to ¾-inch clean crushed rock with no more than 5 percent passing the ASTM No. 200 sieve. Pea gravel should not be used for this capillary break material. The crushed rock layer should be densified and leveled with vibratory equipment, and may be considered as the non-expansive fill.

To reduce vapor transmission up through at-grade concrete floor slabs, the crushed rock section should be covered with a high quality vapor barrier conforming to the requirements of ASTM E 1745 Class A, with a water vapor transmission rate less than or equal to 0.01 perms (such as 15-mil thick “Stego Wrap Class A”) should be used. The vapor barrier should be placed directly below the concrete slab. Sand above the vapor barrier is not recommended. The vapor barrier should be installed in accordance with ASTM E 1643. All seams and penetrations of the vapor barrier should be sealed in accordance with manufacturer’s recommendations.

Please note that the basement mat should be underlain by a high-quality waterproofing membrane selected by your waterproofing consultant.

The permeability of concrete is affected significantly by the water:cement ratio of the concrete mix, with lower water:cement ratios producing more damp-resistant slabs and stronger concrete. Where moisture protection is important and/or where the concrete will be placed directly on the vapor barrier, the water:cement ratio should be 0.45 or less. To increase the workability of the concrete, mid-range plasticizers can be added to the mix. Water should not be added to the concrete mix unless the slump is less than specified and the water:cement ratio will not exceed 0.45. Other steps that may be taken to reduce moisture transmission through the concrete slabs-on-grade include moist curing for 5 to 7 days and allowing the slab to dry for a period of two months or longer prior to placing floor coverings. Also, prior to installation of the floor covering, it may be appropriate to test the slab moisture content for adherence to the manufacturer’s requirements and to determine whether a longer drying time is necessary.

Structural Slabs

As an alternative, since drilled piers will be used to support the at-grade areas (particularly at the garage), it may be more practical and easier to construct the garage slabs as structural slabs supported on the on the pier foundations with a 2-inch minimum void form used below the slabs. If this alternative is selected, the non-expansive fill recommended above may be eliminated.

At the interior areas where floor dampness is a concern, such as the garage, a water-proofing membrane that will adhere to the concrete (such as preproof or polygard) should be placed between the void form and mat, rather than a vapor barrier. The contractor will need to exercise care to maintain the integrity of the void forms while placing reinforcing steel and concrete.

Subsurface Drainage

Although it is unlikely that static ground water will rise to the level of the basement floor, due to the possibility of perched water conditions and surface water infiltration, an optional subsurface drain system could be installed below the basement mat to reduce the possibility of water pressure developing below the mat and floor damp-proofing system.

If installed, the perforated pipes for the below grade drainage system should be installed at the bottom of the basement excavation. The basement drainage system should include a minimum 4- to 8-inch-thick blanket of free-draining gravel, such as 1/2- or 3/4-inch crushed rock with no more than 5 percent passing the ASTM No. 200 sieve, below the basement mat. Prior to placing the gravel blanket, the subgrade below the gravel layer should be surface compacted and covered with a filter fabric, such as TC Mirafi 140N. The gravel drain should extend up and around the sides of the mat and basement walls.

Drain pipes around the basement walls should consist of 4-inch diameter perforated PVC pipes with perforations placed down installed at bottom of the wall excavation. The perforated pipes should discharge to a suitable sump and pump system or daylight to a landscaping area by gravity flow. To minimize vapor transmission through the basement mat, a high-quality water-proof membrane should be placed over the crushed rock and around the edges of the mat foundation. A conceptual schematic sketch of the basement drainage system is presented in Figure 9.

DRIVEWAY PAVEMENT

For light residential type traffic, if the driveway will be constructed using asphalt concrete, we recommend the driveway pavement section consist of at least 2.5 inches of asphalt concrete on at least 8 inches of Class 2 aggregate base. However, if occasional heavy truck traffic is expected, the aggregate base section should be increased to at least 10 to 12 inches thick.

If the driveway will be constructed with Portland cement concrete (PCC), we recommend the driveway pavement consist of at least 5 inches of PCC on at least 8 inches of Class 2 aggregate base. Un-reinforced concrete for the 5-inch-thick driveway pavement should have a 28-day compressive strength of at least 3,500 psi. PCC pavements should be laterally constrained with curbs or shoulders and sufficient control joints should be incorporated in the design and construction to limit and control cracking.

The soil subgrade and aggregate base below the pavement section should be prepared and compacted as recommended below. The use of a moisture cut-off or thickened edge along the edges of the driveway would be desirable in order to reduce water seepage below the edges of the driveway and into the underlying aggregate base and subgrade, which can lead to premature pavement distress.

CONCRETE PAVERS

If pavers will be used for the proposed driveway, we recommend that interlocking pavers or paving stones for vehicle traffic have a thickness of at least 75 mm, have sufficient edge restraint, such as provided by a concrete curb, and be installed in accordance with the manufacturer's specifications and instructions. For light residential type traffic, we recommend that the pavers be constructed on at least 8 inches of Class 2 aggregate base and increased to at least 10 to 12 inches thick if occasional heavy truck traffic is expected.

If it is desired to increase the service life of the pavers/paving stones and decrease the potential for differential movements, the subgrade below the aggregate base layer may be reinforced with a woven stabilization fabric, such as TC Mirafi 500X, or a geogrid, such as Tensar BX1100 or TX140. Geogrids have a higher tensile strength and usually provide greater subgrade reinforcement promoting longer pavement service life than do geotextiles.

EARTHWORK

Clearing and Subgrade Preparation

All deleterious materials, such as existing foundations, slabs, pavements, utilities to be abandoned, vegetation, surface fills, loose or soft soils, root systems, topsoil, etc. should be cleared from areas to be built on or paved. The actual stripping depth should be determined by a member of our staff at the time of construction. Excavations that extend below finish grade should be backfilled with structural fill that is water-conditioned, placed, and compacted as recommended in the section titled "Compaction."

After the site has been properly cleared, stripped, and excavated to the required grades, exposed soil surfaces in areas to receive structural fill or slabs-on-grade should be scarified to a depth of 6 inches, moisture conditioned, and compacted as recommended for structural fill in the section titled "Compaction."

Please note that large fills are generally not desirable on a hillside site like this. However, if fills are to be constructed on natural slopes (not retained by retaining walls) having an inclination steeper than 6 horizontal to 1 vertical, the fill should be benched, and a key excavated into the underlying bedrock. Subdrains should be installed during the grading as required by our representative in the field. If significant fills are planned, we should be contacted to evaluate their feasibility and for specific recommendations.

Temporary Slopes and Excavations

The contractor should be responsible for the design and construction of all temporary slopes and any required shoring. Shoring and bracing should be provided in accordance with all applicable local, state and federal safety regulations, including the current OSHA excavation and trench safety standards.

Because of the potential for variation of the on-site soils, field modification of temporary slopes may be required. Unstable materials encountered on slopes and trenches during and after excavation should be trimmed off even if this requires cutting the slopes back to a flatter inclination.

Protection of the structures near excavations and trenches will also be the responsibility of the contractor. In our experience, a preconstruction survey is generally performed to document existing conditions prior to construction, with intermittent monitoring of the structures during construction.

Material For Fill

All on-site soil containing less than 3 percent organic material by weight (ASTM D2974) should be suitable for use as structural fill. Structural fill should not contain rocks or pieces larger than 6 inches in greatest dimension and no more than 15 percent larger than 2.5 inches. Imported non-expansive fill should have a Plasticity Index no greater than 15, should be predominately granular, and should have sufficient binder so as not to slough or cave into foundation excavations and utility trenches. Recycled aggregate base should not be used for non-expansive fill at building interior. A member of our staff should approve proposed import materials prior to their delivery to the site.

Compaction

Scarified soil surfaces and all structural fill should be compacted in uniform lifts no thicker than 8 inches in pre-compacted thickness, conditioned to the appropriate moisture content, and compacted as recommended for structural fill in Table 3 below. The relative compaction and moisture content recommended in Table 3 is relative to ASTM Test D1557, latest edition.

**Table 3. Compaction Recommendations
Awbrey 2-Lot Development
Portola Valley, California**

<u>General</u>	<u>Relative Compaction*</u>	<u>Moisture Content*</u>
• Scarified subgrade in areas to receive structural fill.	90 percent	Above optimum
• Structural fill composed of native soil.	90 percent	Above optimum
• Structural fill composed of non-expansive fill.	90 percent	Above optimum
• Structural fill below a depth of 4 feet.	93 percent	Above optimum
<u>Pavement Areas</u>		
• Upper 6-inches of soil below baserock.	95 percent	Above optimum
• Aggregate baserock.	95 percent	Near optimum
<u>Utility Trench Backfill</u>		
• On-site soil.	90 percent	Above optimum
• Imported sand	95 percent	Near optimum

* Relative to ASTM Test D1557, latest edition.

At the start of site grading and earthwork construction, and prior to subgrade preparation and placement of non-expansive fill, representative samples of on-site soil and import material will need to be collected in order for a laboratory compaction test to be performed for use during on-site density testing. Sampling of on-site soil and proposed import material should be requested by the contractor at least 5 days prior to when our staff will be needed for density testing to allow time for soil sampling and laboratory testing to be performed prior to our on-site compaction testing.

Finished Slopes

We recommend that finished slopes be cut or filled to an inclination preferably no steeper than 2.5:1 (horizontal:vertical). Exposed slopes may be subject to minor sloughing and erosion that could require periodic maintenance. We recommend that all slopes and soil surfaces disturbed during construction be planted to with erosion-resistant vegetation.

Surface Drainage

Finished grades should be designed to prevent ponding of water and to direct surface water runoff away from foundations, and edges of slabs and pavements, and toward suitable collection and discharge facilities. Slopes of at least 2 percent are recommended for flatwork and pavement areas with 5 percent preferred in landscape areas within 8 feet of the structures, where possible. At a minimum, splash blocks should be provided at the discharge ends of roof downspouts to carry water away from perimeter foundations. Preferably, roof downspout water should be collected in a closed pipe system that is routed to a storm drain system or other suitable location.

Drainage facilities should be observed to verify that they are adequate and that no adjustments need to be made, especially during the first two years following construction. We recommend preparing an as-built plan showing the locations of surface and subsurface drain lines and clean-outs. The drainage facilities should be periodically checked to verify that they are continuing to function properly. It is likely the drainage facilities will need to be periodically cleaned of silt/debris that may build up in the lines.

FUTURE SERVICES

Plan Review

Romig Engineers should review the completed structural and civil plans for conformance with the recommendations contained in this report. We should be provided with these plans as soon as possible upon completion in order to limit the potential for delays in the permitting process that might otherwise be attributed to our review process. In addition,



it should be noted that many of the local building and planning departments now require “clean” geotechnical plan review letters prior to acceptance of plans for their final review. Since our plan reviews typically do result in recommendations for additional changes to the plans, our generation of a “clean” review letter often requires two iterations.

At a minimum, we recommend the following note be added to the plans: “Earthwork, pier drilling, basement excavation, retaining wall drainage and backfill, foundation construction, slab subgrade preparation, pavement construction, non-expansive fill placement, utility trench backfill and site drainage should be performed in accordance with the geotechnical report prepared by Romig Engineers, Inc., dated June 25, 2020. Romig Engineers should be notified at least 48 hours in advance of any earthwork or foundation construction and should observe and test during earthwork and foundation construction as recommended in the geotechnical report. Romig Engineers should be notified at least 5 days prior to earthwork, trench backfill and subgrade preparation work to allow time for sampling of on-site soil and laboratory compaction curve testing to be performed prior to on-site compaction density testing.”

Construction Observation and Testing

All earthwork and foundation construction should be observed and tested by us to 1) establish that subsurface conditions are compatible with those used in the analysis and design; 2) observe compliance with the design concepts, specifications and recommendations; and 3) allow design changes in the event that subsurface conditions differ from those anticipated. The recommendations in this report are based on a limited number of borings. The nature and extent of variation across the site may not become evident until construction. If variations are exposed during construction, it will be necessary to reevaluate our recommendations.



REFERENCES

Aerial Photographs

United States Geologic Survey Library, Menlo Park, California (USGS); WAC Corporation, Eugene, Oregon (WAC); Fairchild Aerial Photography Collection, Whittier College (Fair); and Pacific Aerial Surveys, Oakland, California (PAS): black and white vertical stereo pairs, except as noted.

Source	Imagery	Date	Scale
PAS	AV-170-19-22/23	6/8/55	1:10,000
PAS	AV-432-16-21/22	5/8/61	1:12,000
PAS	AV-1045-17-23/24	5/2/72	1:12,000
PAS	AV-1497-01-06/07	5/8/78	1:33,500
WAC	88CA-29-92/93	9/12/88	1:31,500
PAS	SMT-AV-6600-16-20/21	6/26/00	1:12,000
PAS	KAV-9010-105-1/2	3/16/05	1:10,000
PAS	KAV-9200-63-2/3	10/21/05	1:7,200

Plans

Westfall Engineers, Inc, August 2019, Topographic Map of 1061 Los Trancos Road, Portola Valley, CA, Scale 1:10

Consultant Reports

Baldwin Consultants, 1985, Geotechnical Investigation, Vista Verde Landslide Area, San Mateo County, California, report dated November 29, 1985.

Harlan Tait Associates, 1993, Geologic and Seismic Conditions and Geotechnical Design Criteria for Mitigation Measures, Prepared for Blue Oaks Subdivision, Portola Valley, California, report dated May 26, 1993.

Harlan Tait Associates, 1997, Geotechnical Investigation, Blue Oaks Subdivision, Portola Valley, California, report dated December 19, 1997.

Hoexter Consulting, Inc, 2003, Fault Rupture Hazard Investigation, Geologic Hazard Reconnaissance, Bender Residence Addition, 1065 Los Trancos Road, Portola Valley (unincorporated San Mateo County, California), report dated September 28, 2003.

JCP Geologists-Engineers, 1981, Geologic and Soil & Foundation Studies for Property Located at 130 Foxwood Road, Los Trancos Woods, San Mateo County, California, report dated September 2, 1981.

Louis A. Richardson, C.E.G., 1990, Special Studies Zone Investigation, 1144 Los Trancos Road, San Mateo County, California, report dated August 23, 1990.

Murray Engineers Inc., 2014, Engineering Geologic and Geotechnical Investigation Proposed Residence APN 080-082-040, Los Trancos Road, San Mateo County, California, report dated November 2014.

Steven F. Connelly, C.E.G., 2000, Engineering Geologic Investigation, Proposed Addition, Vaughn Residence, 445 Ramona Road, San Mateo County, California, report dated October 4, 2000.

Steven F. Connelly, C.E.G., 2002, Engineering Geologic Investigation, Baron Property, 1036 Los Trancos Road, San Mateo County, California"

Romig Engineers, Inc., 2008, Geologic and Fault Rupture Hazard Investigation for Weiss Residence, 124 Foxwood Road, Los Trancos Woods, Portola Valley, California, report dated February 2008.

Upp Geotechnology, Inc., 1996, Fault Location and Geotechnical Investigation, Lands of Wickersham, 1227 Los Trancos Road, San Mateo County, California, report dated November 14, 1996.

Upp Geotechnology, Inc., 2000, Limited Geotechnical Investigation, Lands of Weiss, 124 Foxwood Road, San Mateo County, California, report dated April 18, 2000.

Publications

Aagaard, B.T., Blair, J.L., Boatwright, J., Garcia, S.H., Harris, R.A., Michael, A.J., Schwartz, D.P., and DiLeo, J.S., 2016, Earthquake Outlook for the San Francisco Bay Region 2014-2043 (ver. 1.1, August 2016): U.S. Geological Survey Fact Sheet 2016-3020, 6 p., [http](http://).

Al Atik, L., and Sitar, N., 2010, Seismic Earth Pressures on Cantilever Retaining Structures, Journal of Geotechnical and Geoenvironmental Engineering, ASCE Vol. 136, No. 10.

American Society of Civil Engineers, 2016, Minimum Design Loads for Buildings and Other Structures, ASCE Standard 7-16.

Brabb, Earl E. and Pampeyan, Earl H., 1972, Preliminary Map of Landslide Deposits in San Mateo County, California, U.S. Geological Survey Map MF-344, Map Scale 1:62,500.

Brabb, E.E, and Olson, Jean A, 1986, Map Showing Faults and Earthquake Epicenters in San Mateo County, California, USGS Miscellaneous Investigations Series Map I-1257F, scale 1:62,500.

Brabb, E.E., Graymer, R.W., and Jones, D.L., 1998, Geology of the Onshore Part of San Mateo County, California: A Digital Database; USGS OF 98-137.



Brabb, E.E., Graymer, R.W., and Jones, D.L., 2000, Geologic Map and Database of the Palo Alto 30 X 60 Minute Quadrangle, California, U.S. Geological Survey Miscellaneous Field Studies Map 2332, Map Scale 1: 100,000.

California Building Standards Commission, and International Code Council, 2019 California Building Code, California Code of Regulations, Title 24, Part 2.

California Department of Conservation, Division of Mines and Geology (DMG), 1994, Fault-Rupture Hazard Zones in California, Special Publication 42.

California Department of Conservation, 2008, Probabilistic Seismic Hazards Mapping Ground Motion Page, <https://www.conservation.ca.gov/cgs/ground-motion-interpolator>.

California Division of Mines and Geology, 1974, State of California Special Studies Zones, Mindogo Hill Quadrangle, Map Scale 1:24,000 (1 inch = 2000 feet).

California Geological Survey, 2005, Seismic Hazard Zone Report for the Mindogo Hill 7.5-Minute Quadrangle, Santa Clara and San Mateo Counties, California, Seismic Hazard Zone Report 109.

Leighton Associates, 1976, Geotechnical Hazard Synthesis Map, San Mateo County, California, Planning Department, San Mateo County, California, Scale 1:24,000.

Lew, M., Al Atik, L., Sitar, N., Pourzanjani, M., & Hudson, M., 2010, Seismic Earth Pressures on Deep Building Basements, SEAOC 2010 Convention Proceedings.

Spittler, T.E, et al, 1990, Landslide Features and Other Coseismic Fissures Triggered by the Loma Prieta Earthquake, Central Santa Cruz Mountains, California, in McNutt, S.R, and Sydnor, R.H, The Loma Prieta (Santa Cruz Mountains), California, Earthquake of 17 October 1989, CDMG SP 104.



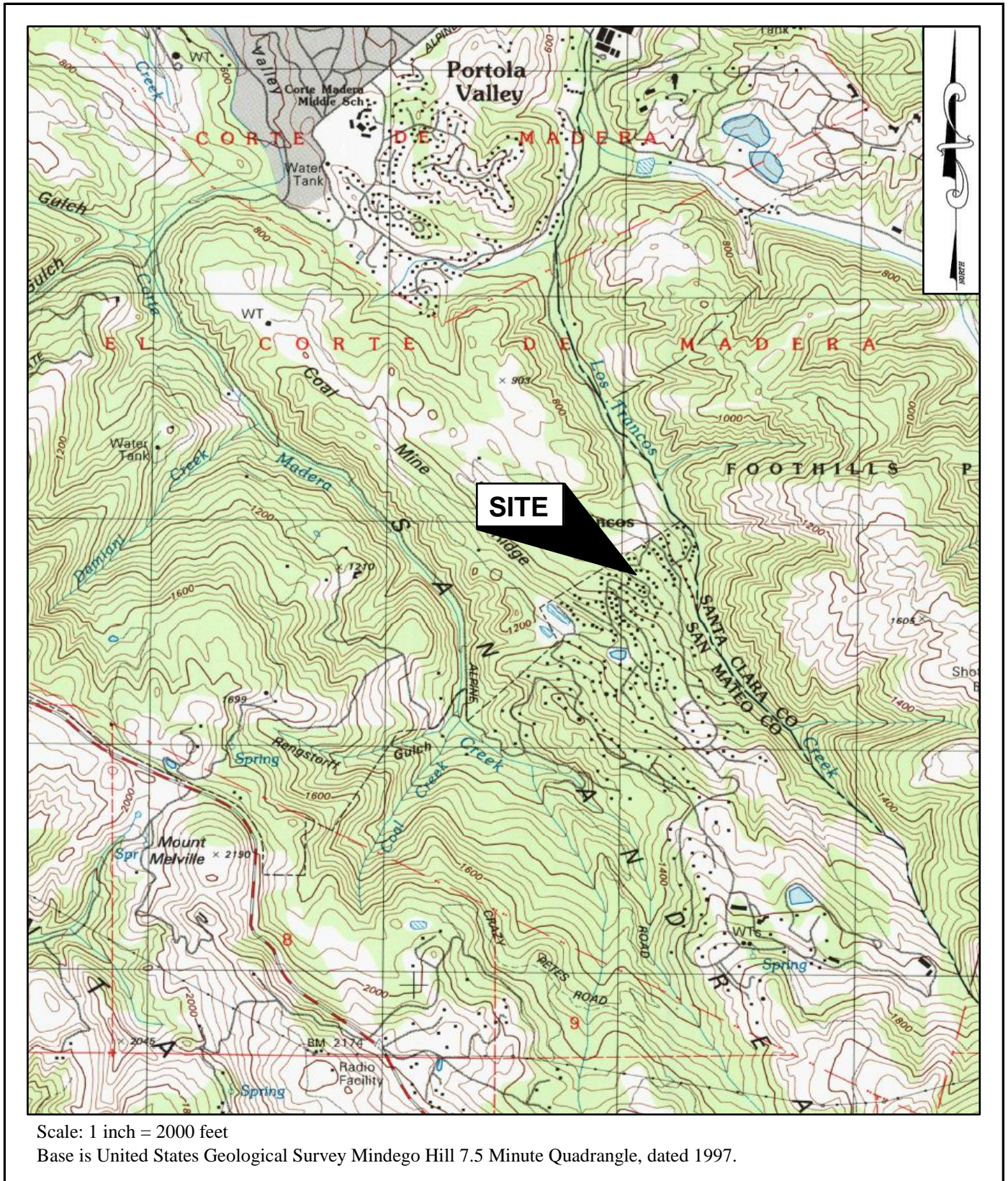







VICINITY MAP
 AWBREY 2-LOT DEVELOPMENT
 PORTOLA VALLEY, CALIFORNIA

FIGURE 1
 JUNE 2020
 PROJECT NO. 5082-1

LEGEND

- EB-4**  Approximate Locations of Exploratory Borings
-  Approximate Location of Fault Trench T-1 (Romig Engineers, 2020)
-  Approximate Location of Fault Trench (Hoexter Consulting, 2003)
-  Approximate Locations of Cross Sections (Figure 6)
- Qa** Artificial Fill
- Rs** Residual Soil derived from underlying Santa Clara Formation
-  Limits of Possible Former Landslide
-  Location of Planned Building Footprint
-  Outline of Existing Structures

Note: No indication of settlement or lateral movement was observed in existing structures.

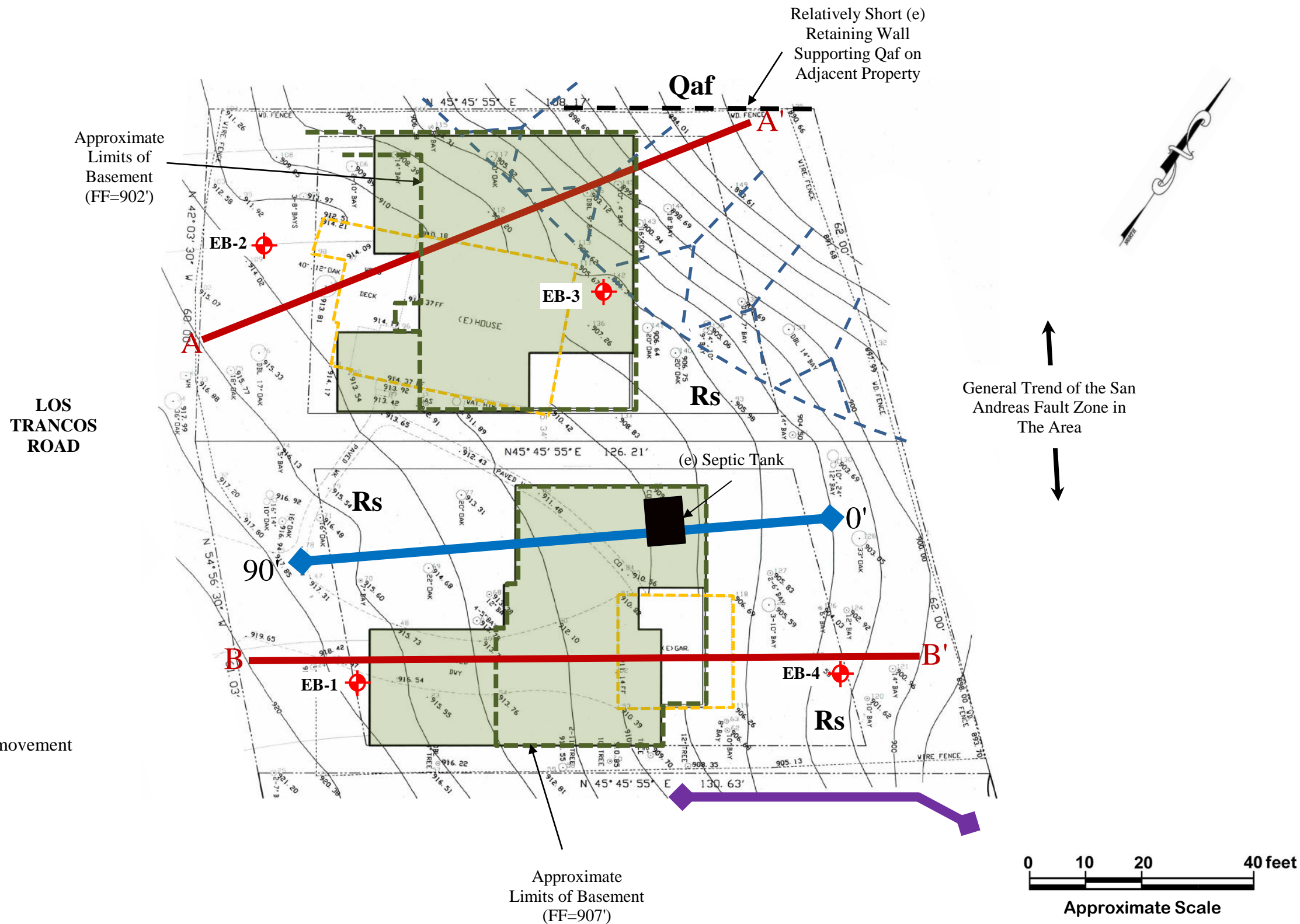

Approximate Scale: 1 inch = 20 feet.

Base is site plan prepared by Westfall Engineers, Inc., August 2019.

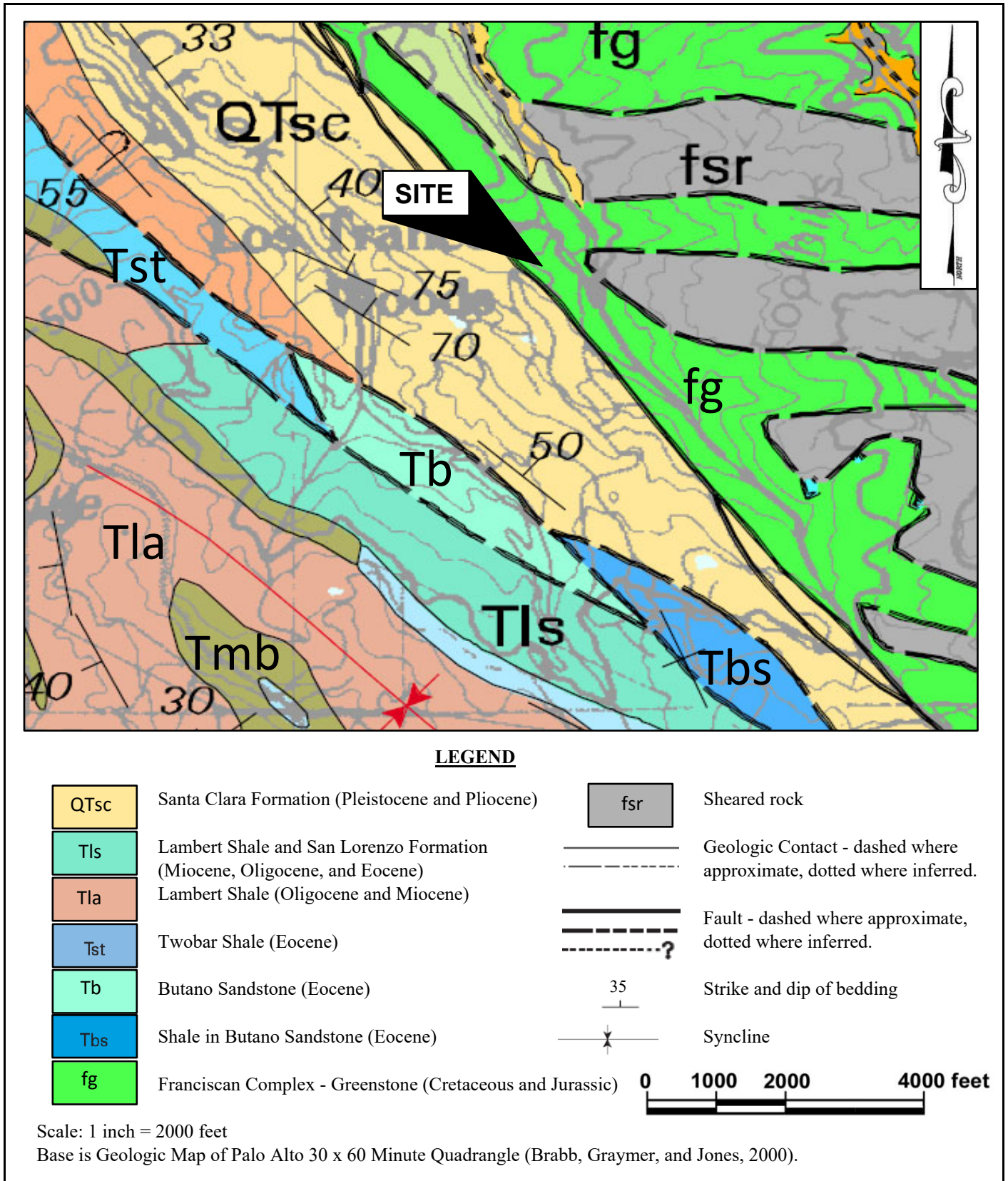

VICINITY GEOLOGIC MAP
 AWBREY 2-LOT DEVELOPMENT
 PORTOLA VALLEY, CALIFORNIA

FIGURE 3
 JUNE 2020
 PROJECT NO. 5082-1

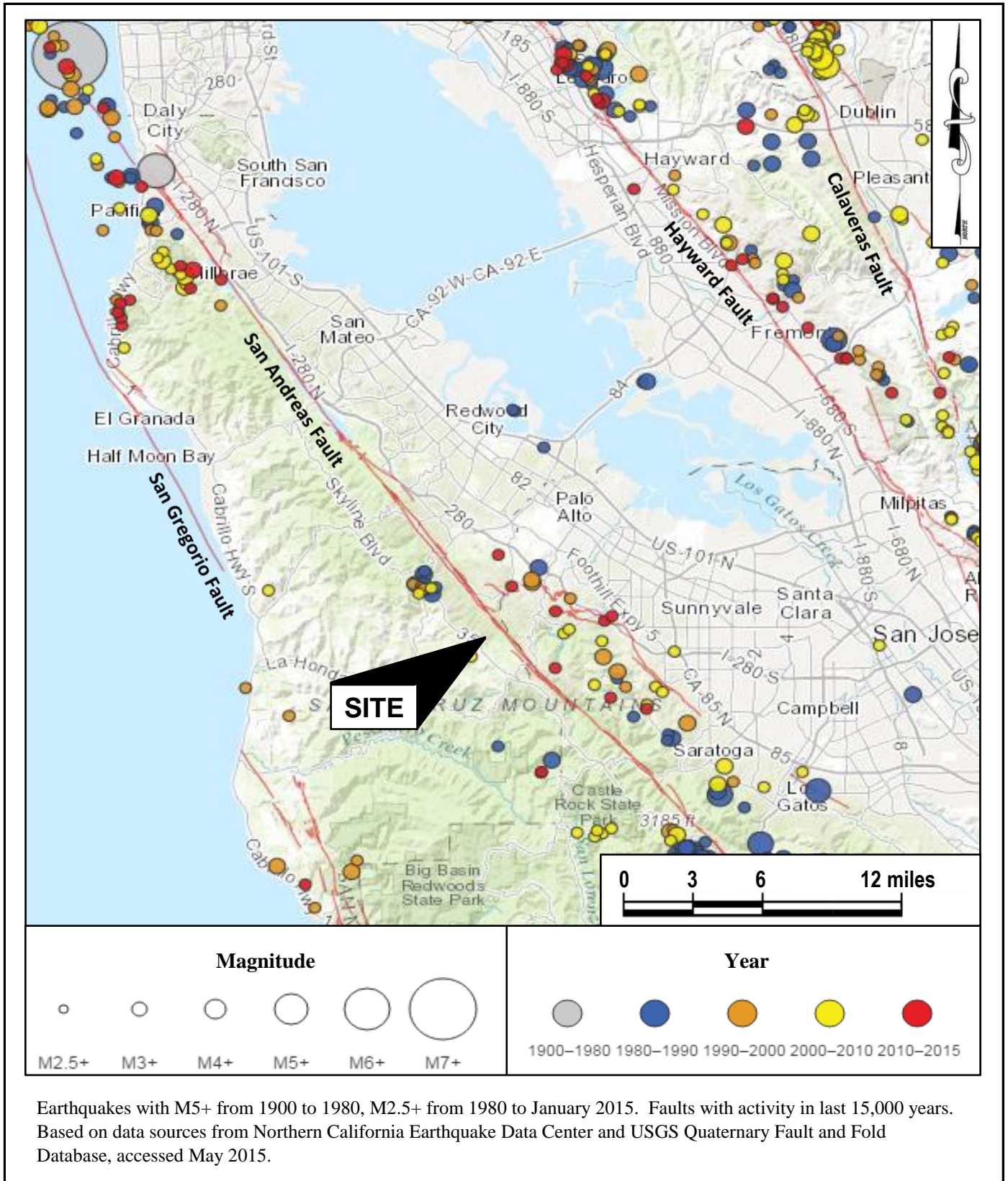

REGIONAL FAULT AND SEISMICITY MAP
 AWBREY 2-LOT DEVELOPMENT
 PORTOLA VALLEY, CALIFORNIA

FIGURE 4
 JUNE 2020
 PROJECT NO. 5082-1

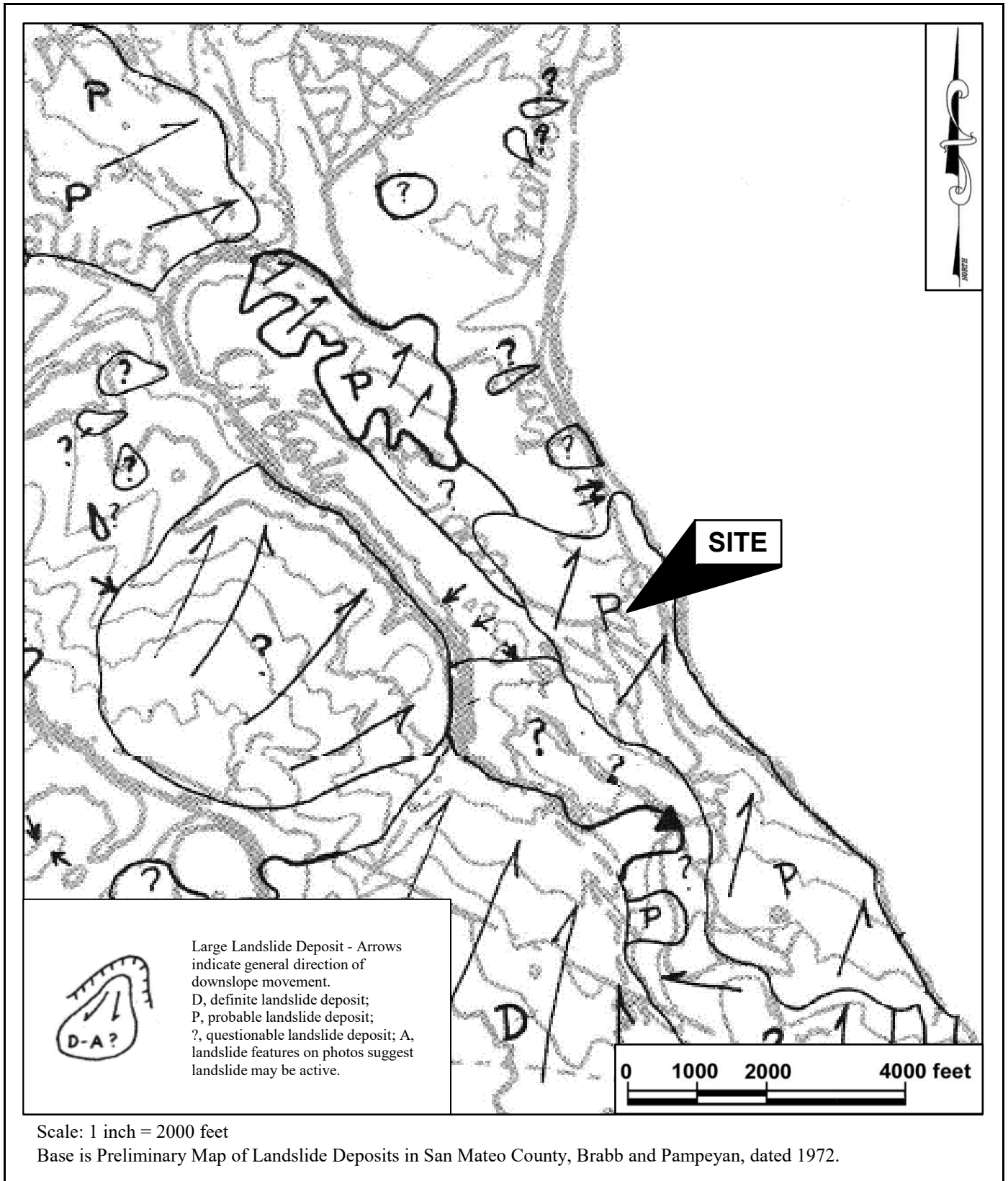

REGIONAL LANDSLIDE MAPPING
 AWBREY 2-LOT DEVELOPMENT
 PORTOLA VALLEY, CALIFORNIA

FIGURE 5
 JUNE 2020
 PROJECT NO. 5082-1

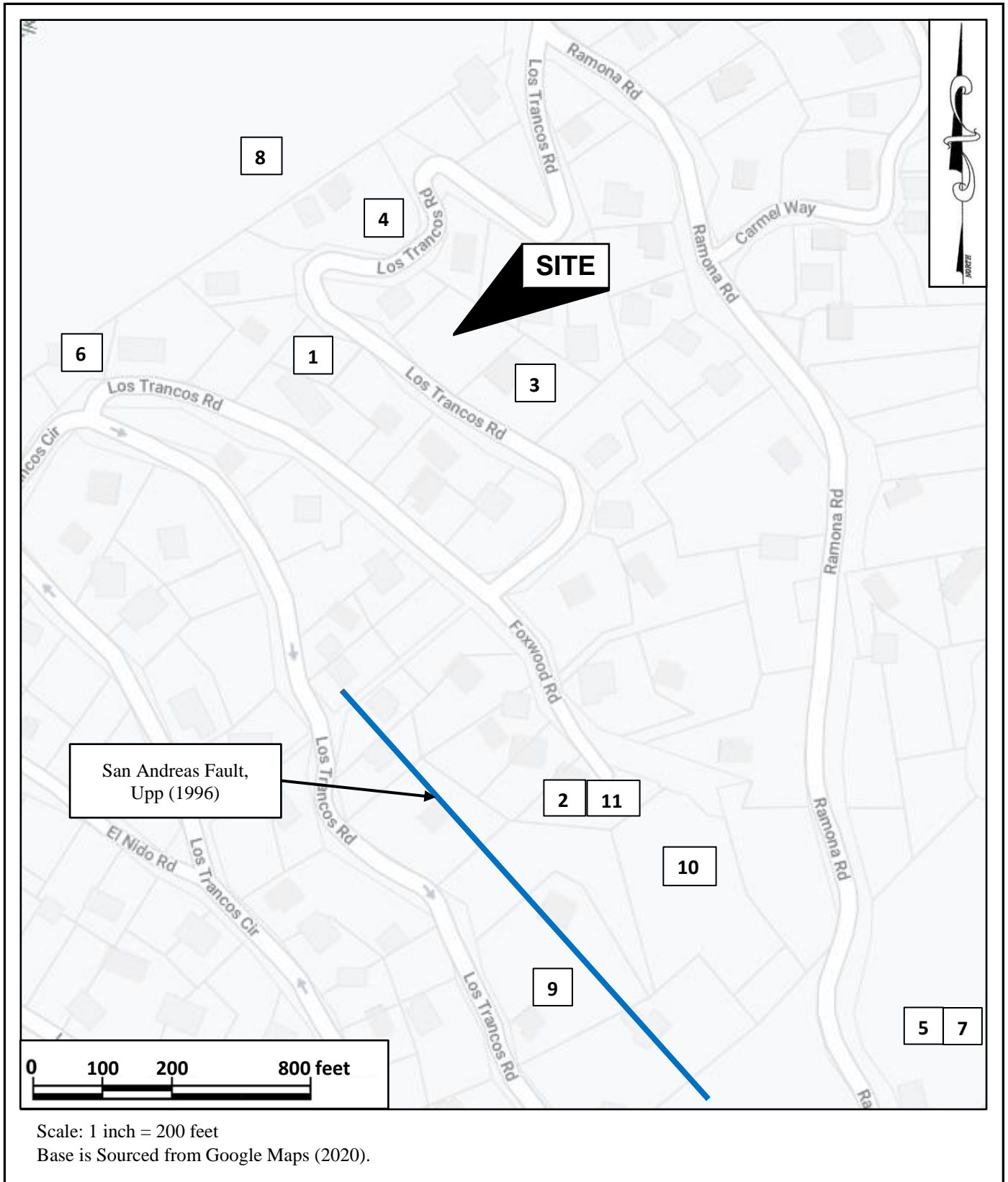

MAP OF NEARBY INVESTIGATIONS AND FAULT SPLAYS
 AWBREY 2-LOT DEVELOPMENT
 PORTOLA VALLEY, CALIFORNIA

FIGURE 6
 JUNE 2020
 PROJECT NO. 5082-1

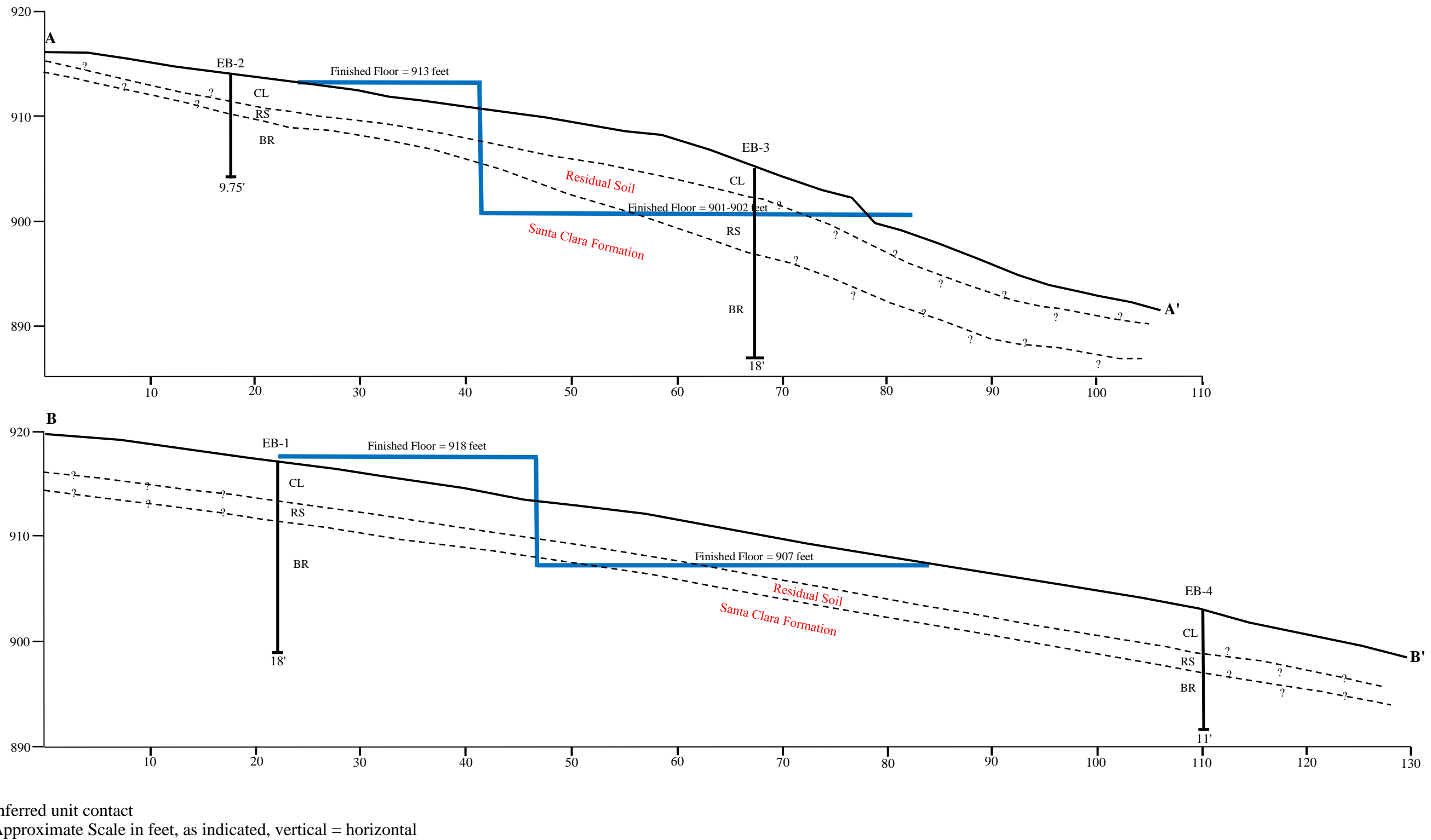

GEOLOGIC CROSS SECTIONS A-A' AND B-B'
 AWBREY 2-LOT DEVELOPMENT
 PORTOLA VALLEY, CALIFORNIA



FIGURE 7
 JUNE 2020
 PROJECT NO. 5082-1

FAULT TRENCH T-1 - Southeast wall
Trench Oriented N38°E

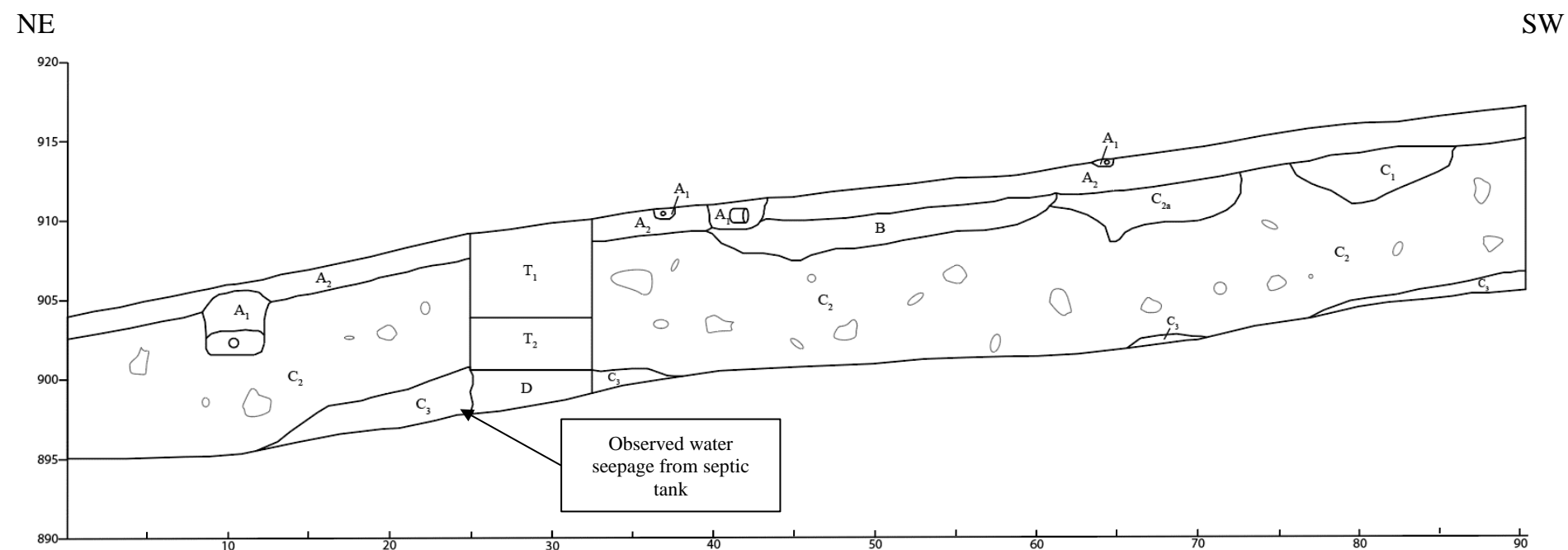

Explanation of Earth Materials

Surficial Soil

Unit A₁: Fill placed around and over pipes.

Unit A₂: **Colluvial soil**, Brown (10YR 5/3), Sandy Lean Clay, moist, fine to medium grained sand, fine gravel, low to moderate plasticity, abundant roots.

Unit B: **Residual Soil**, Dark Yellowish Brown (10YR 3/4), Sandy Lean Clay, moist, fine to coarse sand grains, fine gravel, moderate plasticity, some rock fragments.

Santa Clara Formation - Likely dislocated as part of deep-seated, dormant landslide, comprised of weathered claystone and conglomerate with a clayey matrix. Conglomerate contains fine to coarse sand, fine to coarse sub-angular to rounded gravels, as well as sub-rounded to rounded cobbles. Cobbles are comprised primarily of greenstone, claystone, siltstone, sandstone, as well as some volcanic welded tuff. Clay matrix is very stiff to hard.

Unit C₁: Dark Brown (10YR 3/3), CL, contains relatively few cobbles.

Unit C₂: Generally Brownish Yellow to Yellowish Brown (10YR 5/4, 5/6, 6/6, 6/8), CL, abundant cobbles of varying rock types.

Unit C_{2a}: Dark Yellowish Brown (10 YR 3/4), CL, similar composition to C₂ but with darker clay matrix.

Unit C₃: Yellowish Brown (10YR 5/6, 5/4, 4/6), CL, higher clay content, fewer coarse gravels, no cobbles observed

Unit D: Disturbed soil underneath septic tank. (derived from C₃)

Unit T₁: Concrete septic tank.

Unit T₂: Remnants of redwood septic tank.

Approximate scale in feet, as indicated, vertical = horizontal

Other Observations

- Shallower portions of Santa Clara Formation Units (C), are slightly softer and could possibly be called residual soil, hardness of material increases with depth.
- Observed areas with oxidation staining (likely Iron and Manganese Oxide) throughout the Santa Clara Formation.
- Did not observe any evidence of tectonically caused shearing or offsets.

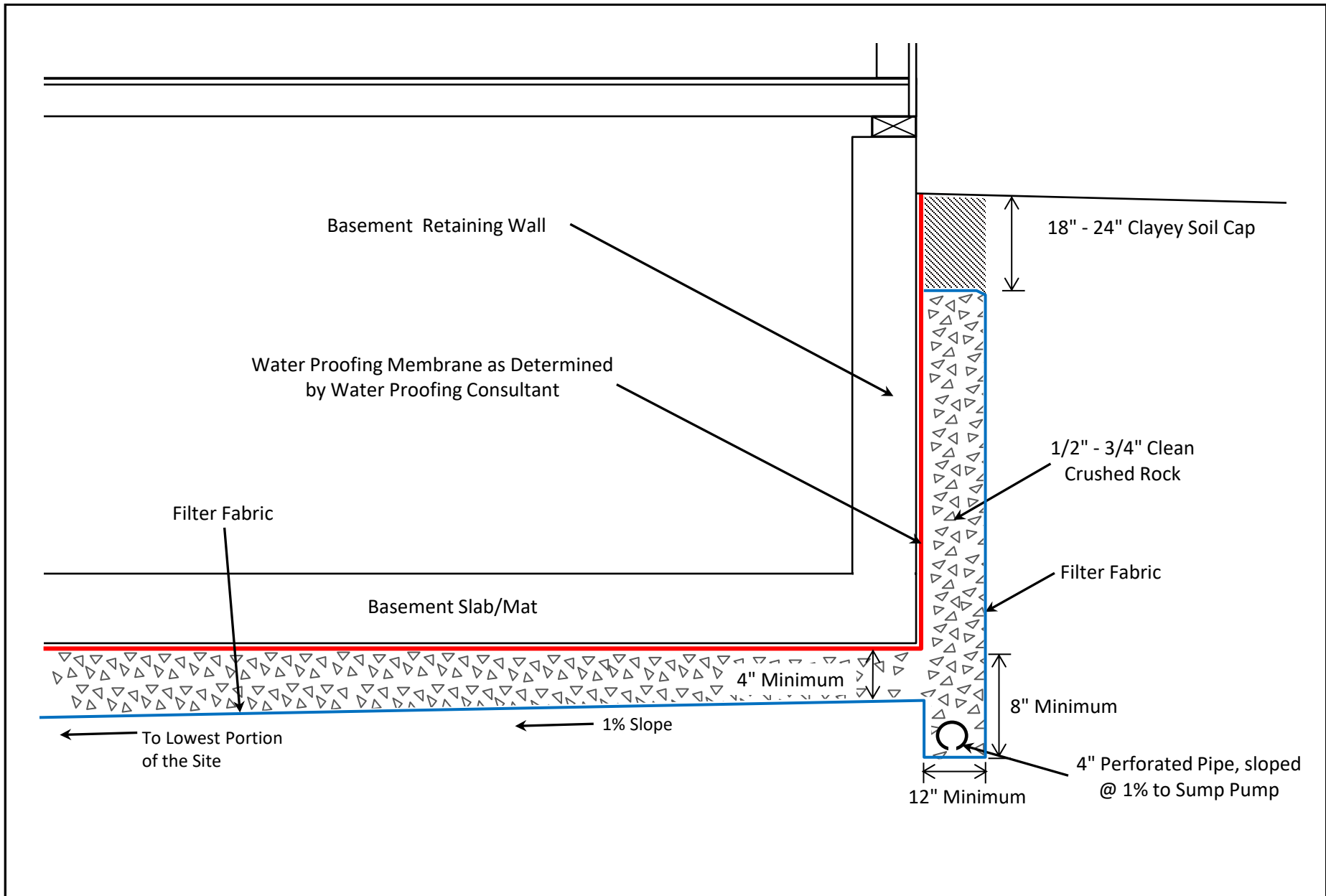

SUBSLAB DRAINAGE DETAIL
 AWBREY 2-LOT DEVELOPMENT
 PORTOLA VALLEY, CALIFORNIA

FIGURE 9
 JUNE 2020
 PROJECT NO. 5082-1



APPENDIX A

FIELD INVESTIGATION

The soils encountered during drilling were logged by our representative, and samples were obtained at depths appropriate to the investigation. The samples were taken to our laboratory where they were carefully observed and classified in accordance with the Unified Soil Classification System. The logs of our borings, and a summary of the soil classification system (Figure A-1) used on the boring logs are attached.

Several tests were performed in the field during drilling. The standard penetration resistance was determined by dropping a 140-pound hammer through a 30-inch free fall, and recording the blows required to drive the 2-inch (outside diameter) sampler 18 inches. The standard penetration resistance is the number of blows required to drive the sampler the last 12 inches, and is recorded on the boring logs at the appropriate depth. The results of these field tests are also presented on the boring logs. Soil samples were also collected using a 2.5-inch O.D. drive sampler. The blow counts shown on the logs for the 2.5-inch sampler do not represent SPT values and have not been corrected in any way.

The location of the exploratory borings and fault trench were established by pacing using the topographic survey prepared by Westfall Engineers, Inc., dated August 2019. The location of the borings and trench should be considered accurate only to the degree implied by the method used.

The boring and trench logs and related information depict our interpretation of subsurface conditions only at the specific location and time indicated. Subsurface conditions and ground water levels at other locations may differ from conditions at the locations where exploration was conducted. The passage of time may also result in changes in the subsurface conditions.



USCS SOIL CLASSIFICATION

PRIMARY DIVISIONS			SOIL TYPE	SECONDARY DIVISIONS
COARSE GRAINED SOILS (< 50 % Fines)	GRAVEL	CLEAN GRAVEL (< 5% Fines)	GW	Well graded gravel, gravel-sand mixtures, little or no fines.
			GP	Poorly graded gravel or gravel-sand mixtures, little or no fines.
		GRAVEL with FINES	GM	Silty gravels, gravel-sand-silt mixtures, non-plastic fines.
			GC	Clayey gravels, gravel-sand-clay mixtures, plastic fines.
	SAND	CLEAN SAND (< 5% Fines)	SW	Well graded sands, gravelly sands, little or no fines.
			SP	Poorly graded sands or gravelly sands, little or no fines.
		SAND WITH FINES	SM	Silty sands, sand-silt mixtures, non-plastic fines.
			SC	Clayey sands, sand-clay mixtures, plastic fines.
FINE GRAINED SOILS (> 50 % Fines)	SILT AND CLAY Liquid limit < 50%		ML	Inorganic silts and very fine sands, with slight plasticity.
			CL	Inorganic clays of low to medium plasticity, lean clays.
			OL	Organic silts and organic clays of low plasticity.
	SILT AND CLAY Liquid limit > 50%		MH	Inorganic silt, micaceous or diatomaceous fine sandy or silty soil.
			CH	Inorganic clays of high plasticity, fat clays.
			OH	Organic clays of medium to high plasticity, organic silts.
HIGHLY ORGANIC SOILS			Pt	Peat and other highly organic soils.
BEDROCK			BR	Weathered bedrock.

RELATIVE DENSITY

SAND & GRAVEL	BLOWS/FOOT*
VERY LOOSE	0 to 4
LOOSE	4 to 10
MEDIUM DENSE	10 to 30
DENSE	30 to 50
VERY DENSE	OVER 50

CONSISTENCY

SILT & CLAY	STRENGTH [^]	BLOWS/FOOT*
VERY SOFT	0 to 0.25	0 to 2
SOFT	0.25 to 0.5	2 to 4
FIRM	0.5 to 1	4 to 8
STIFF	1 to 2	8 to 16
VERY STIFF	2 to 4	16 to 32
HARD	OVER 4	OVER 32

GRAIN SIZES

BOULDERS	COBBLES	GRAVEL		SAND			SILT & CLAY
		COARSE	FINE	COARSE	MEDIUM	FINE	
12 "	3"	0.75"		4	10	40	200
SIEVE OPENINGS				U.S. STANDARD SERIES SIEVE			

Classification is based on the Unified Soil Classification System; fines refer to soil passing a No. 200 sieve.

* Standard Penetration Test (SPT) resistance, using a 140 pound hammer falling 30 inches on a 2 inch O.D. split spoon sampler; blow counts not corrected for larger diameter samplers.

[^] Unconfined Compressive strength in tons/sq. ft. as estimated by SPT resistance, field and laboratory tests, and/or visual observation.

KEY TO SAMPLERS

	Modified California Sampler (3-inch O.D.)
	Mid-size Sampler (2.5-inch O.D.)
	Standard Penetration Test Sampler (2-inch O.D.)

KEY TO EXPLORATORY BORING LOGS

AWBREY 2-LOT DEVELOPMENT
PORTOLA VALLEY, CALIFORNIA

FIGURE A-1

JUNE 2020
PROJECT NO. 5082-1



WEATHERING

Fresh

Rock fresh, crystals bright, few joints may show slight staining. Rock rings under hammer if crystalline.

Very Slight

Rock generally fresh, joints stained, some joints may show thin clay coatings, crystals in broken face show bright. Rock rings under hammer if crystalline.

Slight

Rock generally fresh, joints stained, and discoloration extends into rock up to 1 inch. Joints may contain clay. In granitoid rocks some occasional feldspar crystals are dull and discolored. Crystalline rocks ring under hammer.

Moderate

Significant portions of rock show discoloration and weathering effects. In granitoid rocks, most feldspars are dull and discolored; some are clayey. Rock has dull sound under hammer and shows significant loss of strength as compared with fresh rock.

Moderately Severe

All rock except quartz discolored or stained. In granitoid rocks, all feldspars dull and discolored and majority show kaolinization. Rock shows severe loss of strength and can be excavated with geologist's pick. Rock goes "clunk" when struck.

Severe

All rock except quartz discolored or stained. Rock "fabric" clear and evident, but reduced in strength to strong soil. In granitoid rocks, all feldspars kaolinized to some extent. Some fragments of strong rock usually left.

Very Severe

All rock except quartz discolored and stained. Rock "fabric" discernible, but mass effectively reduced to "soil" with only fragments of strong rock remaining.

Complete

Rock reduced to "soil". Rock fabric not discernible or discernible only in small scattered locations. Quartz may be present as dikes or stringers.

HARDNESS

Very hard

Cannot be scratched with knife or sharp pick. Hand specimens requires several hard blows of geologist's.

Hard

Can be scratched with knife or pick only with difficulty. Hard blow of hammer required to detach hand specimen.

Moderately Hard

Can be scratched with knife or pick. Gouges or grooves to 1/4 inch deep can be excavated by hard blow of point of a geologist's pick. Hard specimen can be detached by moderate blow.

Medium

Can be grooved or gouged 1/16 inch deep by firm pressure on knife or pick point. Can be excavated in small chips to pieces about 1 inch maximum size by hard blows of the point of a geologist's pick.

Soft

Can be gouged or grooved readily with knife or pick point. Can be excavated in chips to pieces several inches in size by moderate blows of a pick point. Small thin pieces can be broken by finger pressure.

Very Soft

Can be carved with knife. Can be excavated readily with point of pick. Pieces 1 inch or more in thickness can be broken with finger pressure. Can be scratched readily by fingernail.

JOINT BEDDING AND FOLIATION SPACING

Spacing	Joints	Bedding and Foliation
Less than 2 in.	Very Close	Very Thin
2 in. to 1 ft.	Close	Thin
1 ft. to 3 ft.	Moderately Close	Medium
3 ft. to 10 ft.	Wide	Thick
More than 10 ft.	Very Wide	Very Thick

ROCK QUALITY DESIGNATOR (RQD)









RQD, as a percentage	Descriptor
Exceeding 90	Excellent
90 to 75	Good
75 to 50	Fair
50 to 25	Poor
Less than 25	Very Poor

DRILL TYPE: Minuteman with 3-1/4" Continuous Flight Auger

LOGGED BY: AS

DEPTH TO GROUND WATER: Not Encountered SURFACE ELEVATION: 918 feet

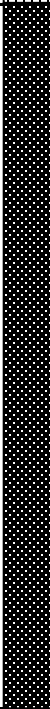
DATE DRILLED: 2/28/20

CLASSIFICATION AND DESCRIPTION	SOIL CONSISTENCY/ DENSITY or ROCK HARDNESS* (Figure A-2)	SOIL TYPE	SOIL SYMBOL	DEPTH (FEET)	SAMPLE INTERVAL	PEN. RESISTANCE (Blows/ft)			UNCONFIN. COMP. (TSF)*
						WATER CONTENT (%)	SHEAR STRENGTH (TSF)*		
Brown, Sandy Lean Clay, moist, fine to coarse grained sand, trace fine gravel, low plasticity, rock fragments, some roots.	Firm	CL		0		7	15		1.8
Light brown, Sandy Lean Clay, moist, fine to coarse grained sand, fine sub-angular to sub-rounded gravel, low plasticity, rock fragments, some roots. ■ Liquid Limit = 32, Plasticity Index = 14.	Very Stiff	CL				17	15		2.5
Residual Soil: Light brown, Sandy Lean Clay, moist, fine to coarse grained sand, fine sub-angular to sub-rounded gravel, low plasticity, many rock fragments.	Stiff	CL		5		13	9		
<p>Santa Clara Formation: Tan, orange, and brown, Sandstone and Siltstone, severely weathered, friable, conglomeratic.</p> <p>Note: The stratification lines represent the approximate boundary between soil and rock types, the actual transition may be gradual.</p> <p>*Measured using Torvane and Pocket Penetrometer devices.</p> <p>Increase in silt and clay content in rock.</p>	Soft to Very Soft	BR				22	9		
				10		43	7		
						60	8		
				15		54	9		
	42	13							
Bottom of Boring at 18 feet.				20					

EXPLORATORY BORING LOG EB-1
 AWBREY 2-LOT DEVELOPMENT
 PORTOLA VALLEY, CALIFORNIA

BORING EB-1
 JUNE 2020
 PROJECT NO. 5082-1









DRILL TYPE: Minuteman with 3-1/4" Continuous Flight Auger

LOGGED BY: AS

DEPTH TO GROUND WATER: Not Encountered SURFACE ELEVATION: 913 feet

DATE DRILLED: 2/28/20

CLASSIFICATION AND DESCRIPTION	SOIL CONSISTENCY/ DENSITY or ROCK HARDNESS* (Figure A-2)	SOIL TYPE	SOIL SYMBOL	DEPTH (FEET)	SAMPLE INTERVAL	PEN. RESISTANCE (Blows/ft)		WATER CONTENT (%)	SHEAR STRENGTH (TSF)*	UNCONFIN. COMP. (TSF)*
Dark brown, Sandy Lean Clay, moist, fine to coarse grained sand, low plasticity, trace gravel, rock fragments, some roots.	Stiff	CL		0						
						12	15	2.5		
Residual Soil: Light brown, Sandy Lean Clay, moist, fine to coarse grained sand, fine sub-angular to sub-rounded gravel, low plasticity, many rock fragments.	Hard	CL				60	7		>4.5	
Santa Clara Formation: Brown to orange-brown, Sandstone and Shale, and greenstone, very severely weathered, friable, orange mottling. Increase in sandstone and siltstone, color becomes lighter.	Very Soft to Soft	BR		5						
						62	11			
						50/4"	7			
						65	12			
						10	50/5"	10		
Bottom of Boring at 9.75 feet.										
Note: The stratification lines represent the approximate boundary between soil and rock types, the actual transition may be gradual. *Measured using Torvane and Pocket Penetrometer devices.				15						
					20					

EXPLORATORY BORING LOG EB-2
 AWBREY 2-LOT DEVELOPMENT
 PORTOLA VALLEY, CALIFORNIA

BORING EB-2
 JUNE 2020
 PROJECT NO. 5082-1







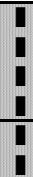

DRILL TYPE: Minuteman with 3-1/4" Continuous Flight Auger

LOGGED BY: AS

DEPTH TO GROUND WATER: Not Encountered SURFACE ELEVATION: 906 feet

DATE DRILLED: 2/28/20

CLASSIFICATION AND DESCRIPTION	SOIL CONSISTENCY/ DENSITY or ROCK HARDNESS* (Figure A-2)	SOIL TYPE	SOIL SYMBOL	DEPTH (FEET)	SAMPLE INTERVAL	PEN. RESISTANCE (Blows/ft)			WATER CONTENT (%)	SHEAR STRENGTH (TSF)*	UNCONFIN. COMP. (TSF)*
Dark brown, Sandy Lean Clay, moist, fine to coarse grained sand, low to moderate plasticity, trace rounded to sub-angular gravel, some roots, charcoal pieces, small rock fragments.	Firm to Stiff	CL		0							
						7	17	1.0			
Residual Soil: Light brown, Sandy Lean Clay, moist, fine to coarse grained sand, sub-angular to sub-rounded gravel, low plasticity, rock fragments, some roots, black oxide staining, rock fragments.	Stiff to Hard	CL									
				5		9	20	1.5			
						19	16	4.0			
						40	11				
Santa Clara Formation: Orange-brown, Sandstone, Siltstone, Shale, and Greenstone, very severely weathered, friable, some roots, black oxide staining, deformed fabric. Rock transitions to extremely weathered siltstone with gray mottling and some stratification. Note: The stratification lines represent the approximate boundary between soil and rock types, the actual transition may be gradual. *Measured using Torvane and Pocket Penetrometer devices.	Very Soft to Soft	BR									
				10		18	12				
						35	13				
						47	8				
				15		39	20				
						46	24				
Bottom of Boring at 18 feet.											
				20							

EXPLORATORY BORING LOG EB-3
 AWBREY 2-LOT DEVELOPMENT
 PORTOLA VALLEY, CALIFORNIA

BORING EB-3
 JUNE 2020
 PROJECT NO. 5082-1



DRILL TYPE: Minuteman with 3-1/4" Continuous Flight Auger

LOGGED BY: AS

DEPTH TO GROUND WATER: Not Encountered SURFACE ELEVATION: 903 feet

DATE DRILLED: 2/28/20

CLASSIFICATION AND DESCRIPTION	SOIL CONSISTENCY/ DENSITY or ROCK HARDNESS* (Figure A-2)	SOIL TYPE	SOIL SYMBOL	DEPTH (FEET)	SAMPLE INTERVAL	PEN. RESISTANCE (Blows/ft)		WATER CONTENT (%)	SHEAR STRENGTH (TSF)*	UNCONFIN. COMP. (TSF)*
Dark brown, Sandy Lean Clay, moist, fine to coarse grained sand, fine sub-angular to sub-rounded gravel, low plasticity, some rock fragments, some roots. ■ Liquid Limit = 24, Plasticity Index = 9.	Stiff to Very Stiff	CL		0						
						10	13	2.5		
						19	12	4.3		
Residual Soil: Brown, Sandy Lean Clay, moist, fine to coarse grained sand, fine sub-angular to rounded gravel, moderate plasticity, rock fragments, some roots.	Very Stiff	CL		5						
						25	16	3.5		
Santa Clara Formation: Orange-brown, Sandstone, Shale, and Siltstone, very severely weathered, friable, orange mottling, conglomeratic.	Very Soft to Soft	BR								
						62	18			
				10		35	16			
Bottom of Boring at 10.5 feet. Note: The stratification lines represent the approximate boundary between soil and rock types, the actual transition may be gradual. *Measured using Torvane and Pocket Penetrometer devices. Bottom of Boring at 20 feet.										
				15						
				20						

EXPLORATORY BORING LOG EB-4
AWBREY 2-LOT DEVELOPMENT
PORTOLA VALLEY, CALIFORNIA

BORING EB-4
JUNE 2020
PROJECT NO. 5082-1



APPENDIX B
LABORATORY TESTS

Samples from the subsurface exploration were selected for tests to help evaluate the physical and engineering properties of the soils. The tests performed are briefly described below.

The natural moisture content was determined in accordance with ASTM D2216 on most of the samples recovered from the borings. This test determines the moisture content, representative of field conditions, at the time the samples were collected. The results are presented on the boring logs at the appropriate sample depths.

The Atterberg Limits were determined on one sample in accordance with ASTM D 4318. The Atterberg limits are the moisture content within which the soil is workable or plastic. The results of this test are presented on Figure B-1 and on the logs of Boring EB-1 and EB-4 at the appropriate sample depths.



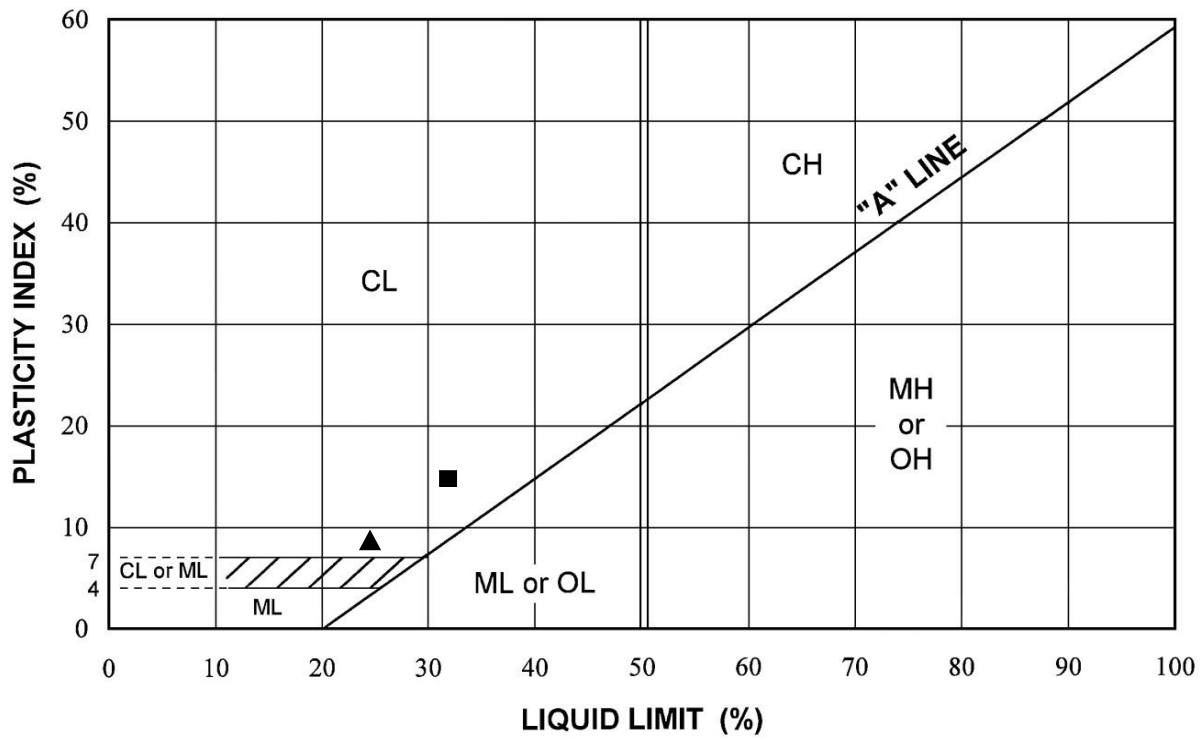

Chart Symbol	Boring Number	Sample Depth (feet)	Water Content (percent)	Liquid Limit (percent)	Plasticity Index (percent)	Liquidity Index (percent)	Passing No. 200 Sieve (percent)	USCS Soil Classification
■	EB-1	2-4	15	32	14	-21		CL
▲	EB-4	2-4	12	24	9	-33		CL

PLASTICITY CHART
 AWBREY 2-LOT DEVELOPMENT
 PORTOLA VALLEY, CALIFORNIA

FIGURE B-1
 JUNE 2020
 PROJECT NO. 5082-1





ROMIG ENGINEERS, INC.

1390 El Camino Real, 2nd Floor

San Carlos, California 94070

Phone: (650) 591-5224

www.romigengineers.com

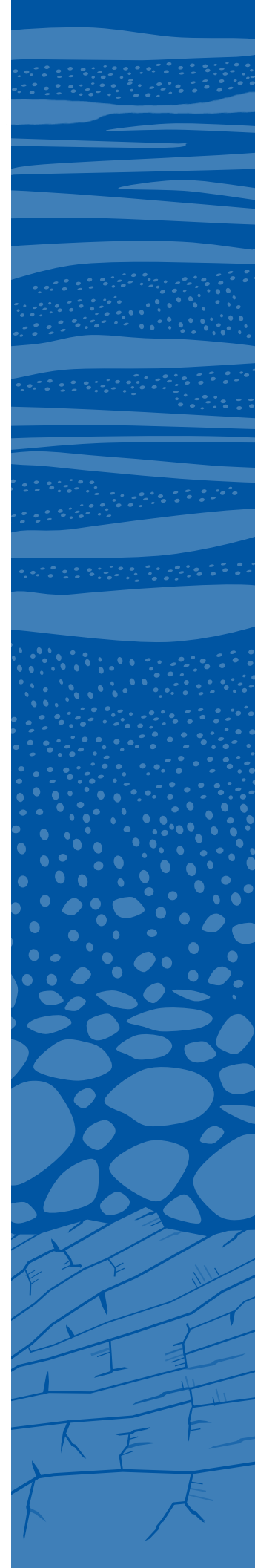



April 8, 2021
5082-1

Mr. Craig Awbrey
85 Saratoga Avenue, Suite 103
Santa Clara, California 95051

**RE: RESPONSE TO PEER REVIEW
AWBREY TWO-LOT DEVELOPEMENT
1061 LOS TRANCOS ROAD
PORTOLA VALLEY, CALIFORNIA
PLANNING NO: PLN2020-00356**

Dear Mr. Awbrey:

This letter was prepared to expand upon our June 25, 2020 report and respond to the geologic and geotechnical peer review comments provided in an email by Cotton, Shires and Associates (CSA), on March 3, 2020.

Review Comment #1

“The Engineering Geologic and Geotechnical Investigation report should include additional discussion of any existing landslide(s) extending under or potentially impacting the property. This discussion should be aided by including an original geologic map of the general site vicinity documenting the extent of the overall landslide complex, as well as identified individual landslide features within the complex, including individual landslide scarps and margins. In order to complete this geomorphic mapping, we anticipate that a detailed review and use of available processed LiDAR topographic information will be undertaken. In addition, engineering geologic cross sections should be prepared and included with the report on which are identified the inferred depth of landsliding, denoting the location of the property within the landslide complex. Cross sections of different scales may be appropriate to document shallower landslides within the complex identified during mapping of the site vicinity. Ground water conditions should be discussed and shown on the cross sections. Proposed grading and drainage improvements should also be included on the cross sections and evaluated. We note that ground water has been encountered at a depth of 38 feet along El Nido Road (CSA can provide this report) and at a depth of 14 feet along Bonita Road during recent geologic and geotechnical investigations (not yet submitted). We recommend consideration of supplemental, deeper borings to investigate potential geologic conditions at the site. The location of the San Andreas fault should be included on the map and cross section figures discussed above, where applicable.”

Response to Comment #1

Based on our site and vicinity reconnaissance and subsequent review of aerial photography and regional LIDAR, the site and surrounding area is underlain by a large-scale ancient landslide deposit, shown as a laterally extensive “probable” ancient landslide, as depicted by the Preliminary Map of Landslide Deposits in San Mateo County (Brabb and Pampeyan, 1972a) which is presented in Figure 5 of our 2020 report. This landslide complex underlies most of the Los Trancos Woods area as it extends from the crest of Coal Mine Ridge, southwest of the site, down to Los Trancos Creek, northeast of the site. We are not aware of any definitive determinations of the thickness of the landslide. Numerous/neighboring residences are located within/on this landslide, some constructed during the early 1900s and some constructed within the past 10 years.

The regional landslide appears to be a translational failure that transported large sections of the Santa Clara Formation bedrock downslope to the northeast. The subject site is located on the gently dipping northeast facing slope that is underlain by a likely intact block of the Santa Clara Formation within the middle portion of the mapped landslide, i.e. the site does not appear to be located on/near the landslide margin(s). Although there are no definitive determinations of the thickness of the landslide, the geometry of the landslide complex and its factions within the vicinity suggests that the landslide(s) may be on the order of 100 feet thick in the area of the subject site. Franciscan Complex rocks are inferred to underlie the site at greater depth. The generally subdued relief of the topography around the margin of the landslides in the vicinity indicates that they have not been remobilized within a recent or historic time frame. Our interpretation of the extent of the landslides within the vicinity of the subject property are shown on Supplemental Figure 1-LIDAR Geomorphology Map, and a regional cross section pertinent to the location of the site is shown on Supplemental Figure 2- Regional Cross Section A-A'.

The approximate locations of two traces of the San Andreas Fault are also indicated on Figures 1 and 2. The San Andreas Fault generally juxtaposes Santa Clara Formation strata on the southwest and Franciscan Complex greenstone and associated rocks to the northeast. The current active trace (identified as the Holocene trace on our figures) has been definitively identified at one location, 1227 Los Trancos Road, by trenching (Upp Geotechnology, Inc., 1996 and 1999). This fault trace is upslope and southwest of the site, and is characterized by fault line ridges and linear depressions as well as other typical active fault geomorphic features, although we note that some of the ground surface expressions are partially obscured by the large-scale landsliding and development. The older trace downslope and northeast of the site is approximately located on various geologic maps such as Brabb & Pampeyan (1972b), but to our knowledge has never been directly encountered/observed in the site vicinity. Neither of the fault traces pose a ground surface offset hazard to the subject site.

In addition, we expanded our local site cross sections to include the areas immediately downslope of the site(s) by utilizing San Mateo County GIS topography provided to us. Based on the extensions to our cross sections, shown on Supplemental Figures 3 and 4, grades appear to flatten downslope of the northern lot and appear to slope down relatively uniformly with a moderate grade beyond the south lot. We have also depicted the basement and at-grade areas to be supported on drilled pier foundations and have shown the proposed fill and lower retaining wall in the north corner of the northern lot.

In our experience, ground water in hillside environments underlain by bedrock at depth is both variable and largely dependent on local topography and the density/hardness of the subsurface materials at each site. This variability is further compounded in complex geologic environments near faulting and landsliding, such as the subject site and greater Los Trancos Woods. We note that we did not encounter water in the depth of our borings or trench, nor was ground water encountered during trenching of the adjacent lot at 1065 Los Trancos. In our opinion, the El Nido Road and Bonita Road locations noted in Comment #1 letter are distant and located in differing geomorphic settings from the subject site; therefore, ground water depths at these two sites do not appear to be directly applicable to the subject site.

Based on our expanded research and geomorphic mapping of the subject site and review of additional nearby project reports (provided by CSA/San Mateo County after our March 3, 2020 report), in our opinion, no additional hazards or concerns relating to landsliding were revealed. Rather, in developing the regional cross section, the site appears to be located a good distance from the margins of the large-scale landslide and situated on a likely intact block of the Santa Clara Formation, as shown in Supplemental Figures 1 and 2. In addition, we did not observe or identify any significant features of instability on the mild local slopes in the immediate areas of the subject site(s). As discussed in our 2020 report, our borings across the site encountered competent Santa Clara Formation bedrock which was confirmed and observed along the full length of the fault trench across the property. Based on the above information, in our opinion, we have determined that deeper borings are not warranted at the subject site, and further, we do not expect the associated development(s) on the site to be significantly impacted should remobilization of the large scale slide complex occur.

Review comment #2

“The report should include an opinion regarding the risk of identified landslides remobilizing during the anticipated design-life of the structure (~100 years). This opinion should include consideration of anticipated seismic shaking conditions during the design-life of the structure.”

Response to Comment #2:

Our discussions with other geologists active in the Los Trancos vicinity indicate a general concurrence that the identified regional landslides are not currently active, have not been active for several thousand years (geomorphic indications of active landsliding are not present), and that they are unlikely to reactivate under current climatic conditions. There may be a potential for reactivation of the slides during large earthquakes, such as occurrence of a 1906 level earthquake. However, as is shown on Figures 2 and 3, the site is not located within margins of potential landsliding (head or lateral scarp areas or landslide toe), and thus is not situated where relative ground movement or offset would occur. Seismic shaking would impact the site in the same manner as the surrounding area, and thus some post-shaking non-structural repairs may be required.

Review comment #3

“The report should include demonstration that the proposed improvements will not in any way adversely impact the stability of the overall landslide complex and local slopes in the vicinity of the site. Proposed areas of cut and fill and proposed drainage improvements, including drywells, should be considered in this assessment.”

Response to Comment #3

The proposed improvements consist of excavating and constructing a lower-level basement that will be constructed on the moderately sloping site and will daylight at the rear side. We understand from the civil project plans that the basement of the subject lot currently in planning submittal will require a cut of approximately 278 cubic yards and the second lot to be developed at a later time will require a cut of lesser height and volume. The height and volume of the cut(s) for the development is orders of magnitude smaller than the landslide complex’s overall mass and therefore we will focus this discussion on the local slope features.

We previously identified a possible small scale/shallow slump based on the change in topography at the north portion of the lot, which is discussed in our 2020 report and shown on Supplemental Figure 3. Based on the topography downslope and laterally as observed in our original site reconnaissance/mapping and as supported by the County GIS topographic data, in our opinion, this feature is expected to be very shallow (less than 4 feet thick). We note that this shallow feature and the materials encountered in Boring EB-3 were the impetus for supporting the structures on piers and providing downslope soil creep criteria within the upper 4 feet of the piers, which in our opinion, will provide adequate support for the structures proposed at the site. In addition, the owner plans to place a retaining wall at the property line supported on drilled piers and backfilled with engineered fill to flatten the grade, so overall slope will be flattened and stability increased.

We note that the upslope sides of the basement will be constructed as a cut into competent soils and bedrock that will be permanently supported by an engineered retaining wall that will account for the appropriate lateral earth pressures as well as appropriate seismic earth pressures based on a seismic event with a 475-year return period. As recommended in our report, the entire basement mat slab will be constructed on drilled piers which will provide sufficient lateral support of the basement and structure on/near the sloping grades.

As such, in our opinion, the development of the site which includes pier supported at-grade and basement structures is not expected to adversely impact the stability of the overall landslide complex, nor the local slopes in the vicinity of the site.

We agree that the planned rear drywell, which routes surface water into the ground of this hillside lot/environment should be revised to either route storm water discharge to the County storm drain system by pumping (if allowed by the County) or be routed to a portion of the site in a way that encourages surface flow of the water captured, such as a level spreader or a long surface/shallow dissipation trench which would more accurately mimic the natural course of water dissipating into the earth. We note that the basement subsurface drain system is not expected to capture large quantities of water and in our opinion could be routed responsibly to the rear yard by use of typical dissipation type systems at the lower portion of the site.

Review comment #4

The report should include adequate recommendations to assure that the proposed structures will not collapse in the event of remobilization of the identified landslides impacting the site, particularly during potential design-life seismic shaking events.”

Response to Comment #4:

In our opinion, the foundation recommendations provided in our June 25, 2020 remain adequate for the propose structure(s) to prevent collapse in the event of a design-level seismic shaking event and/or should the probable landslide complex remobilize in the Los Trancos Woods area.

Additional Discussion

We note that we have revised our cross sections to indicate that the Santa Clara Formation bedrock encountered across the site was likely displaced or translocated downslope over the course of the history of the probable landslide complex in the Los Trancos region so as not to imply that the Santa Clara Formation was in-situ or unmoved. This revision has been made on Figure 4.

We make no warranty, expressed or implied, for the services we perform for this project. Our services are performed in accordance with the geotechnical engineering principles generally accepted at this time and location.

Please call if you have questions or comments about site conditions or our responses presented in this letter.

Very truly yours,

ROMIG ENGINEERS, INC.



Alexander Shmurakov, G.I.T

Lucas J. Ottoboni, P.E.

David F. Hoexter, C.E.G

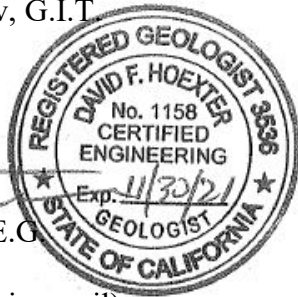

Copies: Addressee (via email)

LJO:DH:AS:pf

Attachments:

- Supplemental Figure 1: LIDAR Geomorphology Map
- Supplemental Figure 2: Regional Cross Section A-A'
- Supplemental Figure 3: Revised Site Plan Including Adjacent GIS Topographic Information
- Supplemental Figure 4: Extended Geologic Cross Sections A-A' and B-B'



References:

Brabb, Earl E. and Pampeyan, Earl H., 1972a, Preliminary Map of Landslide Deposits in San Mateo County, California, U.S. Geological Survey Map MF-344, Map Scale 1:62,500.

Brabb, Earl E, and Pampeyan, Earl H, 1972b, Preliminary Geologic Map of San Mateo County, California, USGS Miscellaneous Field Studies Map MF-328, Scale 1:62,500.

Romig Engineers, Inc, 2020, Geologic Evaluation and Geotechnical Investigation, 2-Lot Development, 1061 Los Trancos Road, Portola Valley, California, report dated June 25, 2020.

Upp Geotechnology, Inc., 1996, Fault Location and Geotechnical Investigation, Lands of Wickersham, 1227 Los Trancos Road, San Mateo County, California, report dated November 14, 1996.

Upp Geotechnology, Inc., 1999, Supplemental Report, Geotechnical Investigation, Lands of Wickersham, Parcel 2, APN 080-092-179, 1227 Los Trancos Road, San Mateo County, California, report dated September 24, 1999.

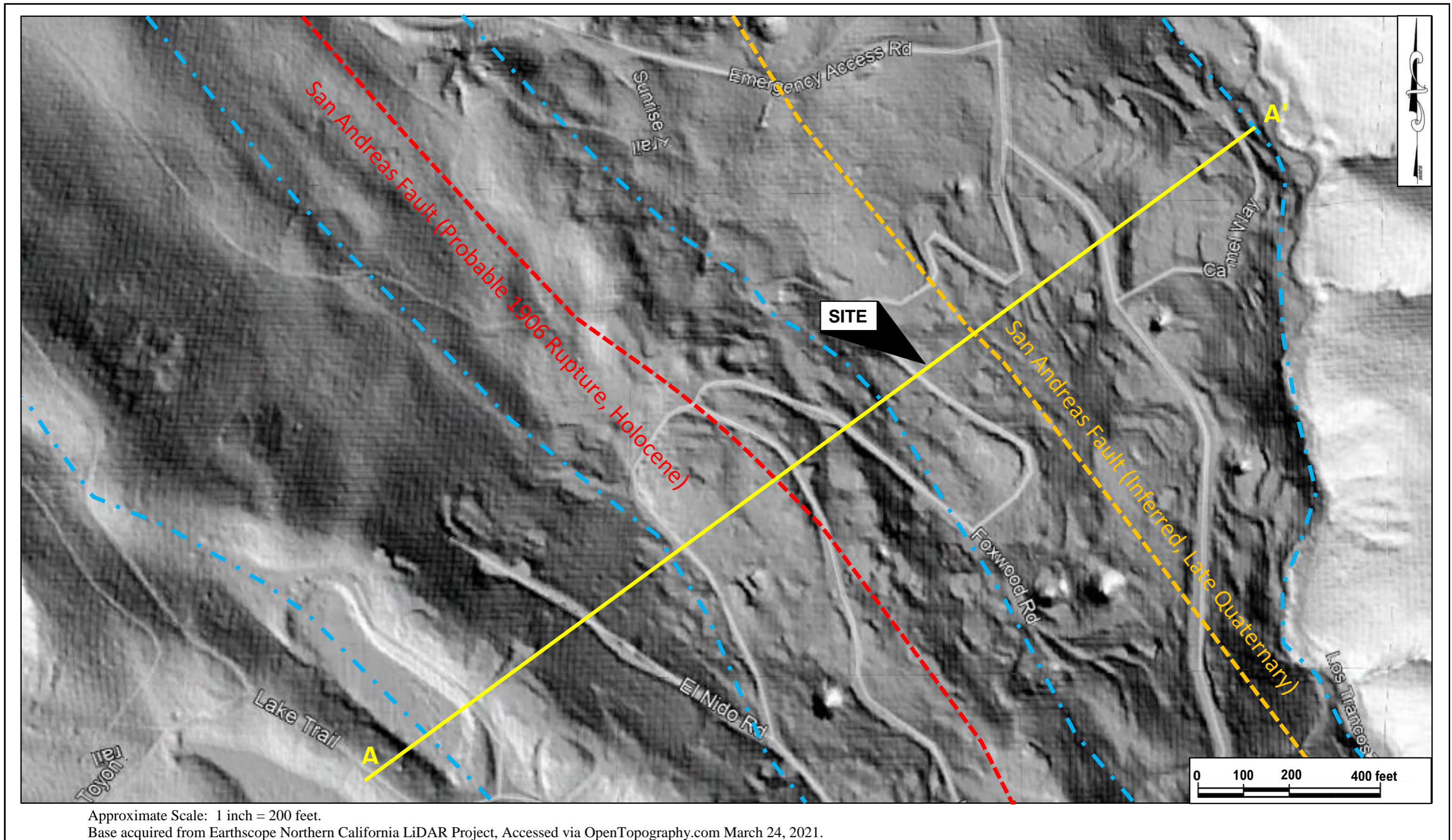

Regional Cross Section A-A'

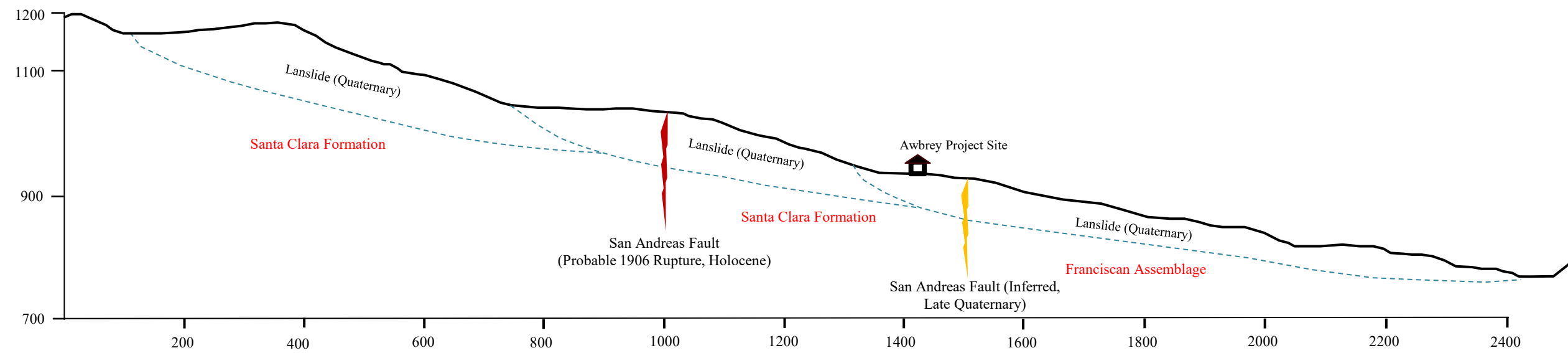

Approximate Scale in feet, as indicated, vertical = horizontal

LEGEND

- EB-4 Approximate Locations of Exploratory Borings
- Approximate Location of Fault Trench T-1 (Romig Engineers, 2020)
- Approximate Location of Fault Trench (Hoexter Consulting, 2003)
- Approximate Locations of Cross Sections (Figure 6)
- Qa** Artificial Fill
- Rs** Residual Soil derived from underlying Santa Clara Formation
- Limits of Possible Former Landslide
- Location of Planned Building Footprint
- Outline of Existing Structures

Note: No indication of settlement or lateral movement was observed in existing structures.

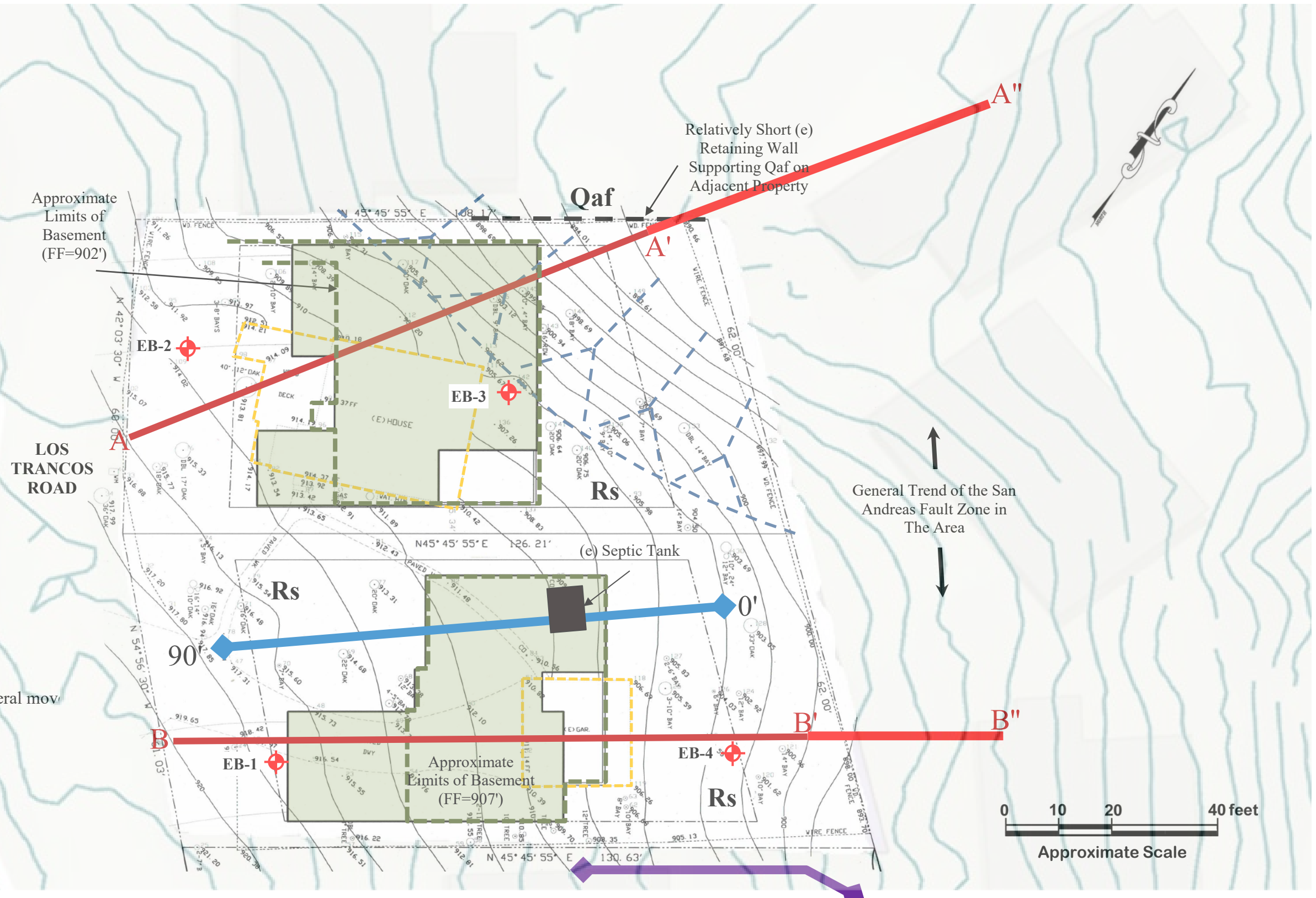

Approximate Scale: 1 inch = 20 feet.
 Base is site plan prepared by Westfall Engineers, Inc., August 2019.

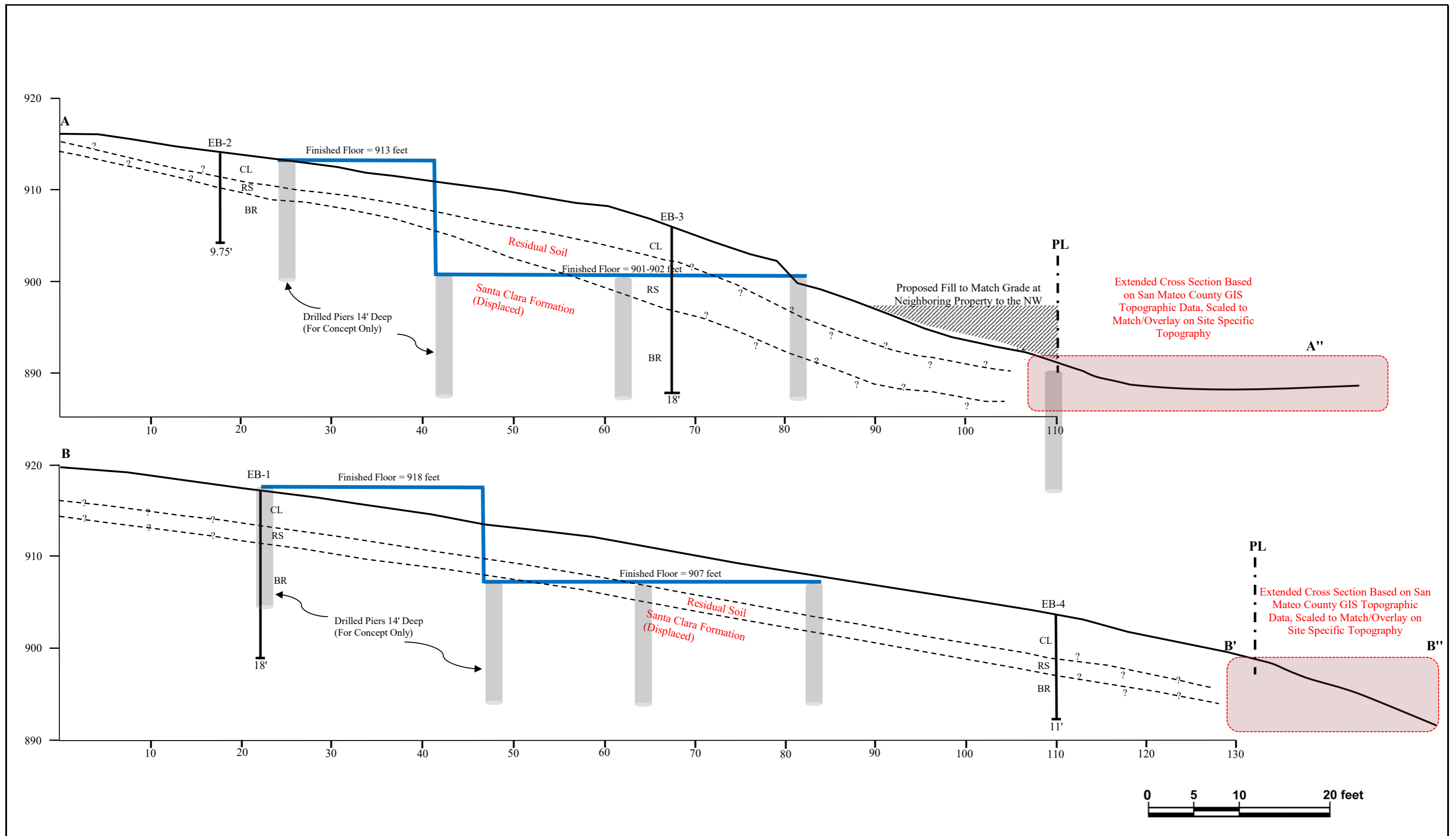

EXTENDED GEOLOGIC CROSS SECTIONS A-A' AND B-B'
 AWBREY RESIDENCES (RESPONSE TO CSA COMMENTS)
 PORTOLA VALLEY, CALIFORNIA





April 8, 2021
5082-1

Mr. Craig Awbrey
85 Saratoga Avenue, Suite 103
Santa Clara, California 95051

**RE: RESPONSE TO PEER REVIEW
AWBREY TWO-LOT DEVELOPEMENT
1061 LOS TRANCOS ROAD
PORTOLA VALLEY, CALIFORNIA
PLANNING NO: PLN2020-00356**

Dear Mr. Awbrey:

This letter was prepared to expand upon our June 25, 2020 report and respond to the geologic and geotechnical peer review comments provided in an email by Cotton, Shires and Associates (CSA), on March 3, 2020.

Review Comment #1

“The Engineering Geologic and Geotechnical Investigation report should include additional discussion of any existing landslide(s) extending under or potentially impacting the property. This discussion should be aided by including an original geologic map of the general site vicinity documenting the extent of the overall landslide complex, as well as identified individual landslide features within the complex, including individual landslide scarps and margins. In order to complete this geomorphic mapping, we anticipate that a detailed review and use of available processed LiDAR topographic information will be undertaken. In addition, engineering geologic cross sections should be prepared and included with the report on which are identified the inferred depth of landsliding, denoting the location of the property within the landslide complex. Cross sections of different scales may be appropriate to document shallower landslides within the complex identified during mapping of the site vicinity. Ground water conditions should be discussed and shown on the cross sections. Proposed grading and drainage improvements should also be included on the cross sections and evaluated. We note that ground water has been encountered at a depth of 38 feet along El Nido Road (CSA can provide this report) and at a depth of 14 feet along Bonita Road during recent geologic and geotechnical investigations (not yet submitted). We recommend consideration of supplemental, deeper borings to investigate potential geologic conditions at the site. The location of the San Andreas fault should be included on the map and cross section figures discussed above, where applicable.”

Response to Comment #1

Based on our site and vicinity reconnaissance and subsequent review of aerial photography and regional LIDAR, the site and surrounding area is underlain by a large-scale ancient landslide deposit, shown as a laterally extensive “probable” ancient landslide, as depicted by the Preliminary Map of Landslide Deposits in San Mateo County (Brabb and Pampeyan, 1972a) which is presented in Figure 5 of our 2020 report. This landslide complex underlies most of the Los Trancos Woods area as it extends from the crest of Coal Mine Ridge, southwest of the site, down to Los Trancos Creek, northeast of the site. We are not aware of any definitive determinations of the thickness of the landslide. Numerous/neighboring residences are located within/on this landslide, some constructed during the early 1900s and some constructed within the past 10 years.

The regional landslide appears to be a translational failure that transported large sections of the Santa Clara Formation bedrock downslope to the northeast. The subject site is located on the gently dipping northeast facing slope that is underlain by a likely intact block of the Santa Clara Formation within the middle portion of the mapped landslide, i.e. the site does not appear to be located on/near the landslide margin(s). Although there are no definitive determinations of the thickness of the landslide, the geometry of the landslide complex and its factions within the vicinity suggests that the landslide(s) may be on the order of 100 feet thick in the area of the subject site. Franciscan Complex rocks are inferred to underlie the site at greater depth. The generally subdued relief of the topography around the margin of the landslides in the vicinity indicates that they have not been remobilized within a recent or historic time frame. Our interpretation of the extent of the landslides within the vicinity of the subject property are shown on Supplemental Figure 1-LIDAR Geomorphology Map, and a regional cross section pertinent to the location of the site is shown on Supplemental Figure 2- Regional Cross Section A-A'.

The approximate locations of two traces of the San Andreas Fault are also indicated on Figures 1 and 2. The San Andreas Fault generally juxtaposes Santa Clara Formation strata on the southwest and Franciscan Complex greenstone and associated rocks to the northeast. The current active trace (identified as the Holocene trace on our figures) has been definitively identified at one location, 1227 Los Trancos Road, by trenching (Upp Geotechnology, Inc., 1996 and 1999). This fault trace is upslope and southwest of the site, and is characterized by fault line ridges and linear depressions as well as other typical active fault geomorphic features, although we note that some of the ground surface expressions are partially obscured by the large-scale landsliding and development. The older trace downslope and northeast of the site is approximately located on various geologic maps such as Brabb & Pampeyan (1972b), but to our knowledge has never been directly encountered/observed in the site vicinity. Neither of the fault traces pose a ground surface offset hazard to the subject site.

In addition, we expanded our local site cross sections to include the areas immediately downslope of the site(s) by utilizing San Mateo County GIS topography provided to us. Based on the extensions to our cross sections, shown on Supplemental Figures 3 and 4, grades appear to flatten downslope of the northern lot and appear to slope down relatively uniformly with a moderate grade beyond the south lot. We have also depicted the basement and at-grade areas to be supported on drilled pier foundations and have shown the proposed fill and lower retaining wall in the north corner of the northern lot.

In our experience, ground water in hillside environments underlain by bedrock at depth is both variable and largely dependent on local topography and the density/hardness of the subsurface materials at each site. This variability is further compounded in complex geologic environments near faulting and landsliding, such as the subject site and greater Los Trancos Woods. We note that we did not encounter water in the depth of our borings or trench, nor was ground water encountered during trenching of the adjacent lot at 1065 Los Trancos. In our opinion, the El Nido Road and Bonita Road locations noted in Comment #1 letter are distant and located in differing geomorphic settings from the subject site; therefore, ground water depths at these two sites do not appear to be directly applicable to the subject site.

Based on our expanded research and geomorphic mapping of the subject site and review of additional nearby project reports (provided by CSA/San Mateo County after our March 3, 2020 report), in our opinion, no additional hazards or concerns relating to landsliding were revealed. Rather, in developing the regional cross section, the site appears to be located a good distance from the margins of the large-scale landslide and situated on a likely intact block of the Santa Clara Formation, as shown in Supplemental Figures 1 and 2. In addition, we did not observe or identify any significant features of instability on the mild local slopes in the immediate areas of the subject site(s). As discussed in our 2020 report, our borings across the site encountered competent Santa Clara Formation bedrock which was confirmed and observed along the full length of the fault trench across the property. Based on the above information, in our opinion, we have determined that deeper borings are not warranted at the subject site, and further, we do not expect the associated development(s) on the site to be significantly impacted should remobilization of the large scale slide complex occur.

Review comment #2

“The report should include an opinion regarding the risk of identified landslides remobilizing during the anticipated design-life of the structure (~100 years). This opinion should include consideration of anticipated seismic shaking conditions during the design-life of the structure.”

Response to Comment #2:

Our discussions with other geologists active in the Los Trancos vicinity indicate a general concurrence that the identified regional landslides are not currently active, have not been active for several thousand years (geomorphic indications of active landsliding are not present), and that they are unlikely to reactivate under current climatic conditions. There may be a potential for reactivation of the slides during large earthquakes, such as occurrence of a 1906 level earthquake. However, as is shown on Figures 2 and 3, the site is not located within margins of potential landsliding (head or lateral scarp areas or landslide toe), and thus is not situated where relative ground movement or offset would occur. Seismic shaking would impact the site in the same manner as the surrounding area, and thus some post-shaking non-structural repairs may be required.

Review comment #3

“The report should include demonstration that the proposed improvements will not in any way adversely impact the stability of the overall landslide complex and local slopes in the vicinity of the site. Proposed areas of cut and fill and proposed drainage improvements, including drywells, should be considered in this assessment.”

Response to Comment #3

The proposed improvements consist of excavating and constructing a lower-level basement that will be constructed on the moderately sloping site and will daylight at the rear side. We understand from the civil project plans that the basement of the subject lot currently in planning submittal will require a cut of approximately 278 cubic yards and the second lot to be developed at a later time will require a cut of lesser height and volume. The height and volume of the cut(s) for the development is orders of magnitude smaller than the landslide complex’s overall mass and therefore we will focus this discussion on the local slope features.

We previously identified a possible small scale/shallow slump based on the change in topography at the north portion of the lot, which is discussed in our 2020 report and shown on Supplemental Figure 3. Based on the topography downslope and laterally as observed in our original site reconnaissance/mapping and as supported by the County GIS topographic data, in our opinion, this feature is expected to be very shallow (less than 4 feet thick). We note that this shallow feature and the materials encountered in Boring EB-3 were the impetus for supporting the structures on piers and providing downslope soil creep criteria within the upper 4 feet of the piers, which in our opinion, will provide adequate support for the structures proposed at the site. In addition, the owner plans to place a retaining wall at the property line supported on drilled piers and backfilled with engineered fill to flatten the grade, so overall slope will be flattened and stability increased.

We note that the upslope sides of the basement will be constructed as a cut into competent soils and bedrock that will be permanently supported by an engineered retaining wall that will account for the appropriate lateral earth pressures as well as appropriate seismic earth pressures based on a seismic event with a 475-year return period. As recommended in our report, the entire basement mat slab will be constructed on drilled piers which will provide sufficient lateral support of the basement and structure on/near the sloping grades.

As such, in our opinion, the development of the site which includes pier supported at-grade and basement structures is not expected to adversely impact the stability of the overall landslide complex, nor the local slopes in the vicinity of the site.

We agree that the planned rear drywell, which routes surface water into the ground of this hillside lot/environment should be revised to either route storm water discharge to the County storm drain system by pumping (if allowed by the County) or be routed to a portion of the site in a way that encourages surface flow of the water captured, such as a level spreader or a long surface/shallow dissipation trench which would more accurately mimic the natural course of water dissipating into the earth. We note that the basement subsurface drain system is not expected to capture large quantities of water and in our opinion could be routed responsibly to the rear yard by use of typical dissipation type systems at the lower portion of the site.

Review comment #4

The report should include adequate recommendations to assure that the proposed structures will not collapse in the event of remobilization of the identified landslides impacting the site, particularly during potential design-life seismic shaking events.”

Response to Comment #4:

In our opinion, the foundation recommendations provided in our June 25, 2020 remain adequate for the propose structure(s) to prevent collapse in the event of a design-level seismic shaking event and/or should the probable landslide complex remobilize in the Los Trancos Woods area.

Additional Discussion

We note that we have revised our cross sections to indicate that the Santa Clara Formation bedrock encountered across the site was likely displaced or translocated downslope over the course of the history of the probable landslide complex in the Los Trancos region so as not to imply that the Santa Clara Formation was in-situ or unmoved. This revision has been made on Figure 4.

We make no warranty, expressed or implied, for the services we perform for this project. Our services are performed in accordance with the geotechnical engineering principles generally accepted at this time and location.

Please call if you have questions or comments about site conditions or our responses presented in this letter.

Very truly yours,

ROMIG ENGINEERS, INC.

Alexander Shmurakov, G.I.T

Lucas J. Ottoboni, P.E.

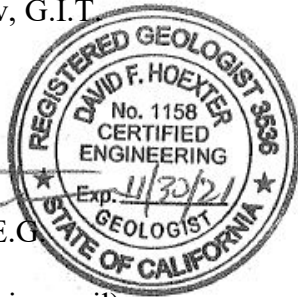

David F. Hoexter, C.E.G

Copies: Addressee (via email)

LJO:DH:AS:pf

Attachments:

- Supplemental Figure 1: LIDAR Geomorphology Map
- Supplemental Figure 2: Regional Cross Section A-A'
- Supplemental Figure 3: Revised Site Plan Including Adjacent GIS Topographic Information
- Supplemental Figure 4: Extended Geologic Cross Sections A-A' and B-B'

References:

Brabb, Earl E. and Pampeyan, Earl H., 1972a, Preliminary Map of Landslide Deposits in San Mateo County, California, U.S. Geological Survey Map MF-344, Map Scale 1:62,500.

Brabb, Earl E, and Pampeyan, Earl H, 1972b, Preliminary Geologic Map of San Mateo County, California, USGS Miscellaneous Field Studies Map MF-328, Scale 1:62,500.

Romig Engineers, Inc, 2020, Geologic Evaluation and Geotechnical Investigation, 2-Lot Development, 1061 Los Trancos Road, Portola Valley, California, report dated June 25, 2020.

Upp Geotechnology, Inc., 1996, Fault Location and Geotechnical Investigation, Lands of Wickersham, 1227 Los Trancos Road, San Mateo County, California, report dated November 14, 1996.

Upp Geotechnology, Inc., 1999, Supplemental Report, Geotechnical Investigation, Lands of Wickersham, Parcel 2, APN 080-092-179, 1227 Los Trancos Road, San Mateo County, California, report dated September 24, 1999.

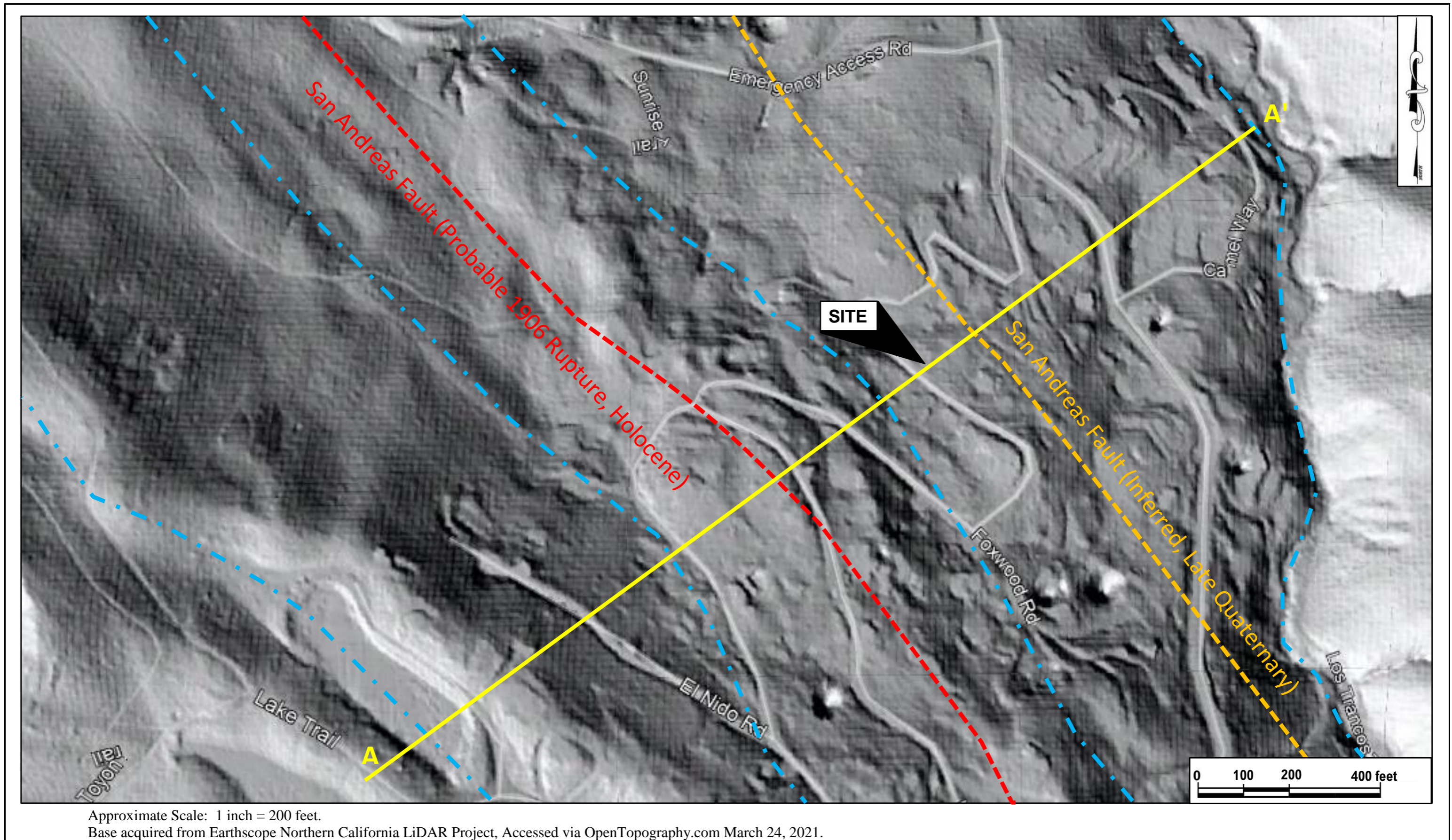

Regional Cross Section A-A'

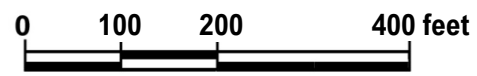
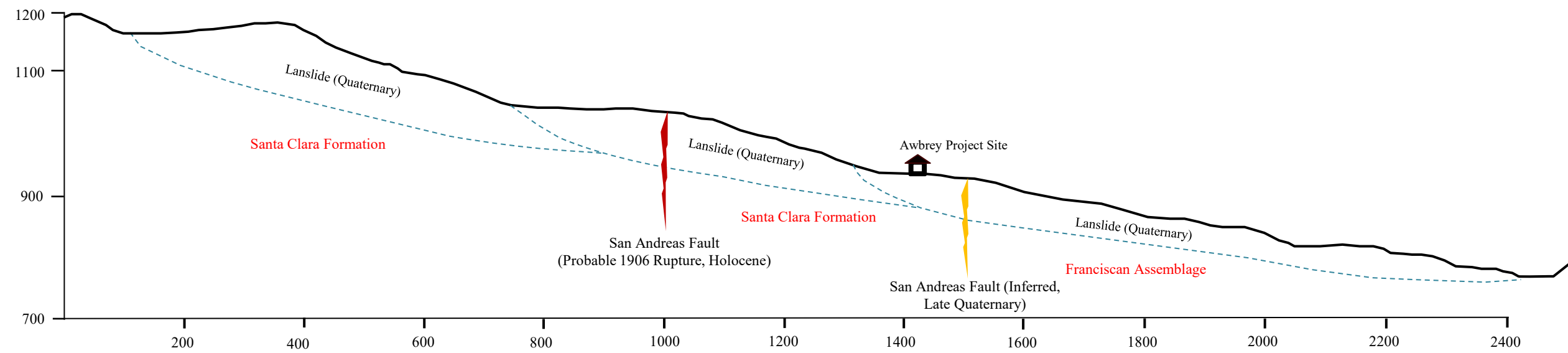

Approximate Scale in feet, as indicated, vertical = horizontal

LEGEND

- EB-4 Approximate Locations of Exploratory Borings
- Approximate Location of Fault Trench T-1 (Romig Engineers, 2020)
- Approximate Location of Fault Trench (Hoexter Consulting, 2003)
- Approximate Locations of Cross Sections (Figure 6)
- Qa** Artificial Fill
- Rs** Residual Soil derived from underlying Santa Clara Formation
- Limits of Possible Former Landslide
- Location of Planned Building Footprint
- Outline of Existing Structures

Note: No indication of settlement or lateral movement was observed in existing structures.

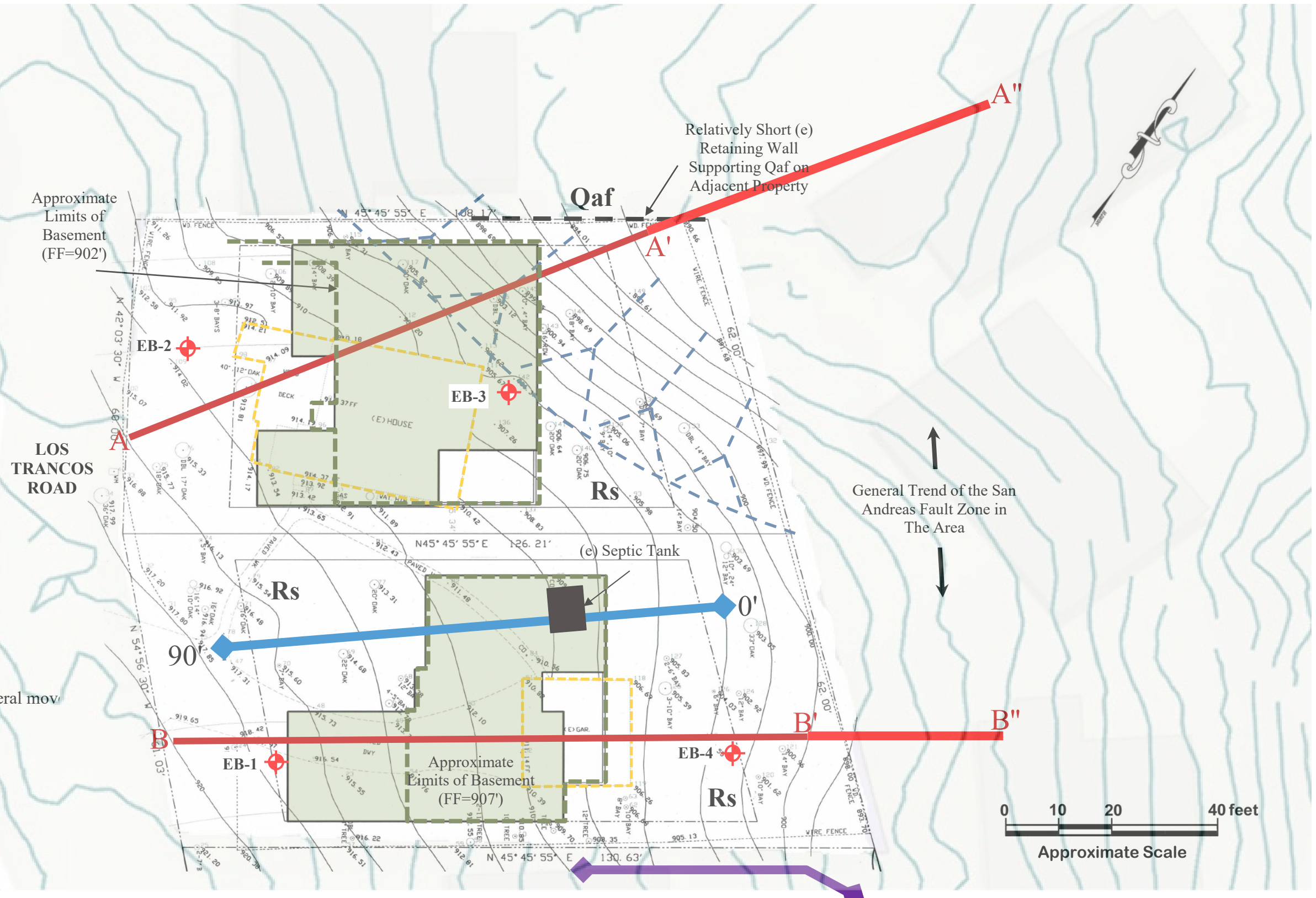

Approximate Scale: 1 inch = 20 feet.
 Base is site plan prepared by Westfall Engineers, Inc., August 2019.

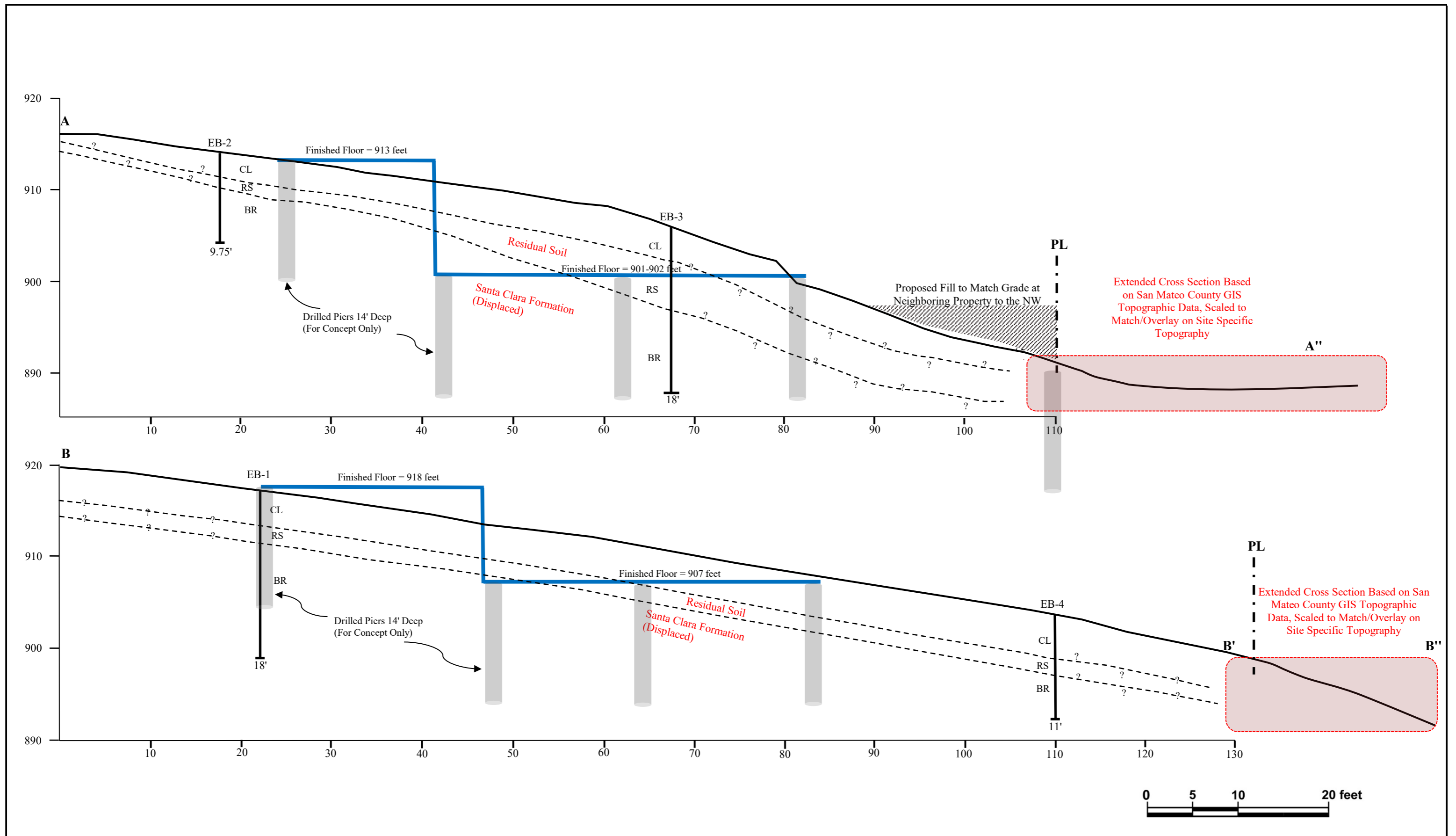

EXTENDED GEOLOGIC CROSS SECTIONS A-A' AND B-B'
 AWBREY RESIDENCES (RESPONSE TO CSA COMMENTS)
 PORTOLA VALLEY, CALIFORNIA





County of San Mateo - Planning and Building Department

ATTACHMENT F

June 18, 2021

Awbrey Development
85 Saratoga Avenue #103
Santa Clara, CA 95051

Dear Mr. Awbrey:

SUBJECT: Grading Permit for New Single-Family Dwelling
1061 Los Trancos Road, Portola Valley
APN: 080-084-320; County File No. PLN 2020-00356

Staff has completed its review of your application for a staff-level Grading Permit to allow 278 cubic yards of cut and 178 cubic yards of fill in association with the demolition of an existing single family residence and the construction of a new 3,985.7 sq. ft. two-story single-family residence with an attached 446 sq. ft. garage and attached 779.9 sq. ft. accessory dwelling unit located on a legal 7,026 sq. ft. parcel. The project involves the removal of seven (7) significant trees in the footprint of the proposed home, which includes three valley oak trees (16.3" - 20" DBH), one redwood tree (16" DBH), and three bay trees (14" - 18" DBH).

The grading permit application submitted on October 20th, 2020, including the Grading Plan and the Geotechnical Report dated June 25, 2020 with a subsequent Geotechnical revision dated April 8, 2021, has been reviewed and conditionally approved by the Department of Public Works, Building Inspection Section, Geotechnical Section, Drainage Section, County Fire, and sewer and water service providers. Public notification for this project was sent out to property owners with 300 feet of the subject property on May 26, 2021. The public comment period began on May 27, 2021 and ended on June 9, 2021. Three (3) comments were received requesting additional information from staff and objecting to the proposed project. The comments received cited concerns with the number of trees proposed for removal and recommended extensive tree replacement. Additionally, a neighbor was concerned about the current geotechnical hazards present on site and the possible exacerbating of these hazards that new construction would create for neighboring parcels. The applicant is retaining trees that are outside of the footprint of the new home. Due to the size of the mature trees to be preserved on site there is little room to safely plant additional native trees. However, staff has added a condition requiring the planting of one additional tree on site. The geotechnical report submitted by the applicant has been peer reviewed and conditionally approved by the County's Geotechnical Section. The final geotechnical report and engineering recommendations from the document will be reviewed during the building permit phase to ensure all building health and safety requirements are met.

Based on the foregoing, staff has **approved** your permit subject to the following required findings and conditions of approval.



FINDINGS

Staff found that:

For the Environmental Review

1. The project is exempt from environmental review pursuant to the California Environmental Quality Act (CEQA), Section 15303, Class 3, related to the construction of a single-family residence in a residential zone.

For the Tree Removal

2. The required action is necessary to allow reasonable economic enjoyment of the property.
3. The trees will be replaced by plantings approved by the Community Development Director, or designee.

For the Grading Permit

4. The granting of this permit will have no significant adverse effect on the environment. This project has been reviewed and approved by the Department of Public Works and the Building Inspection Geotechnical and Drainage Sections. With implementation of the proposed Grading Plan and Condition of Approval No. 12, which requires the project engineer provide written certification that all grading has been completed in conformance with the approved plans, Grading Regulations, and conditions of approval, the potential for impacts related to geologic conditions is minimized to a less than significant level. Similarly, implementation of the approved Erosion Control Plan and Tree Protection Plan will protect on site and neighboring trees and minimize the potential for significant erosion on site.
5. The project conforms to the criteria of Chapter 5, Division VII, San Mateo County Ordinance Code, including the standards referenced in Section 9296. Planning staff, the Geotechnical Section, Department of Public Works, and the Building Department's Drainage Section have reviewed the project and have determined the project as proposed and conditioned conforms to the criteria of Chapter 8, Division VII, San Mateo County Ordinance Code, including timing of grading activity, implementation of erosion and sediment control measures, and dust control measures.
6. The project is consistent with the General Plan. The subject site has a General Plan land use designation of Low Density Residential. The proposed project is consistent with the allowed density and land use designation. As proposed and

conditioned, the project complies with General Plan Policy 2.17 (*Regulate Development to Minimize Soil Erosion and Sedimentation*) and Policy 2.23 (*Regulate Excavation, Grading, Filling, and Land Clearing Activities Against Accelerated Soil Erosion*) as the project includes measures and conditions to control and address each of these items.

CONDITIONS OF APPROVAL

Current Planning Section

1. This approval applies only to the proposal as described in the latest plans, supporting materials, and reports submitted as of the date of this letter. Minor revisions or modifications to the project may be made subject to the review and approval of the Community Development Director, if they are consistent with the intent of, and in substantial conformance with, this approval.
2. The grading permit shall be valid for one (1) year from the date of final approval, in which time a building permit shall be issued and a completed inspection (to the satisfaction of the Building Inspection Section) shall have occurred within 365 days of its issuance. The Grading Permit (issued as the "hard card" with all necessary information filed out and signatures obtained) shall only be issued concurrently with the building permit for the new single-family residence. No grading activities shall commence until all permits have been issued. Approval of permits may be extended by a 1-year increment upon written request and payment of applicable extension fees 60 days prior to expiration.
3. No grading shall be allowed during the winter season (October 1 to April 30) or during any rain event to avoid potential soil erosion unless approved, in writing, by the Community Development Director. The applicant shall submit an Exception to the Winter Grading Moratorium application along with a winterization plan to the Current Planning Section, at least, two weeks prior to the projected commencement of grading activities stating the date when grading will begin for consideration for an exemption to the Winter Grading Moratorium.
4. This permit allows for the removal of seven (7) significant trees as shown on the approved plans. Removal of any additional trees with a diameter greater than 12 inches (as measured 4.5 feet above the ground) shall require a separate tree removal permit application and payment of applicable fees.
5. One oak tree using a minimum 15-gallon stock shall be planted for the trees removed. All proposed replacement trees shall be shown on a Tree Replanting Plan or Landscape Plan and shall include species, size and location. The Plan shall be submitted to the County Planning and Building Department for review and approval as part of the building permit plan sets.

6. An arborist report shall be submitted prior to final inspection documenting the health of the existing trees post construction. If any of the trees have been damaged by construction such that they are considered “effectively removed” pursuant to Section 12,091.1 of the Significant Tree Ordinance, an after-the-fact tree removal application and payment of applicable fees shall be required and processed prior to final building inspection.
7. The provision of the San Mateo County Grading Ordinance shall govern all grading on and adjacent to this site. Per San Mateo County Ordinance Section 9296.5, all equipment used in grading operations shall meet spark arrester and firefighting tool requirements, as specified in the California Public Resources Code.
8. The engineer who prepared the approved grading plan shall be responsible for the inspection and certification of the grading as required by Section 9297.2 of the Grading Ordinance. The engineer’s responsibilities shall include those relating to non-compliance detailed in Section 9297.4 of the Grading Ordinance.
9. Prior to the beginning of all construction, the applicant shall implement the approved erosion and sediment control plan and tree protection plan, which shall be maintained throughout the duration of the project. The goal is to prevent significant trees, as defined by San Mateo County’s Significant Tree Ordinance, Section 12,000, from injury or damage related to construction activities, prevent sediment and other pollutants from leaving the project site and to protect all exposed earth surfaces from erosive forces. Said plan shall adhere to the San Mateo County Wide Stormwater Pollution Prevention Program “General Construction and Site Supervision Guidelines,” including:
 - a. Stabilizing all denuded areas and maintaining erosion control measures continuously between October 1 and April 30. Stabilizing shall include both proactive measures, such as the placement of hay bales or coir netting, and the use passive measures, such as revegetating disturbed areas with plants propagated from seed collected in the immediate area.
 - b. Storing, handling, and disposing of construction materials and wastes properly, so as to prevent their contact with stormwater.
 - c. Controlling and preventing the discharge of all potential pollutants, including pavement cutting wastes, paints, concrete, petroleum products, chemicals, wash water or sediments, and non-stormwater discharges to storm drains and watercourses.
 - d. Using sediment controls or filtration to remove sediment when dewatering site and obtain all necessary permits.
 - e. Avoiding cleaning, fueling, or maintaining vehicles on-site, except in a designated area where wash water is contained and treated.

- f. Delineating with field markers clearing limits, easements, setbacks, sensitive or critical areas, buffer zones, trees, and drainage courses.
 - g. Protecting adjacent properties and undisturbed areas from construction impacts using vegetative buffer strips, sediment barriers or filters, dikes, mulching, or other measures as appropriate.
 - h. Performing clearing and earth moving activities only during dry weather.
 - i. Limiting and timing application of pesticides and fertilizers to prevent polluted runoff.
 - j. Limiting construction access routes and stabilize designated access points.
 - k. Avoiding tracking dirt or other materials off-site; clean off-site paved areas and sidewalks using dry sweeping methods.
 - l. The contractor shall train and provide instruction to all employees and subcontractors regarding the construction Best Management Practices.
 - m. The approved erosion and sediment control plan shall be implemented prior to the beginning of construction.
 - n. Failure to install or maintain these measures will result in stoppage of construction until the corrections have been made and fees paid for staff enforcement time.
10. All grading and erosion and sediment control measures shall be in accordance to the plans prepared by Vit Hanacek Engineering, dated October 14, 2020, and approved by the Department of Public Works, Geotechnical Section, and the Current Planning Section. Revisions to the approved grading plan shall be prepared and signed by the engineer and shall be submitted to the Building Inspection Section and the Current Planning Section concurrently prior to commencing any work pursuant to the proposed revision.
11. It shall be the responsibility of the applicant's engineer to regularly inspect the erosion control measures and determine that they are functioning as designed and that proper maintenance is being performed. Deficiencies shall be immediately corrected.
12. For the final approval of the Grading Permit, the applicant shall ensure the performance of the following activities within thirty (30) days of the completion of grading:
- a. The engineer shall submit written certification to the Department of Public Works and the Geotechnical Section that all grading has been completed in conformance with the approved plans, conditions of approval, and the Grading Ordinance.

- b. All applicable work during construction shall be subject to observation and approval by the geotechnical consultant. Section II of the Geotechnical Consultant Approval form must be submitted to the County's Geotechnical Engineer and Current Planning Section.
13. Noise sources associated with demolition, construction, repair, remodeling, or grading of any real property shall be limited to the hours from 7:00 a.m. to 6:00 p.m. weekdays and 9:00 a.m. to 5:00 p.m. Saturdays. Said activities are prohibited on Sundays, Thanksgiving and Christmas (San Mateo Ordinance Code Section 4.88.360).
14. An Erosion Control and/or Tree Protection Pre-site Inspection is required prior to the issuance of a building permit for construction and demolition to ensure the approved erosion control and tree protection measures are installed adequately prior to the start of ground disturbing activities. Once all review agencies have approved your building permit, you will be issued an approved job copy of the Erosion Control and/or Tree Protection Plan. Once the Erosion Control and/or Tree Protection measures have been installed per the approved plans, please contact the project planner of record to schedule a pre-site inspection. A \$144 inspection fee will be assessed to the building permit for the inspection. If the initial pre-site inspection is not approved, an additional inspection fee will be assessed for each required re-inspection until the job site passes the Pre-Site Inspection.
15. To reduce the impact of construction activities on neighboring properties, comply with the following:
 - a. All debris shall be contained on-site; a dumpster or trash bin shall be provided on site during construction to prevent debris from blowing onto adjacent properties. The applicant shall monitor the site to ensure that trash is picked up and appropriately disposed of daily.
 - b. The applicant shall remove all construction equipment from the site upon completion of the use and/or need of each piece of equipment which shall include but not be limited to tractors, back hoes, cement mixers, etc.
 - c. The applicant shall ensure that no construction-related vehicles shall impede through traffic along the right-of-way on Los Trancos Road. All construction vehicles shall be parked on-site outside the public right-of-way or in locations which do not impede safe access on Los Trancos Road. There shall be no storage of construction vehicles in the public right-of-way.
16. The site is considered a Construction Stormwater Regulated Site (SWRS). Any grading activities conducted during the wet weather season (October 1 to April 30) will require monthly erosion and sediment control inspections by the Building Inspection Section, as

well as prior authorization from the Community Development Director to conduct grading during the wet weather season.

Building Inspection Section

17. A building permit is required.

Geotechnical Section

18. The Project Geotechnical Consultant should utilize the current LiDAR information to further examine and consider the prominent land sliding features, and incorporate into the grading and foundation designs, and land stabilization if any, during the Building Permit application stage.
19. A Geotechnical Report shall be submitted at the Building Permit stage, the report shall be updated to the current adopted code (if 2021 -> CBC2019). Significant grading profiles, grading proposals, foundation design recommendations, retaining wall design recommendations, and basement design recommendations, if any, shall be provided in the geotechnical report at Building Stage. For a vacant site, the Geotechnical Report shall provide sufficient soil investigation data to evaluate the potential hazards, for example, expansive soils, soil corrosivity, weak soil strength, and liquefaction. If any hazards are found, mitigation shall be provided in foundation design and grading proposal.

Drainage Section

20. At the time of building permit submittal, the following shall be required:
 - a. Final Drainage Report stamped and signed by a registered Civil Engineer.
 - b. Final Grading and Drainage Plan stamped and signed by a registered Civil Engineer.
 - c. Final C.3 and C.6 Checklist.

Department of Public Works

21. The project shall comply with the San Mateo County Drainage Policy and the San Mateo Countywide National Pollution Discharge Elimination System (NPDES) permit. Prior to the issuance of the Building permit, the applicant shall submit a plan with construction details conforming with County standards, and a drainage analysis including narrative and calculations showing pre-development and post-development runoff onto and off of the parcel demonstrating compliance with the

Policy for review and approval by the Department of Public Works.

22. Prior to the issuance of the Building Permit, the applicant shall submit a driveway "Plan and Profile," to the Department of Public Works, showing the driveway access to the parcel (garage slab) complying with County standards for driveway slopes (not to exceed 20%) and to County standards for driveways (at the property line) being the same elevation as the center of the access roadway. When appropriate, as determined by the Department of Public Works, this plan and profile shall be prepared from elevations and alignment shown on the roadway improvement plans. The driveway plan shall also include and show specific provisions and details for both the existing and the proposed drainage patterns and drainage facilities.
23. No proposed construction work within the County right-of-way shall begin until County requirements for the issuance of an encroachment permit, including review of the plans, have been met and an encroachment permit issued. The applicant shall contact a Department of Public Works Inspector 48 hours prior to commencing work in the right-of-way.
24. Prior to the issuance of the Building Permit, the applicant will be required to provide payment of "roadway mitigation fees" based on the square footage (assessable space) of the proposed building per Ordinance #3277.

Woodside Fire Protection District

25. At the start of construction, a 2' x 3' address sign shall be posted in front of project site.
26. At the time of final inspection, the permanent address shall be mounted and clearly visible from the street with a minimum of 4" numbers on contrasting background.
27. One hundred (100) feet of defensible space shall be provided for the structure prior to the start of construction.
28. Upon final inspection thirty (30) feet perimeter property line defensible space shall be provided per Woodside Fire Protection District (WFPD) ordinance section 304.1.2.A
29. Approved spark arrestors will be required on all installed chimneys including outside fireplaces.
30. The applicant shall install Smoke and Carbon Dioxide detectors per 2019 CBC.
31. NFPA 13D Fire Sprinkler System shall be installed. Sprinkler plans/calculations shall be submitted separately to WFPD. The Owner/Contractor is responsible for getting the correct water flow data and that Cal-Water requires a backflow device that can decrease the water flow pressure by 12-15 PSI due to friction loss of the backflow device.

32. The driveway as proposed meets WFPD standards. If driveway dimensions are revised during construction, it must maintain compliance with WFPD standards.
33. The minimum fire flow shall be 1,000 GPM. A water supply for fire protection shall mean a fire hydrant within 600' from the building, capable of the required flow. Distance from the hydrant to the structure shall be measured via an approved roadway in which the engine can safely drive from the fire hydrant to the front door of the structure.
34. There is a fire hydrant within 600' of the property, a fire water flow test will need to be completed. Provide water flow information from Cal Water during the building permit phase.

West Bay Sanitary District (WBSD)

35. To complete annexation, the applicant shall submit a WBSD annexation application to the District office.
36. A Class 1 Permit fee is required. Connection & Reimbursement fees will be due for the Single Family Residence and Accessory Dwelling Unit.

California Water Service – Bear Gulch

37. Any improvements to the water system will be at the owner's expense, including additional services or fire protection needs.
38. All storm and sewer lines must have separation from water of 10-foot horizontal separation and 1-foot vertical separation below the water main or service line, and service lines which go thru one property to another property must have legal easements granted with documentation submitted to Cal Water before installation.
39. Cal Water's Backflow Specialist must be contacted for a site review to determine what back flow requirements are required and the placement of the assemblies.

The approval of this Grading Permit and any conditions of the approval may be appealed within ten (10) working days of the date of this letter. An appeal form accompanied by the applicable filing fee of \$616.35 must be submitted by **5:00 p.m., on July 2nd, 2021**.

Per County directive due to COVID-19, the Planning and Building Counter is currently closed until further notice. To file an appeal, a completed appeal form shall be emailed to the project planner (contact information below) who will coordinate with the appellant regarding payment of the filing fee. For more information, please contact the project planner, Kanoa Kelley, by email at kkelley@smcgov.org

To provide feedback, please visit the Department's Customer Survey at the following link: <http://planning.smcgov.org/survey>.

FOR STEVE MONOWITZ
COMMUNITY DEVELOPMENT DIRECTOR, By:



Summer Burlison, Senior Planner

cc: Building Inspection Section
Department of Public Works
Geotechnical Section
Drainage Section
Interested Parties



County of San Mateo - Planning and Building Department

ATTACHMENT G

Application for Appeal

County Government Center • 455 County Center, 2nd Floor
Redwood City • CA • 94063 • Mail Drop PLN 122
Phone: 650 • 363 • 4161 Fax: 650 • 363 • 4849

To the Planning Commission

To the Board of Supervisors

Name: Chad Sefcik

Address: 1033 Los Trancos Rd

P.V. Calif

Phone, W: 7076163265 H: _____

Zip: 94028

Permit Numbers involved: _____

Grading Permit PLN2020-00 356

* APPEAL

I have read and understood the attached information regarding appeal process and alternatives.

yes

no

I hereby appeal the decision of the:

Staff or Planning Director

Zoning Hearing Officer

Design Review Committee

Planning Commission

Appellant's Signature: _____

Chad M. Sefcik

Date: 6/28/2021

made on June 28 2021, to approve/deny the above-listed permit applications.

Planning staff will prepare a report based on your appeal. In order to facilitate this, your precise objections are needed. For example: Do you wish the decision reversed? If so, why? Do you object to certain conditions of approval? If so, then which conditions and why?

PLEASE SEE ATTACHED DOCUMENT

Grading Permit PLN2020-00 APPEAL

I appeal the grading permit decision itself. This cut for large footprint of this massive home on this slope has no ideal plan for capturing stormwater runoff and dissipating it. Furthermore, it doesn't acknowledge subsurface groundwater and how grading/building will alter that. This much impervious surface due to size of project on a slope like this is not acceptable. A small drywell will gather all the water from the entire site from downspouts, surface drainage, and underground perforated pipes? Given the elevated amount of rainfall we often receive in the Santa Cruz Mountains during winter storms, the enormous amount of water is likely to overwhelm the 6'x6'x3' pit and quickly saturate the soil. 1033 and 1035 Los Trancos (downhill of project) both have flooding in our basement due to groundwater streaming into our basement when the soil becomes saturated after repeated winter storms. We are concerned that concentrating all of the property's runoff into the rear of the property, near the rear retaining wall, will result in additional hydraulic head and exacerbate the issue we have with basement flooding. None of the plans – tree removal, grading, architecture – show trees located in adjacent properties within several feet or along the property line. There are significant trees near/along the property line where the retaining wall and its pilings, which will be at least 6' deep, are proposed to be placed. The excavation and placement of the retaining wall should not harm these trees that were ignored in the survey used for the plans I don't understand why none of the water is being directed to the street. In addition, 1035's septic drainfield ends about 5' from the property line, just opposite this drywell. Did the engineer use the typical flux of rainfall for a winter storm (or series of storms) in our area of Santa Cruz Mountains to justify size and placement of this seemingly small drywell and whether the percolation rate is sufficient to avoid surface flooding (i.e, whether it can effectively drain). Also, what happens if it plugs? If sewage can be pumped uphill to the street sewer mainline, then so could concentrated runoff be pumped up and directed to the street. The project engineers note that fluctuation of ground water can occur due to variations in rainfall, landscaping, underground drainage patterns. They also mention that perched groundwater could develop in soils near surface of bedrock due to significant rainfall. They also noted they should revise their planned rear drywell, which routes surface water into the ground of this hillside lot-environment, to route stormwater to County storm drain. Last, but not least, engineers expressed large fills are generally not desirable on slopes like this. San Mateo County, itself, has its own concerns within its Geotechnical Department regarding the water issues and the development plan- per County Geotechnical Department notes date 12/30/2020. By granting this grading permit, the county is green lighting the building permit for this massive building -without full regard to the project's downhill neighbors in my opinion. Any revised water runoff plan needs to be reviewed and accepted by engineers.

I have read and understood the attached information regarding appeal process and alternative.

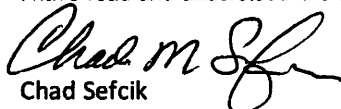

Chad Sefcik
1033 Los Trancos Road
Portola Valley, CA 94028